

ASCON spa
 20021 Bollate (Italy)
 Tel. +39 02 333 371
 Fax +39 02 350 4243
 www.ascon.it
 sales@ascon.it



mod. IO-CB/DO-16TS-00

M.I. IO-CB/IO-DO-16TS-1/04.9
 Cod. J30-658-1ADO-16TS IE

Installation Manual

Contents

- General description
- Accessories
- Installation
- Electrical connections
- Electric safety

CANopen I/O Module

16 Digital Outputs

mod. IO-CB/DO-16TS-00

16 digital outputs

- 16 digital outputs at 24 Vdc, 0.5A, optoisolated with special functions:
- Filter, polarity,
 - Pulse generation.



General description

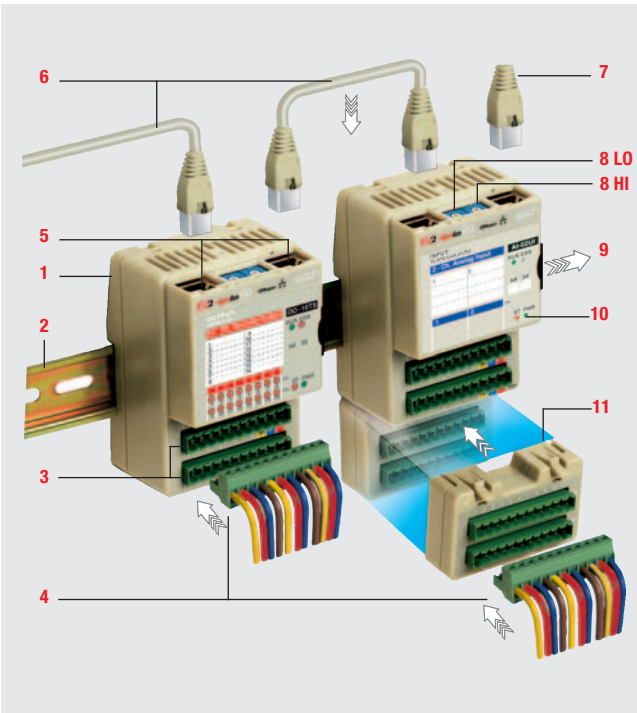

- 1 - Model identification label (on the back side of the module)
- 2 - DIN RAIL 35 x 7.5 (EN50022)
- 3 - 2 male 11 pole plugs, pitch 5.0 mm
- 4 - 2 + 2 female, 11 pole, fast snap-ON connectors, pitch 5.0mm, with screw or spring terminals to connect the power supply or the I/O (accessory)
- 5 - Two RJ45 plugs to connect the field bus
- 6 - Field bus cable with two RJ45 connectors (accessory)
- 7 - RJ45 plugs with internal termination circuitry (accessory)
- 8 - 2 rotary switches having 16 positions to set Node ID and Baud rate
- 9 - Removable and writable label to identify the connected I/O (TAG number)
- 10 - 4 status LEDs: identify the diagnostic and the module status
- 11 - Additional terminal block 2 x 11 poles (accessory)

Installation

Dimensions (mm)

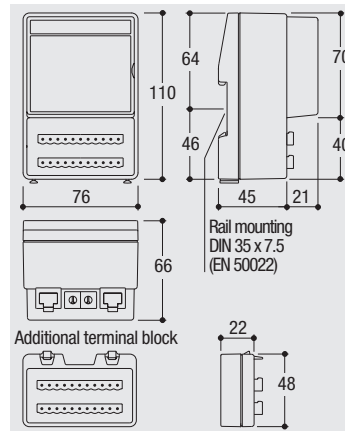

Operating conditions

Environmental condition	Symbol	Suggestion
Operating conditions	Temperature: -10...+65°C Humidity: 5...95% Rh non condensing	
Special conditions	Temperature: > 65°C Humidity: > 95% RH	Use forced ventilation Warm up
Forbidden conditions	Conducting atmosphere Corrosive atmosphere Explosive atmosphere	Use filter

Mounting position

- Mount the module vertically
- In order to help the ventilation flow of air, respect the distances between modules and walls or other modules.

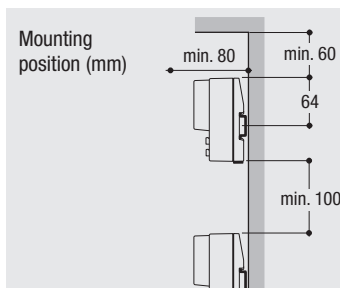

Mounting/removing the modules on/from the DIN rail

- 1 Close the spring slide, then clip the upper part of the module on the rail
- 2 Rotate the module downwards till to the click
- 3 Switch OFF the Power Supply
Lower the spring slide by inserting a flat-blade screwdriver as indicated
- 4 Turn and lift the module upwards.

Mounting the module

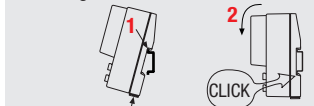

Removing the module

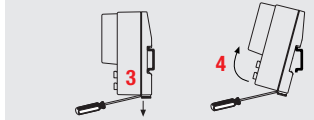

Accessories

Power supply 45W - 2A/24 Vdc
 AP-S2/AL-DR45-24



11 poles connectors
 With screw terminals: AP-S2/SPINA-V11
 With spring terminals: AP-S2/SPINA-M11

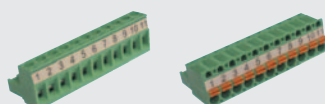

Field bus cables with RJ45 connectors
 140 mm: AP-S2/LOCAL-BUS76
 220 mm: AP-S2/LOCAL-BUS152



Power supply 120W - 5A/24Vdc
 AP-S2/AL-DR120-24

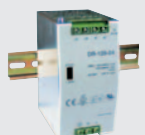

Additional terminal block
 AP-S2/TB-211-1

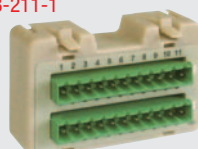

2 connectors with termination circuitry
 AP-S2/TERM-CAN



Hot swapping the modules

Node ID and Baud rate of the new module must already be correctly set.
 The procedure to minimize the CANbus disconnection time follows:

- 1 Remove all the cabled connectors from their plugs (item 4 in "General description" paragraph), do not extract the CANbus RJ45 connectors yet
- 2 Remove the module from the DIN rail
- 3 Mount the new and already configured module on the DIN rail
- 4 Extract the left side RJ45 connector from the module and insert it in the new module
- 5 Extract the right side RJ45 connector from the module and insert it in the new module
- 6 Insert all the cabled connectors in the new module.

Electrical connections

Terminals connections and plugs

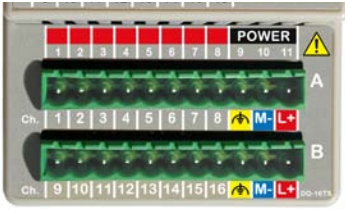

Description	Terminals	CAN Bus
Flexible cable section:	0.2...2.5 mm ² AWG24...AWG12	CAT 5 UTP 8xAWG24
Stripped wire	Screw: 7mm Spring: 10mm	RJ45 mounting tool
Flat blade screwdriver	0.6 x 3.5 mm	
Tightening torque	0.5...0.6 Nm	

Technical data:

- Two 11 poles plugs, pitch 5.0 mm
- Made with self extinguishing material as required by UL94 V0 standard
- Overvoltage category/pollution degree II/2
- Max. load current/section 8A/2.5mm² at 65°C
- Pulse test voltage: 800 Vp.

Source Type (PNP) Digital Output

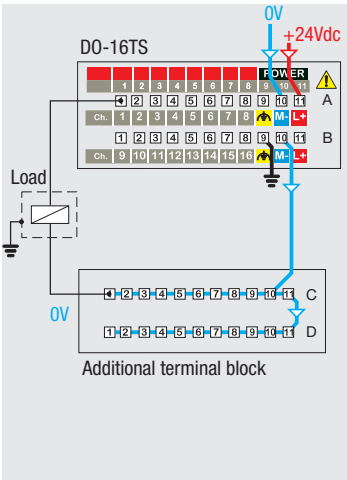

24 Vdc, 0.5A digital outputs

- Respect the polarity
- When present the shield must be connected to a proper earth (at only one end).

Power supply

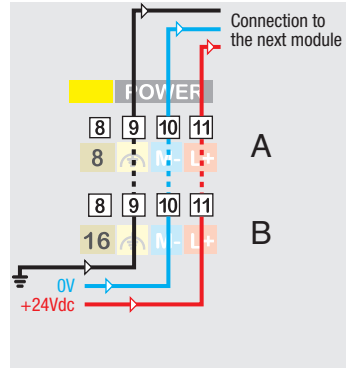

- 24Vdc (-15...+25%), 3W max.
- The power supply terminals A9 - B9, A10 - B10, A11 - B11 are internally connected; in this way it is possible to bring the power supply to other modules using terminals A10, A11 and B10, B11.

Functional earth terminal. This type of earthing does not protect against electrical shocks.

Power Supply Warnings

- Please note that the maximum current capacity for each terminal is 8A
- Make sure that the overall current absorption (modules and field devices) matches the power supply
- In order to avoid excessive voltage drops, install the most power consuming modules closer to the power supply.

Additional terminal block TB-211-1

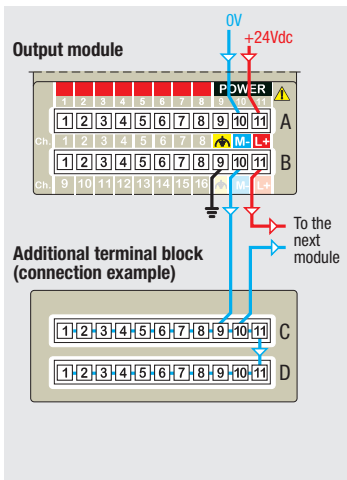

An additional terminal block can be installed on the I/O module using the two slides located in the lower part of the module case (item 11 in "General description" paragraph).

The additional terminal block has no active components inside, only two 11 contacts connectors.

All the 11 contacts of each connector (C and D) are internally connected and can be used to make multiple connections (see the example).

CAN bus connection

- 1 Install the modules on the DIN rail (max. 60, up 127 with repeaters)
- 2 Connect the modules mounted side by side using the standard cables (140/220mm)
- 3 Connect the remote modules using a cable with the proper length (see table)
- 4 Terminate the two ends of the CAN bus network using the connectors with the termination circuitry.

Maximum length of the field bus network:

Meters	Baud rate
2500	20 kbps
1000	50 kbps
500	125 kbps
250	250 kbps
100	500 kbps
50	800 kbps
25	1000 kbps

CAN bus signals

The signals present in the two RJ45 connectors are connected in parallel in order to link all the modules to the CAN bus.

Pin	Signal
1	CANH
2	CANL
3	GNDCAN
4	Reserved
5	Reserved
6	GNDSHLD (1)
7	GNDCAN
8	CANV+

(1) Shield to protect the communication cables (suggested when the bus network is longer than 100m).

CE Electric safety and electromagnetic compatibility

Classe II instrument, rear panel mounting. This instrument has been designed in compliance with:

Regulations on electrical equipment: according to regulations on the essential protection requirements in electrical equipment EN 61010-1

Regulations on Electromagnetic Compatibility according to:

- Regulations on RF emissions: EN61000-6-4 industrial environments;
- Regulation on RF immunity: EN61000-6-2 industrial equipment and system.

It is important to understand that it's responsibility of the installer to ensure the compliance of the regulations on safety requirements and EMC.

This controller has no user serviceable parts and requires special equipments and specialised engineers to be repaired. For this purpose, the manufacturer provides technical assistance and the repair service for its Customers. Please, contact your nearest Agent for further information.

All the information and warnings about safety and electromagnetic compatibility are marked with the sign, at the side of the note.

Before installing the module read the following instructions

Precautions



- All wirings must comply with the local regulations
- The supply wiring should be routed away from the power cables
 - Avoid to use electromagnetic contactors, power relays and high power motors nearby
 - Avoid power units nearby, especially if controlled in phase angle
 - Keep the low level sensor input wires away from the power lines and the output cables. If this is not achievable, use shielded cables on the sensor input, with the shield connected to earth.

Notes

- 1 Make sure that the power supply voltage is the same indicated on the instrument label
- 2 Switch ON the power supply only after all the electrical connections have been completed