

**ASCON spa**  
 20021 Baranzate (Italy)  
 Fax +39 02 350 4243  
 www.ascon.it  
 sales@ascon.it



## mod. IO-CB

M.I. IOD-CB-2/10.06  
 Cod. J30-658-1AIOD-CB E

# Installation Manual

### Contents

- General description
- Accessories
- Installation
- Electrical connections
- Electric safety

## CANopen Digital I/O Modules



- IO-CB/DI-16LV:** 16 Isolated Digital Inputs
- IO-CB/DI-16HV:** 16 Isolated Digital Inputs 120Vac
- IO-CB/DI-32LV:** 32 Isolated Digital Inputs
- IO-CB/DM-08TS:** 8 Digital Programmable Inputs/Outputs
- IO-CB/DM-16TS:** 16 Digital Programmable Inputs/Outputs
- IO-CB/DM-32TS:** 32 Digital Programmable Inputs/Outputs
- IO-CB/DO-04RL:** 4 Relay Digital Outputs
- IO-CB/DO-08RL:** 8 Relay Digital Outputs
- IO-CB/DO-04TX:** 4 High Power Digital Outputs
- IO-CB/DO-08TS:** 8 Isolated Digital Outputs
- IO-CB/DO-16TS:** 16 Isolated Digital Outputs
- IO-CB/DO-32TS:** 32 Isolated Digital Outputs
- IO-CB/DO-32TR:** 32 Digital Outputs

### General description

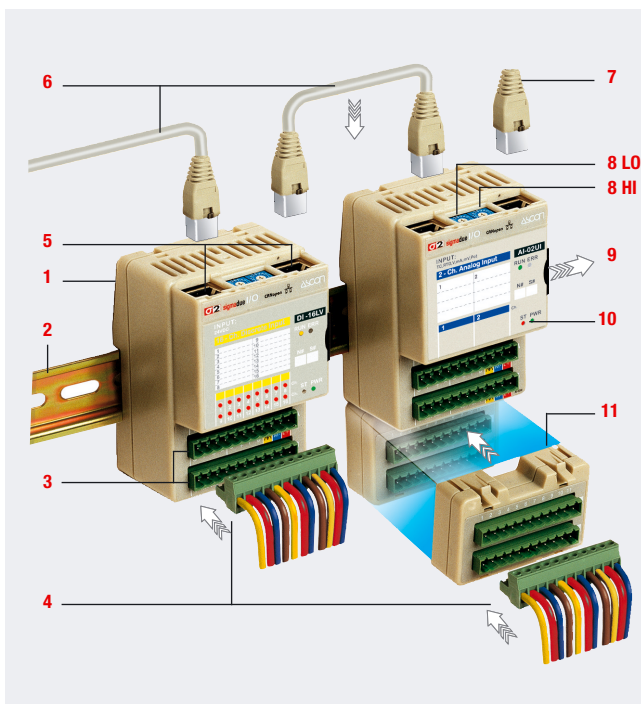

- 1 - Model identification label (on the back side of the module)
- 2 - DIN RAIL 35 x 7.5 (EN50022)
- 3 - 2 male 11 pole plugs, pitch 5.0mm
- 4 - 2 + 2 female, 11 pole, fast snap-ON connectors, pitch 5.0mm, with screw or spring terminals to connect the power supply or the I/O (accessory)
- 5 - Two RJ45 plugs to connect the fieldbus
- 6 - CANopen cable with two RJ45 connectors (accessory)
- 7 - RJ45 plugs with internal termination circuitry (accessory)
- 8 - 2 rotary switches having 16 positions to set Node ID and Baud rate
- 9 - Removable and writable label to identify the connected I/O (TAG number)
- 10 - 4 status LEDs: identify the diagnostic and the module status
- 11 - Additional terminal block 2 x 11 poles (accessory)

### Installation

#### Dimensions (mm)

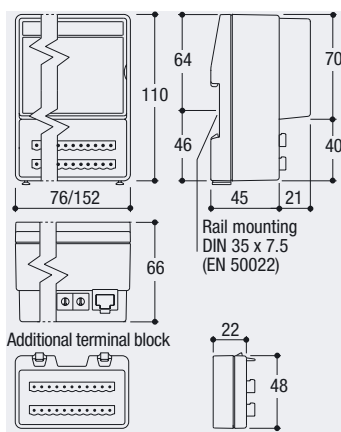

#### Operating conditions

Environmental condition	Symbol	Suggestion
Operating conditions	Temperature -10...+65°C	
	Humidity 5...95% Rh non condensing	
Special conditions	Temperature > 65°C	Use forced ventilation
	Humidity > 95% RH	Warm up
Forbidden conditions	Conducting atmosphere	Use filter
	Corrosive atmosphere	
	Explosive atmosphere	

#### Mounting position

- Mount the module vertically
- In order to help the ventilation flow of air, respect the distances between modules and walls or other modules.

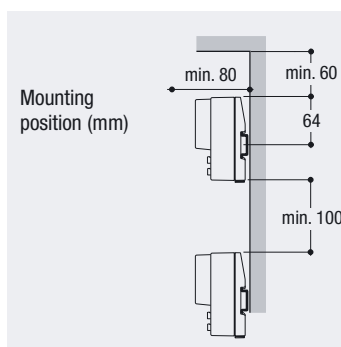

#### Mounting/removing the modules on/from the DIN rail

- 1 Close the spring slide, then clip the upper part of the module on the rail
- 2 Rotate the module downwards till to the click
- 3 Switch OFF the Power Supply  
Lower the spring slide by inserting a flat-blade screwdriver as indicated
- 4 Turn and lift the module upwards.

#### Mounting the module

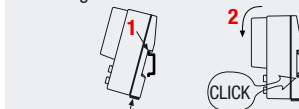

#### Removing the module



### Accessories

Power supply 45W - 2A/24 Vdc  
**AP-S2/AL-DR45-24**



11 poles connectors  
 With screw terminals: **AP-S2/SPINA-V11**  
 With spring terminals: **AP-S2/SPINA-M11**

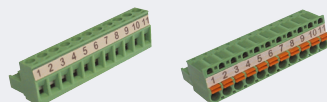

Field bus cables with RJ45 connectors  
 140 mm: **AP-S2/LOCAL-BUS76**  
 220 mm: **AP-S2/LOCAL-BUS152**



Power supply 120W - 5A/24Vdc  
**AP-S2/AL-DR120-24**



Additional terminal block  
**AP-S2/TB-211-1**

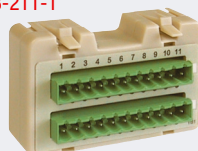

2 connectors with termination circuitry  
**AP-S2/TERM-CAN**



### Hot swapping the modules

**Node ID and Baud rate of the new module must already be correctly set.**

The procedure to minimize the CAN disconnection time follows:

- 1 Remove all the cabled connectors from their plugs (item 4 in "General description" paragraph), do not extract the CAN RJ45 connectors yet;
- 2 Remove the module from the DIN rail;
- 3 Mount the new and already configured module on the DIN rail;
- 4 Extract the left side RJ45 connector from the module and insert it in the new module;
- 5 Extract the right side RJ45 connector from the module and insert it in the new module;
- 6 Insert all the cabled connectors in the new module.

# Electrical connections

## Terminals connections and plugs

DI-16LV

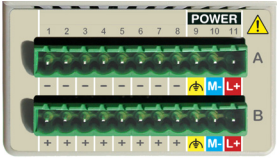

DO-04TX

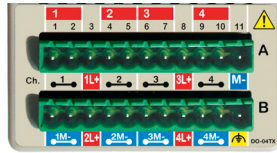

DM-32TS

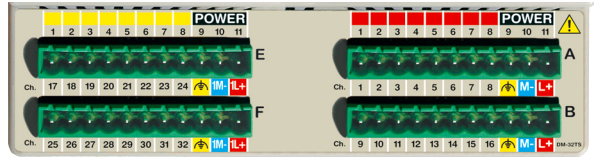

DI-16HV

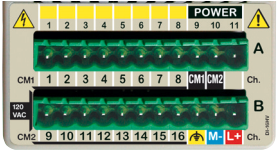

DO-32TR

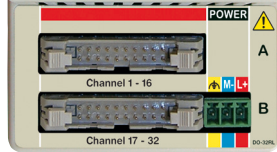

Description	Terminals	CANopen
Flexible cable section:	0.2...2.5 mm <sup>2</sup> AWG24... AWG12	CAT 5 UTP, 8 x AWG24
Stripped wire	Screw: 7mm; Spring: 10mm	RJ45 mounting tool
Flat blade screwdriver	0.6 x 3.5 mm	
Tightening torque	0.5...0.6 Nm	

- Technical data:
- Two/Four 11 poles plugs, pitch 5.0 mm
  - Made with self extinguishing material as required by UL94 V0 standard
  - Overvoltage category/pollution degree II/2
  - Max. load current/section 8A/2.5mm<sup>2</sup> at 65°C
  - Test pulse voltage: 4 kVp.

### Power supply (except DO-04TX and DO-32TR)

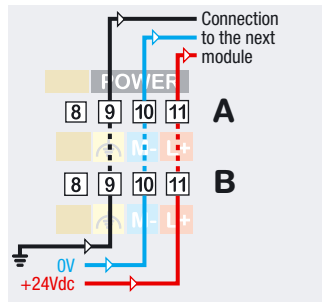

- 24Vdc (-15...+25%), 2.5W max.
- The power supply terminals A9 - B9, A10 - B10, A11 - B11 are internally connected; in this way it is possible to bring the power supply to other modules using terminals A10, A11 and B10, B11.

Functional earth terminal. This type of earthing does not protect against electrical shocks.

### Additional terminal block TB-211-1

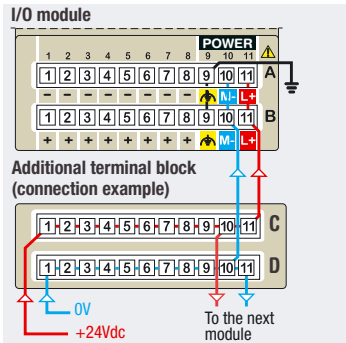

An additional terminal block can be installed on the I/O module using the two slides located in the lower part of the module case (item 11 in "General description" paragraph).

The additional terminal block has no active components inside, only two 11 contacts connectors.

All the 11 contacts of each connector (C and D) are internally connected and can be used to make multiple connections (see the example).

### Power supply warnings

- Please note that the maximum current capacity for each terminal is 8A
- Make sure that the overall current absorption (modules and field devices) matches the power supply
- In order to avoid excessive voltage drops, install the most power consuming modules closer to the power supply.

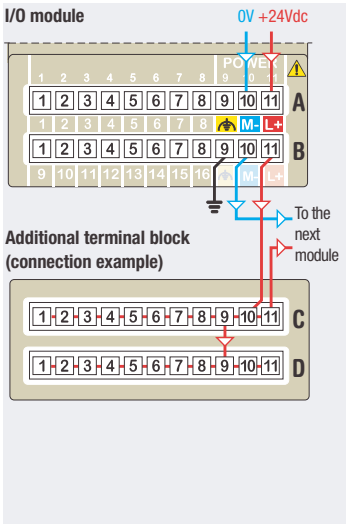

Terminals of connectors C and D are connected to +24Vdc in order to power the I/O external devices

### Power supply (DO-04TX)

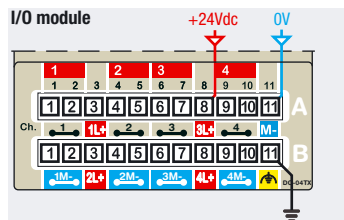

- 24Vdc (-15...+25%), 3W max. The module is powered by the terminals A8 (3L+ = +24Vdc) and A11 (M- = 0Vdc).
- The power supply terminals of the channels, A3 (1L+), A8 (3L+), B3 (2L+), B8 (4L+), are not internally connected as each output channel may switch up to 6 A.
- For the correct functioning of the loads, connect each load to its proper 0V: terminals 1M- for channel 1, 2M- for channel 2, 3M- for channel 3, 4M- for channel 4.

Functional earth terminal. This type of earthing does not protect against electrical shocks.

DO-04TX I/O module

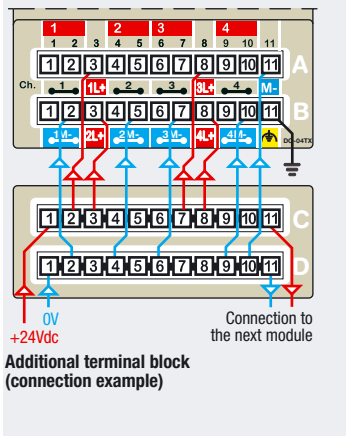

Terminals of connectors C and D are connected to +24Vdc in order to power the different sections of the DO-04TX I/O module

### Power supply (DO-32TR)

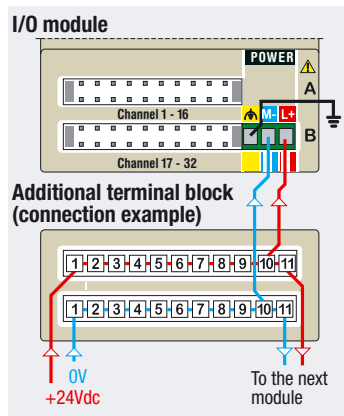

- The DO-32TR module has 3 distinct connectors; 2 of them are used to connect the external relay modules. Each module has 16 distinct relay output channels.
- The third connector powers the module.

Functional earth terminal. This type of earthing does not protect against electrical shocks.

### Digital Inputs Type II (EN6131-2)

#### Contact input

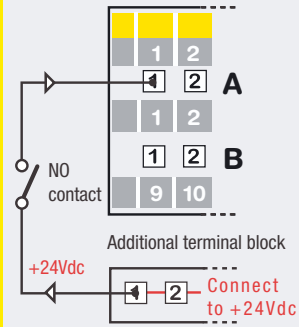

- Respect the polarity;
- When present the shield must be connected to a proper earth (at only one end).

## DI-xxLV

#### Source (PNP) device

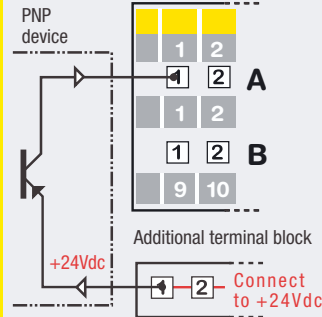

- Respect the polarity.
- When present the shield must be connected to a proper earth (at only one end);
- If the input device needs to be powered by the module, verify that the current consumption does not exceed the power supply limits.

### Digital Inputs Type II (EN6131-2)

#### NO contact and Source (PNP) output devices

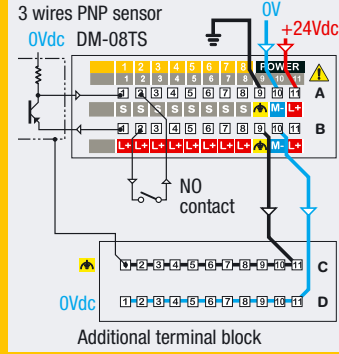

- 24 Vdc inputs,
- Respect the polarity;
  - When present the shield must be connected to a proper earth at one end using, for example, the additional terminal block TB-211-1;
  - Inputs 1 and 2 can be set to enable the following functions:
    - pulse counting measurements;
    - pulse frequency measurements;
    - pulse width measurements.

## DM-xxTS

### Digital Outputs

#### Source (PNP) digital output 24Vdc 0.5A

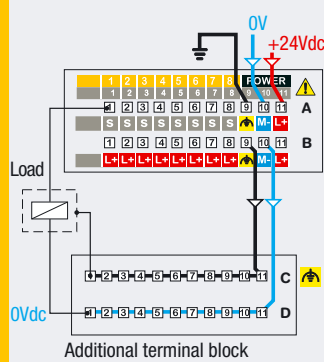

- Each of 8 channels can be set through the MODBUS as either input or output
- Output 3 and 4 can be configured as PWM (Pulse Width Modulation) output or pulse output
- In order to protect the output circuits, clamp diodes are installed in the module. However, when high inductive loads are to be switched or when more loads are to be switched at the same time, external damping circuits should be provided.

### ⚠ 120Vac Digital Inputs 1...16 Type II (EN61131-2)

#### 120VAC inputs

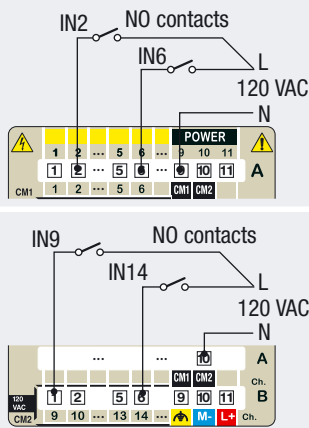

- ⚠ DANGER**  
High voltage inputs, pay extreme attention to these input connections.
- ⚠** Terminal A9 (CM1) is the common (neutral) terminal of the 120Vac digital inputs 1...8 (at terminals A1...A8); terminal A10 (CM2) is the common (neutral) terminal of the 120Vac digital inputs 9...16 (at terminals B1...B8).
- ⚠** Respect the polarity shown, each common terminal is shared by 8 digital inputs.

## DI-16HV

### Relay Digital Output

DO-04RL

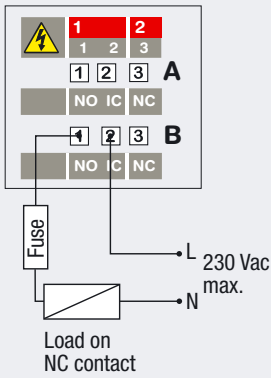

- Protect loads with fast type fuses
- For Solid State Relays models, the max. ac current that can flow in the SSR is 1A at 25°C. For higher ambient temperatures derate linearly to 0.5A at 65°C
- Contact terminals A1-B1... A8-B8 are internally connected. This would be useful for multiple loads.

# DO-xxRL

### Source Type (PNP) Digital Output

DO-16TS

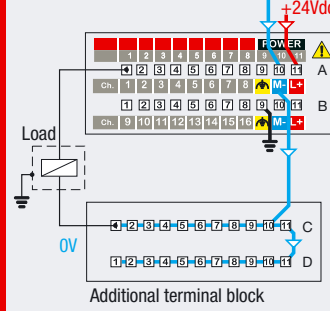

- 24 Vdc, 0.5A digital outputs
- Respect the polarity
- When present the shield must be connected to a proper earth (at only one end).

# DO-xxTS

### Output modules with external relay block

DO-32TR

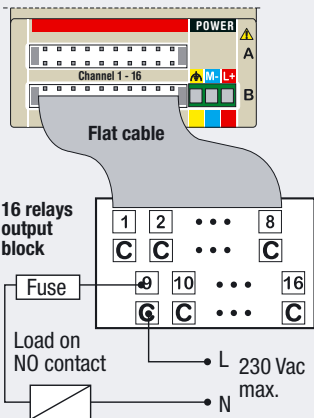

- Protect loads with fast type fuses
- The max. length of the flat cables is 750 mm.

# DO-32TR

### 6A Digital Outputs

DO-04TX

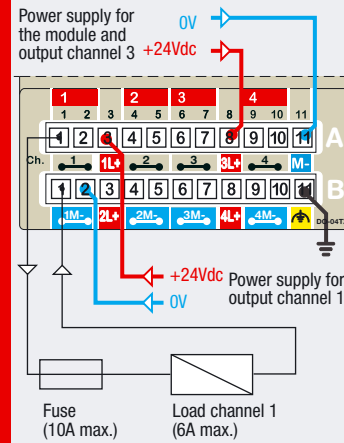

- Respect the polarity.
- When present the shield must be connected to a proper earth (at only one end);
- Protect loads with fast type fuses adequate to the power consumption of each load (10A max.)

# DO-04TX

### CAN connection

- 1 Install the modules on the DIN rail (max. 60, up to 127 with repeaters)
- 2 Connect the modules mounted side by side using the standard cables (140/220mm)
- 3 Connect the remote modules using a cable with the proper length (see table)
- 4 Terminate the two ends of the CAN network using the connectors with the termination circuitry.

Maximum length of the fieldbus network:

Meters	Baud rate
2500	20 kbps
1000	50 kbps
500	125 kbps
250	250 kbps
100	500 kbps
50	800 kbps
25	1000 kbps

### CAN signals

The signals present in the two RJ45 connectors are connected in parallel in order to link all the modules to the CAN.

Pin	Signal
1	CANH
2	CANL
3	GNDCAN
4	Reserved
5	Reserved
6	GNDSHLD (1)
7	GNDCAN
8	CANV+

(1) Shield to protect the communication cables (suggested when the bus network is longer than 100m).

## Electric safety and electromagnetic compatibility

**Class II instrument, rear panel mounting.**  
This instrument has been designed in compliance with:

**Regulations on electrical equipment:**  
according to regulations on the essential protection requirements in electrical equipment EN 61010-1

**Regulations on Electromagnetic Compatibility** according to:  
- Regulations on RF emissions:  
EN61000-6-4 industrial environments;  
- Regulation on RF immunity:  
EN61000-6-2 industrial equipment and system.

It is important to understand that it's responsibility of the installer to ensure the compliance of the regulations on safety requirements and EMC.

This controller has no user serviceable parts and requires special equipments and specialised engineers to be repaired. For this purpose, the manufacturer provides technical assistance and the repair service for its Customers. Please, contact your nearest Agent for further information.

All the information and warnings about safety and electromagnetic compatibility are marked with the sign, at the side of the note.

### Before installing the module read the following instructions

#### Precautions



- All wirings must comply with the local regulations
- The supply wiring should be routed away from the power cables
  - Avoid to use electromagnetic contactors, power relays and high power motors nearby
  - Avoid power units nearby, especially if controlled in phase angle
  - Keep the low level sensor input wires away from the power lines and the output cables. If this is not achievable, use shielded cables on the sensor input, with the shield connected to earth.

#### Notes

- 1 Make sure that the power supply voltage is the same indicated on the instrument label
- 2 Switch ON the power supply only after all the electrical connections have been completed