

ISO9001 Certified

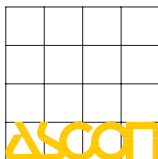

ASCON spa
20021 Baranzate (Italy)
Fax +39 02 350 4243
www.ascon.it
sales@ascon.it



mod. **IO-CB/DI-16HV-00**

M.U. IO-CB/DI-16HV-0/10.06
Cod. J30-658-1ADI-16HV E

User manual

Contents

- Characteristics
- Functional Block Diagram
- PDOs used by the module
- Hardware Set-up
- Parameter configuration
- Commands
- Emergency messages
- Parameter Store/Restore
- Object Dictionary

APPLICABLE STANDARDS

The DI-16HV module is suited for the CiA DS301 protocol [1] and implements the CiA DS401 standard Device Profile [2].

Characteristics

Technical data

Number of channels	16
Polarity	Sink (PNP)
UL (state 0)	0... 70 Vac
UT (transition)	70... 85 Vac
UH (state 1)	85... 140 Vac
Input impedance	33 kΩ
ON/OFF delay	20 ms
Max. monostable time	65 s

General

3 way isolation	Channel to Channel	No
	Channel to Logic	2500 Vp
	Logic to Serial Bus	800 Vp
	Power Supply to Logic	800 Vp
Power supply	24 Vdc; -15...+25%	
Power consumption	3 W	
Overvoltage protection	40 Vdc	
Dimensions	L: 76; H: 110; W: 65	
Weight	220 g	
Safety regulations	Isolation class II (50Vrms)	
EN61010-1	Installation category II	
	Pollution degree 2	
CE marking	EN61131-2	

3 way isolation diagram

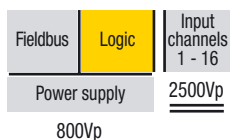

Environment

	Operating	Storage
Temperature	-10...+65°C	-40...+85°C
Relative Humidity	5...95% non condensing Appropriate measures must be taken against humidity >85%	5...95% non condensing For a short period, slight condensation may appear on the housing
Mounting	Vertical, free air	
Protection	IP20	
Vibrations (3 axes)	10...57Hz 0.0375mm 57...150Hz 0.5g	
Shock (3 axes)	15g, 11ms half sine	

CANopen I/O module 16 Isolated Digital Inputs 120 Vac mod. **IO-CB/DI-16HV**



16 optoisolated digital inputs with special functions

- Latched inputs;
- Monostable inputs;
- Edge detect and interrupt.



- 1) The product described in this manual should only be installed, operated and maintained by qualified application programmers and software engineers who are familiar with automation safety concepts and applicable national standards.
- 2) This product supports the Parameter defaults indicated by CiA standards, in addition, some parameters have a factory set (value present in the module when comes from the factory). The default values can be loaded with the restore command, but after the restore, factory set values are lost.

Functional Block Diagram

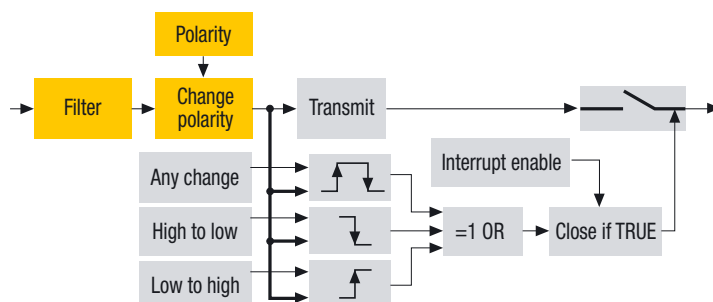

PDOs used by the module

TPDO	Properties	Mapped objects	Index	Sub-index
TPDO 1	COBID: 180h+ NodeID Transmission Type: 01h *	Read digital input (1-8)	6000h	01h
		Read digital input (9-16)	6000h	02h
TPDO 2	COBID: 280h+ NodeID Transmission Type: 01h *	Read Input Latch 1-8	2011h	01h
		Read Input Latch 9-16	2011h	02h
		Read Input Wait 1-8	2012h	01h
		Read Input Wait 9-16	2012h	02h

Note: * The Transmission Type is configurable:

01h is the factory set (value present in the modules when come from the factory);
FFh is the default value

Hardware Set-up

Hexadecimal rotary switches, service and I/O LEDs

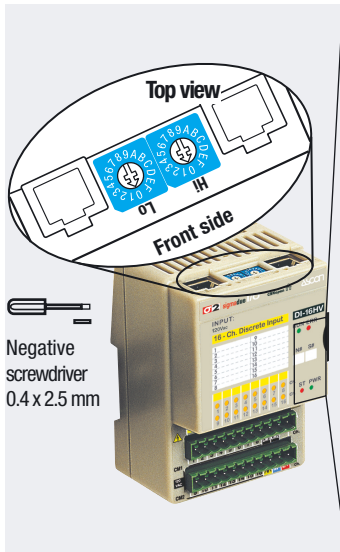

Service LEDs	Status	Meaning
	ON	Operational
RUN	Blinking	Pre-operational (CANopen)
●	Single flash	STOPPED
	OFF	Device in RESET state
	ON	BUS OFF
ERR	Single flash	Warning limit reached
●	Double flash	Error Control Event
	Triple flash	Sync Error (CANopen)
	OFF	No error. Device working
ST	ON	DIAG Error
●	Blinking	INIT and DIAG running
	Single flash	Baud rate setting
	OFF	Module OK and ready
PWR	ON	Module Power Supply ON
●	OFF	Module Power Supply OFF

I/O LEDs	Status	Meaning
IN 1...16	ON	Input active
●	OFF	Input inactive

Bit Rate and Node ID configuration

Bit rate

Lo switch	Baud rate kbps	Bus length m
1	20	2500
2	50	1000
3	100	500
4	125	500
5	250	250
6 *	500	100
7	800	50
8	1000	25

Node ID

Hi switch	Lo switch	Valid ID Node
0	1	01h (address 1)
0	2	02h (address 2)
↓	↓	↓
7	F	7Fh (address 127D) *

Notes: * Default value

Procedure for Node ID and Bit Rate configuration

The HI and LO hexadecimal rotary switches set the module's Bit Rate and CAN Node ID. During the configuration, the module must be **off line** and the CAN bus must be physically disconnected.

To configure the module, follow the procedure:

- 1 Turn the Power OFF
- 2 Set the HI switch to "F"
- 3 Select the desired Bit Rate value by setting the LO switch following the table (e.g. "8" for 1 Mbps)
- 4 Turn the Power ON
- 5 Shift the HI switch to "E" (all the module service LEDs should flash)
- 6 Turn the Power OFF. Now configure Node ID
- 7 Set the HI and LO switches to the desired valid Node ID following the table
- 8 Turn the Power ON.

Alternatively, at step 7 set the value 00h. Then, at the next Power ON, the last valid stored value will be resumed as Node ID.

Default values: Bit Rate = 500 kbps, Node ID = 127D

Parameter configuration

Configuring the Input Channels

The functional block diagram for the Inputs is consistent with the standard profile CiA DS401 [2].

The digital signal is first filtered (**Index 6003h – Filter Constant Input 8-bit and Index 2004 - Filter Constant**), then polarised (**Index 6002 – Polarity Input 8-bit**) and finally assigned to the variable that contains its value (**Index 6000h – Read Input 8-bit**). The information is now ready to be transmitted on the CAN network via the TPDO1.

Other entries determine the trigger condition:

Index 6006h – Interrupt Mask Any Change 8-bit:

detection of any input level change.

Index 6007h – Interrupt Mask Low-to-High 8-bit:

detection of a Low-to-High edge.

Index 6008h – Interrupt Mask High-to-Low 8-bit

detection of a High-to-Low edge

Index 6005h – Global Interrupt Enable

the actual PDO transmission is performed if two initial conditions are met: the variable in Index 6005h should be "TRUE" and the PDO transmission type should be 255.

In addition to the expected functions, the module provides a number of proprietary input function options. Below is an explanation of the added functions.

• Input Latch: Available for all inputs

Index 2011h – Read Input Latch contains the value of the staticised inputs.

Index 200Eh – Reset Latch commands the resetting of a single latched input on a bit basis: writing 1 to the n-th bit resets the n-th input channel. The latching function acts after the filtering and polarity settings.

• Input monostable: Available for all inputs

The input active value is maintained for a duration of time configurable with the

Index 2010h – Time Value (16 element ARRAY, time base 5ms). The state of the inputs are kept in

Index 2012h – Read Input Wait.

Module specific parameters

Index 3000h – Node Address

Current Module Node ID.

Index 3001h – Baudrate

Current Module Bit rate

Commands

Index 200Ch – Operating mode

The device has its own internal state machine. It is possible to move through this by sending appropriate values to the Index 200Ch, following the table below.

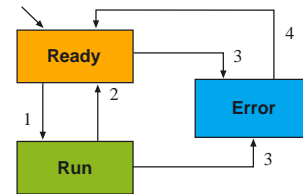

Transition	Operating mode value	Behaviour
Init	-	At Power-Up, the Device is in the "ready" state. Transition 1 is also executed if Index 200Ch. Operating Mode contains the default value 1
1	01h	Operating mode "RUN" is activated
2	00h	Return to the initialisation "ready" state. The transition is performed: <ul style="list-style-type: none"> • following an operator's command • after assigning a configuration parameter (2004h, 2010h)
3	FFh	The "error" state is automatically assigned by the device (and the operating mode value is read only) when: <ul style="list-style-type: none"> • an attempt is made to execute an unexpected command
4	00h	This value causes an exit from the "error" state, after the error condition is acknowledged. The only transition is to the "ready" state

Emergency messages

The module automatically sends emergency messages including error codes. The communication errors are described in CiA DS301 [1]. The error codes are expressed as a DEVICE SPECIFIC ERROR type of code. The codes indicating a specific condition are also inserted, following the table below:

Error code	Error
000000000	No error – This code is generated when exiting an error condition, to notify the end of one of the error states
000000007	Error Wrong Command – An attempt to execute a command from an illegal state

Emergency Message	0 01h	1 FFh	2 21h	3 00h	4 00h	5 00h	6 00h	7 0yh
	COB – ID = [entry 1014h] + NodeID							
	Error code							

Parameter Store/Restore

This module allows parameters to be saved in a non volatile memory. In order to avoid storing parameters by mistake, storage is only executed when a specific signature is written to the appropriate subindex. The signature is “save”.

Similarly, the default values of parameters, according to the communication or device profile, are restored. On receipt of the correct signature in the appropriate subindex, the device restores the default parameters and then confirms the SDO transmission. The signature is “load”.

The new configuration becomes active after a reset, i.e. after a “Power OFF/Power ON cycle” or an NMT “Reset Node” message.

Byte	0	1	2	3	4	5	6	7
Store Parameter	22h	10h	10h	01h	73h	61h	76h	65h
	COB – ID = 600h + NodeID							
Restore Parameter	22h	11h	10h	01h	6Ch	6Fh	61h	64h
	COB – ID = 600h + NodeID							

SDO Messages

The entries of a device Object Dictionary are accessed through SDO (Service Data Object) messages. The basic SDO messages are as follows, as based on the Client – Server request and response model:

Byte	0	1	2	3	4	5	6	7
Read request	40h	Index		Sub-Index	Reserved			
	COB – ID = 600h + NodeID							
Read response	4XFh	Index		Sub-Index	Data			
	COB – ID = 580h + NodeID							
Write request	22h	Index		Sub-Index	Data			
	COB – ID = 600h + NodeID							
Write response	60h	Index		Sub-Index	Reserved			
	COB – ID = 580h + NodeID							

* This code is type dependant.

Please refer to the CiA DS301 Profile for more details.

Reference documents

List of CiA documents to which the user should refer:

- [1] CiA DS301 - CANopen Application Layer and Communication Profile;
- [2] CiA DS401 - CANopen Device Profile for generic I/O Modules.

Accessories, Spare Parts and Warranty

Power Supply 45W 24Vdc 2A	AP-S2/AL-DR45-24
Power Supply 120W 24Vdc 5A	AP-S2/AL-DR120-24
Additional Terminal Block 2x11	AP-S2/TB-211-1
Female Plug 11 Screw clamp	AP-S2/SPINA-V11
Female Plug 11 Spring clamp	AP-S2/SPINA-M11
RJ45 terminated cable 14cm	AP-S2/LOCAL-BUS76
RJ45 terminated cable 22cm	AP-S2/LOCAL-BUS152
CAN termination Adapter	AP-S2/TERM-CAN

Warranty: 3 years excluding defects due to improper use

Object Dictionary (with default values)

In order to configure the module, it is necessary to connect it to a PC with the CAN interface and the supervisory software installed. The configuration can be obtained by writing the desired values to the module's variables listed in the Object Dictionary.

Object Dictionary structure

Index (hex)	Sub Index	Object	Name	Default [hex]	Type	Acc. Attr.	MO
1000		VAR	Device Type	00010194	UNSIGNED32	RO	M
1001		VAR	Error Register	00	UNSIGNED8	RO	M
1003		ARRAY	Predefined error field	00000000	UNSIGNED32	RO	0
1005		VAR	COB-ID SYNC	00000080	UNSIGNED32	RW	0
1006		VAR	Communication cycle period	00000000	UNSIGNED32	RW	0
1007		VAR	Synchronous window length	00000000	UNSIGNED32	RW	0
1008		VAR	Manufacturer Device Name	"16HV"	Vis-String	const	0
1009		VAR	Manufacturer Hardware Version	"1.00"	Vis-String	const	0
100A		VAR	Manufacturer Software Version	"1.00"	Vis-String	const	0
100C		VAR	Guard Time	0000	UNSIGNED16	RW	0
100D		VAR	Life Time Factor	00	UNSIGNED8	RW	0
1010		ARRAY	Store parameters		UNSIGNED32		0
	00h	VAR	Largest subindex supported	01	UNSIGNED8	RO	
	01h	VAR	Save all parameters	03	UNSIGNED32	RW	
1011		ARRAY	Restore default parameters		UNSIGNED32	RW	0
	00h	VAR	Largest subindex supported	01	UNSIGNED8	RO	
	01h	VAR	Restore all default parameters	01	UNSIGNED32	RW	
1014		VAR	COB-ID EMCY	80+NodeID	UNSIGNED32	RW	0
1015		VAR	Inhibit Time EMCY	0000	UNSIGNED16	RW	0
1017		VAR	Producer heartbeat time	0000	UNSIGNED16	RW	0
1018		RECORD	Identity Object		Identity (23h)		0
	00h	VAR	Number of entries	04	UNSIGNED8	RO	
	01h	VAR	Vendor ID	000000E9	UNSIGNED32	RO	
1200		RECORD	Server SDO Param				
	00h	VAR	Number of entries	02	UNSIGNED8	RO	0
	01h	VAR	COB-ID Client -> Server	600+NodeID	UNSIGNED32	RO	
	02h	VAR	COB-ID Server -> Client	580+NodeID	UNSIGNED32	RO	
1800		RECORD	1 st Transmit PDO Comm Param.		PDO CommPar (20h)		M
	00h	VAR	Largest subindex supported	05	UNSIGNED8	RO	
	01h	VAR	COB-ID used	180+NodeID	UNSIGNED32	RW	
	02h	VAR	Transmission type	FF *	UNSIGNED8	RW	
	03h	VAR	Inhibit time	0000	UNSIGNED16	RW	
	04h	VAR	Reseved		UNSIGNED8	RW	
	05h	VAR	Event timer	0000	UNSIGNED16	RW	
1801		RECORD	2 nd Transmit PDO Comm Param.		PDO CommPar (20h)		M
	00h	VAR	Largest subindex supported	05	UNSIGNED8	RO	
	01h	VAR	COB-ID used	280+NodeID	UNSIGNED32	RW	
	02h	VAR	Transmission type	FF *	UNSIGNED8	RW	
	03h	VAR	Inhibit time	0000	UNSIGNED16	RW	
	04h	VAR	Reseved		UNSIGNED8	RW	
	05h	VAR	Event timer	0000	UNSIGNED16	RW	
1A00		RECORD	1 st Transmit PDO Mapping		PDO Mapping (21h)		M
	00h	VAR	No. of mapped application obj.	02	UNSIGNED8	RO	
	01h	VAR	DigInput8_1	60000108	UNSIGNED32	RO	
	02h	VAR	DigInput8_2	60000208	UNSIGNED32	RO	
1A01		RECORD	2 nd Transmit PDO Mapping		PDO Mapping (21h)		M
	00h	VAR	No. of mapped application obj.	04	UNSIGNED8	RO	
	01h	VAR	Read Input Latch 1 – 8	20110108	UNSIGNED32	RO	
	02h	VAR	Read Input Latch 9 – 16	20110208	UNSIGNED32	RO	
	03h	VAR	Read Input Wait 1 – 8	20120108	UNSIGNED32	RO	
	04h	VAR	Read Input Wait 9 – 16	20120208	UNSIGNED32	RO	
2004		ARRAY	Filter Constant		UNSIGNED8		0
	00h	VAR	Number of entries	10	UNSIGNED8	RO	
	01h	VAR	Filter Constant 1	00	UNSIGNED8	RW	
	02h	VAR	Filter Constant 2	00	UNSIGNED8	RW	
	03h	VAR	Filter Constant 3	00	UNSIGNED8	RW	
	04h	VAR	Filter Constant 4	00	UNSIGNED8	RW	
	05h	VAR	Filter Constant 5	00	UNSIGNED8	RW	
	06h	VAR	Filter Constant 6	00	UNSIGNED8	RW	
	07h	VAR	Filter Constant 7	00	UNSIGNED8	RW	
	08h	VAR	Filter Constant 8	00	UNSIGNED8	RW	
	09h	VAR	Filter Constant 9	00	UNSIGNED8	RW	
	0Ah	VAR	Filter Constant 10	00	UNSIGNED8	RW	
	0Bh	VAR	Filter Constant 11	00	UNSIGNED8	RW	
	0Ch	VAR	Filter Constant 12	00	UNSIGNED8	RW	
	0Dh	VAR	Filter Constant 13	00	UNSIGNED8	RW	
	0Eh	VAR	Filter Constant 14	00	UNSIGNED8	RW	
	0Fh	VAR	Filter Constant 15	00	UNSIGNED8	RW	
	10h	VAR	Filter Constant 16	00	UNSIGNED8	RW	
200C		VAR	Operating Mode	01	UNSIGNED8	RW	0
200E		ARRAY	Reset Input Latch		UNSIGNED8		0
	00h	VAR	Number of entries	02	UNSIGNED8	RO	
	01h	VAR	Reset Input Latch 1 – 8	00	UNSIGNED8	RW	
	02h	VAR	Reset Input Latch 9 – 16	00	UNSIGNED8	RW	
2010		ARRAY	Value Time		UNSIGNED16		0
	00h	VAR	Number of entries	10	UNSIGNED8	RO	
	01h	VAR	Value Time 1	0000	UNSIGNED16	RW	
	02h	VAR	Value Time 2	0000	UNSIGNED16	RW	
	03h	VAR	Value Time 3	0000	UNSIGNED16	RW	
	04h	VAR	Value Time 4	0000	UNSIGNED16	RW	
	05h	VAR	Value Time 5	0000	UNSIGNED16	RW	
	06h	VAR	Value Time 6	0000	UNSIGNED16	RW	
	07h	VAR	Value Time 7	0000	UNSIGNED16	RW	
	08h	VAR	Value Time 8	0000	UNSIGNED16	RW	
	09h	VAR	Value Time 9	0000	UNSIGNED16	RW	
	0Ah	VAR	Value Time10	0000	UNSIGNED16	RW	
	0Bh	VAR	Value Time 11	0000	UNSIGNED16	RW	
	0Ch	VAR	Value Time 12	0000	UNSIGNED16	RW	
	0Dh	VAR	Value Time 13	0000	UNSIGNED16	RW	
	0Eh	VAR	Value Time 14	0000	UNSIGNED16	RW	
	0Fh	VAR	Value Time 15	0000	UNSIGNED16	RW	
	10h	VAR	Value Time 16	0000	UNSIGNED16	RW	
2011		ARRAY	Read Input Latch		UNSIGNED8		0
	00h	VAR	Number of entries	02	UNSIGNED8	RO	
	01h	VAR	Read Input Latch 1 – 8	00	UNSIGNED8	RO	
	02h	VAR	Read Input Latch 9 – 16	00	UNSIGNED8	RO	
2012		ARRAY	Read Input Wait		UNSIGNED8		0
	00h	VAR	Number of entries	02	UNSIGNED8	RO	
	01h	VAR	Read Input Wait 1 – 8	00	UNSIGNED8	RO	
	02h	VAR	Read Input Wait 9 – 16	00	UNSIGNED8	RO	
3000		VAR	Node Address	7F	UNSIGNED8	RO	0
3001		VAR	Node Baudrate	06	UNSIGNED8	RO	0
6000		ARRAY	Read Input 8 – bit		UNSIGNED8		M
	00h	VAR	Number of entries	02	UNSIGNED8	RO	
	01h	VAR	DigInput8_1	00	UNSIGNED8	RO	
	02h	VAR	DigInput8_2	00	UNSIGNED8	RO	
6002		ARRAY	Polarity Input 8 – bit		UNSIGNED8		0
	00h	VAR	Number of entries	02	UNSIGNED8	RO	
	01h	VAR	Polarity8_1	00	UNSIGNED8	RW	
	02h	VAR	Polarity8_2	00	UNSIGNED8	RW	
6003		ARRAY	Filter Constant Input 8 – bit		UNSIGNED8		0
	00h	VAR	Number of entries	02	UNSIGNED8	RO	
	01h	VAR	FilterConst8_1	00	UNSIGNED8	RW	
	02h	VAR	FilterConst8_2	00	UNSIGNED8	RW	
6005		VAR	Global Interrupt Enable Digital	TRUE	BOOLEAN	RW	0
6006		ARRAY	Interrupt Mask Any Change 8 - bit		UNSIGNED8		0
	00h	VAR	Number of entries	02	UNSIGNED8	RO	
	01h	VAR	InterruptAnyChange8_1	FF	UNSIGNED8	RW	
	02h	VAR	InterruptAnyChange8_2	FF	UNSIGNED8	RW	
6007		ARRAY	Interrupt Mask Low to High 8 - bit		UNSIGNED8		0
	00h	VAR	Number of entries	02	UNSIGNED8	RO	
	01h	VAR	InterruptLowToHigh8_1	00	UNSIGNED8	RW	
	02h	VAR	InterruptLowToHigh8_2	00	UNSIGNED8	RW	
6008		ARRAY	Interrupt Mask High to Low 8 - bit		UNSIGNED8		0
	00h	VAR	Number of entries	02	UNSIGNED8	RO	
	01h	VAR	InterruptHighToLow8_1	00	UNSIGNED8	RW	
	02h	VAR	InterruptHighToLow8_2	00	UNSIGNED8	RW	

* The factory set (value present in the modules when new) for the transmission type is: **01h**.