

Industrial Operator Panel with 4.3" wide screen colour graphic display **OP MT** line **6050iV** model

- 4.3" color graphic display
- 65536 color TFT LCD display
- 32 Bit 400 MHz RISC processor
- LED backlight
- 480 x 272 pixels resolution
- 4 wire analog resistive touch screen
- Connection to industrial bus systems (more than 100 drivers)
- 64 MB DRAM user memory, 128 MB flash memory on board
- NEMA4 / IP65 front panel protection
- Programmable with Easy Builder 8000 software (optional)
- Display data in alphanumeric and graphic formats
- Dynamic graphic objects (bargraphs, gauges, XY plot, etc.)
- Data acquisition and trend presentation
- Alarms and historical alarm list
- Up to 7 levels of password protection
- USB 2.0 high speed client port
- CE / RoHS certifications



E

ASCON spa

Via Falzarego, 9/11 - 20021 Baranzate - (Milano) Italy - Tel. +39 02 333 371; Fax +39 02 350 4243
<http://www.ascon.it> - e-mail: sales@ascon.it

ASCON Corporation

Tel.: +1 630 482 2950; Fax: +1 630 482 2956
<http://www.asconcorp.com>
 e-mail: info@asconcorp.com

ASCON France

Tél.: +33 (0) 1 64 30 62 62; Fax: +33 (0) 1 64 30 84 98
<http://www.ascon.fr>
 e-mail: ascon.france@ascon.fr

ISO 9001 Certified

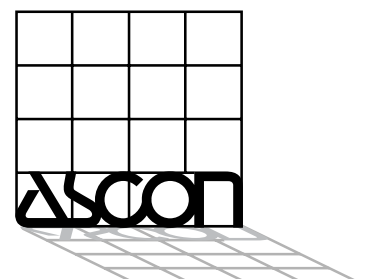

Technical data

Display	
Type	65536 color TFT
Graphic resolution	480 x 272 pixels
Active display area	4.3" diagonal
Pixel pitch (H x V)	0.198 x 0.198
Viewing angle (T / B / R / L)	50° / 70° / 70° / 70°
Backlight	LED
Brightness	450 cd/m ²
Contrast ratio	500 : 1
Backlight life time	30000 hours
Memory	
User memory	64 MB on board
Storage memory	128 MB Flash on board
Interfaces	
Com1 port	RS232/RS485, 2 or 4 wires
USB	1 USB 2.0 High Speed Device

Functionality	
Data acquisition and trends	Standard
Alarms	1024
Event list	1024
Password	Standard
Screen saver	Standard
Buzzer	Standard (audible feedback for touch screen)
Power supply voltage	24 Vdc ±20% (polarity sensitive)
Max. power consumption	~ 250 mA
Fuse	1.25 A
Weight	~ 0.3 kg (~ 0.66 lb)
Operating temperature	0...+45 °C (32...113°F)
Operating and storage humidity	10...90 % RH non-condensing
Protection class	NEMA4 / IP65 (front panel)

Product designed for installation in an industrial environment in compliance with the following regulations:

EMI: FCC class A
CE: EN50081-2, EN50082-2

Connections/Dimensions

Connections

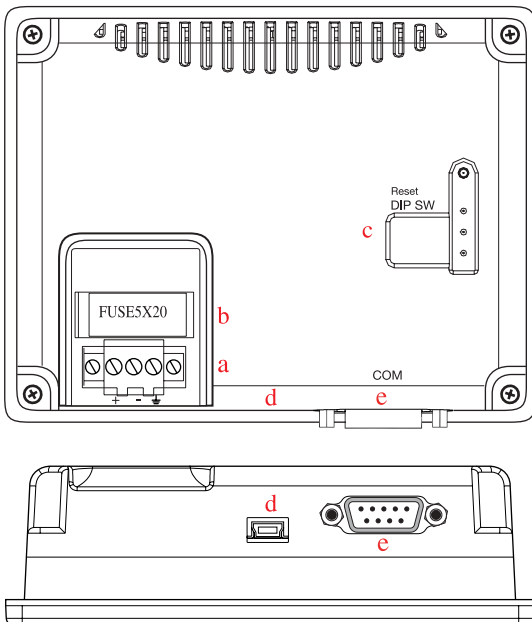

Cutout and front view

Panel dimensions L x H	128 x 102 mm	5.04 x 4.02"
Cutout A x B	119 x 93 mm	4.69 x 3.66"
Depth (type - 0045)	38.25 mm	1.51"
Max. panel thickness	7 mm	0.28"

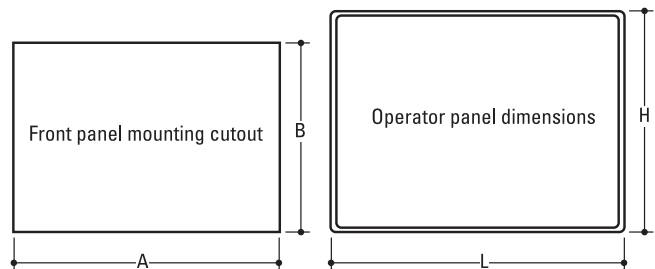

- a. Power terminals
- b. Fuse
- c. DIP switch and reset button
- d. USB 2.2 high speed client
- e. COM [RS-422/485]

Ordering code

