

# Indicator - Transmitter Strain Gauge Input for Melt Pressure & Load Cell Transducers 1/8 DIN - 96x48 mm gammadue® series, **J5** line



Accurate measurement of melt pressure and other process variables are provided by J5. The J5 is fully configurable from the keyboard or by means of a software configuration tool. The J5 display utilizes a large, bright 5 digit LED that can be configured to operate in green or red. The display can be configured to change color when in alarm condition.

- **Accuracy:** 0.1%
- **Measurement resolution:** 16 bit.
- **Overall response time:** 20 ms.
- **Display resolution:** configurable 1... 100 digit.
- **Main input:** 350Ω strain gauge, linear DC voltage and DC current. Square root extraction 32 segment linearizer for "custom" input.

- **Second input:** DC voltage and DC current. Suitable for temperature indication and signal conditioning (min., max., average, ratio, etc.) when combined with the Main input.
- **3 Digital inputs:** Independently configurable for alarms, display, and calibration handling...
- **Alarms:** 2 or 4 with ISA-A acknowledge.
- **Retransmission output:** optional, DC current
- **Communications:** optional, Modbus RS485.
- **Parameters protection:** 3 password levels.
- **Front protection:** IP65.

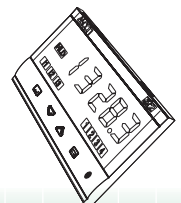
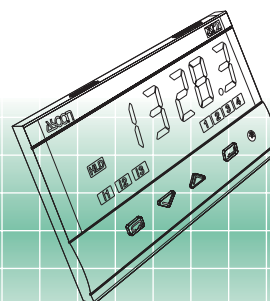
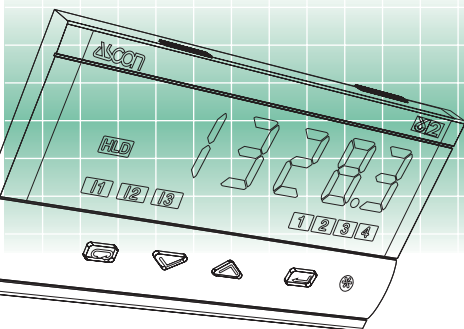

E

ISO 9001 Certified

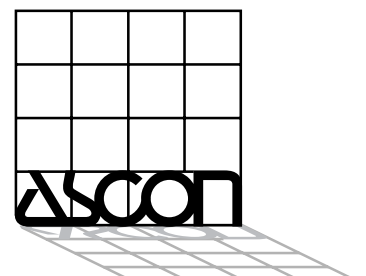



# gammadue®

the right solution to your needs

## J5 line

### The right solution for Melt pressure and Load cells applications

The 350Ω strain gauge bridge of the Melt pressure or load cell transducer can be energized by an internal stabilized 5 or 10Vdc. The reliability of the strain gauge is continuously monitored.

A simple front panel calibration routine is provided to automatically remove zero and span offsets. The automatic calibration routine can also be activated by using one of the three standard digital inputs, as well as being activated over serial communications. Tare function for load cells application is also provided.

Also available with the J5 indicator are: analogue retransmission, RS485 Modbus communications and additional configurable relay alarms with ISA type A alarm functions make the J5 indicator ideal to meet the most demanding monitoring requirements.

### Other configurable functions

**Keyboard lock/unlock:** to prevent unauthorized operator actions

**Outputs lock/unlock:** to set the outputs to OFF

**Max. or Min. of PV:** to display the maximum or the minimum stored value, using the MAX (max.) or MIN (min.) keys.

**Peak and Valley of PV:** to display the maximum and minimum read values in the following 2 modes

- 1) **Positive/Negative Hold Peak Display,** The displayed value is updated when higher/lower peak is detected.
- 2) **Positive/Negative Timed Peak Display,** The Peak value is displayed for a programmable period of time.

**HOLD PV:** The inputs and all the other functions (alarms, retransmission, etc.) are frozen on the last value until the Hold PV is active.

**Conditioned Input (CIN):** CIN is the result of IN1 conditioned by IN2.

**NO/NC Alarm status:** The relay contact status can be configured by default as either Normally Open (NO) or Normally Closed (NC).

### Display and key functions in operator mode

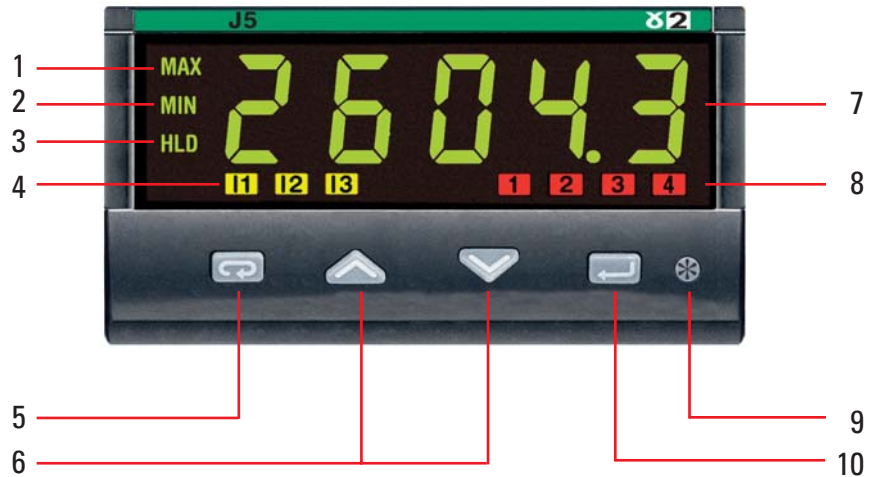

- |   |                      |   |           |   |
|---|----------------------|---|-----------|---|
| 1 | <b>MAX</b>           | Lit when the display shows the "Maximum value"                | 7         | Dual colour, 5 digit display  |
| 2 | <b>MIN</b>           | Lit when the display shows the "Minimum value"                | 8 1,2,3,4 | Alarm output status LEDs  |
| 3 | <b>HLD</b>           | Lit when the input is frozen by the HOLD command              | 9         | Alarm acknowledge, Reset Min./Max. stored values  |
| 4 | <b>IL1, IL2, IL3</b> | Digital input status LEDs                                     | 10        | Scanning of: Main input IN1, Second input IN2, Conditioned input value CIN, Min, and Max, values of IN1 or CIN, Engineering unit, Keyboard lock |
| 5 |                      | Access to Parameters & Calibration menu, (password protected) |           |   |
| 6 |                      | Displays the Minimum stored value                             |           |   |
|   |                      | Displays the Maximum stored value                             |           |   |

### Resources

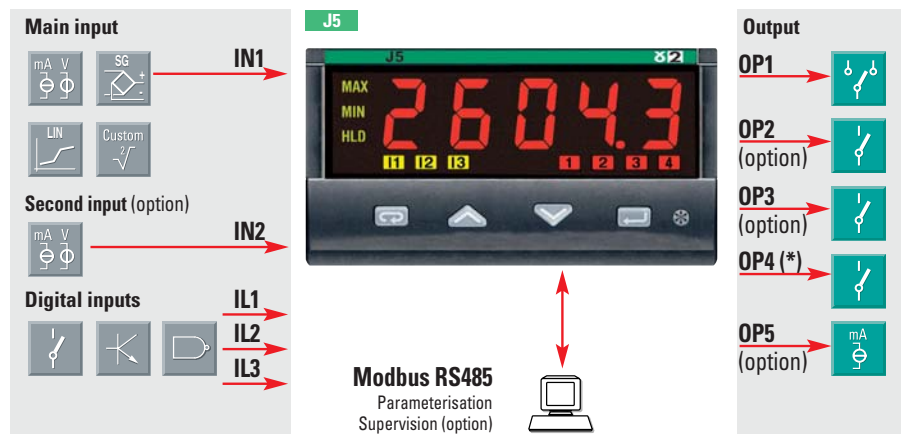

#### Configurable functions



#### Digital inputs (IL1, IL2 or IL3) functions



\* Note: OP4 output can be used for calibration shunt when strain gauge automatic calibration is required.

## Technical data

Features at 25°C env. temp.	Description		
Dual colour display	5 digit, high efficiency, height 15 mm, limits: -19999... 999999 red or green configurable depending on the user needs and/or the alarm status		
IN1 Main input (for signal ranges see "Ordering codes")	Common characteristics	A/D converter with 16 bit resolution Overall response time: 20 ms Input shift: ±1000 digit Input filter: 1...30 s (OFF= 0)	
	Accuracy	0.1% ±1 digit; between 85...240 Vac the error is negligible	
	Strain gauge bridge excitation	5V/10V selectable	From 350Ω... 10kΩ bridge load
	DC input Current	0/4... 20 mA	Engineering units, Floating decimal point,
DC input Voltage	0...20 mV 0...1 V 0...50 mV 0...5 V 0...100 mV 0...10 V	Display resolution: 1, 2, 5, 10, 50, 100 digit selectable	
IN2 Second input (option)	DC Current	0/4... 20 mA R input = 60Ω	Accuracy 0.1%
	DC Voltage	1/0...5, 0...10 V	Sampling rate 250 ms
Digital inputs (3 logic not isolated from internal electronics)	The voltage free contact closure enables:	Keyboard lock, Output block, Alarm acknowledge, Min./Max. reset, Measure hold, Peak or Valley hold, Display variable select, Strain gauge calibration, Tare set	
OP1 output	SPDT relay, 2A/250Vac (4A/120Vac) for resistive load		
OP2 output (opt.)	SPST relay N.O., 2A/250Vac (4A/120Vac) for resistive load		
OP3 output (opt.)	SPST relay N.O., 2A/250Vac (4A/120Vac) for resistive load		
OP4 output	SPST relay N.O., 2A/250Vac (4A/120Vac) for resistive load		
OP5 analogue output (option)	0/4...20mA, 750Ω/15V max. To retransmit: IN1, IN2 or CIN		
	Accuracy: 0.1% Resolution: 12 bit Galvanic isolation: 500Vac/1min		
AL1 - AL2 - AL3 - AL4	Hysteresis	0.1...10.0%	
	Action	Active high	Changing rate threshold 0.1...5.0 digit/s Deviation threshold ± range Band threshold 0...range Absolute threshold whole range
		Active low	
		Special functions	
Serial comms. (optional)	RS485 isolated, Modbus/Jbus protocol, 1200, 2400, 4800, 9600, 19200, 36400, 56800 bit/s, 3 wire		
Auxiliary power supply	+24Vdc ±20%, 30 mA max. for a 4... 20 mA, 2 wire transmitter		
Operational safety	Input measure	Detection of out of range, short circuit or sensor break with automatic activation of the safety strategy and alerts on display	
	Parameters	A non volatile memory stores for unlimited time all the configuration and parameter values	
	Access protection	3 password levels to access the strain gauge calibration, Configuration and Parameters data, Keyboard lock, Outputs Block	
General characteristics	Power supply	100...240Vac (-15...+10%) 50/60Hz or 24Vac (-25...+15%) 50/60Hz and 24Vdc (-15...+25%)	Power consumption 4W max. (PTC protected)
	Safety	Compliance EN61010-1 (IEC 1010-1), installation class 2 (2.5kV) pollution class 2, class II instrument	
	Electromagnetic compatibility	Compliance to the CE standards for industrial systems and equipment	
	UL & cUL approval	File E176452 (pending)	
	Protection EN60529 (IEC529)	IP65 front panel	
	Dimensions	1/8 DIN - 96 x 48, depth 110 mm, weight 250g approx.	

## Measure conditioning

Primary input IN1 can be Conditioned by the secondary input IN2; the conditioned input (C<sub>in</sub>) can be:

Id	Description
<i>i</i> n1	Cin = IN1
<i>i</i> n2	Cin = IN2
<i>S</i> u $\bar{n}$	Cin = IN1 + IN2
<i>S</i> u $\bar{b}$	Cin = IN1 - IN2
<i>A</i> v $\bar{g}$	Cin = (IN1 + IN2)/2
<i>H</i> ig	Cin = MAX (IN1, IN2)
<i>L</i> o $\bar{w}$	Cin = Min (IN1, IN2)
<i>M</i> u $\bar{l}$	Cin = IN1 * IN2
<i>r</i> e $\bar{t}$	Cin = IN1/IN2

## Default display variable

Variables that must be displayed as default include:

Id	Description
<i>i</i> n1	Input 1
<i>i</i> n2	Input 2
<i>C</i> in	Conditioned input
<i>L</i> o	Minimum stored value
<i>H</i> i	Maximum stored value
<i>U</i> n $\bar{t}$	Selected engineering unit

## Electrical wiring

### DC input IN1

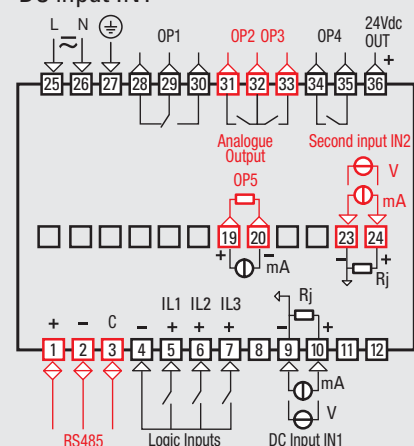

**Note:** Terminals in red are optional

### Strain gauge input IN1

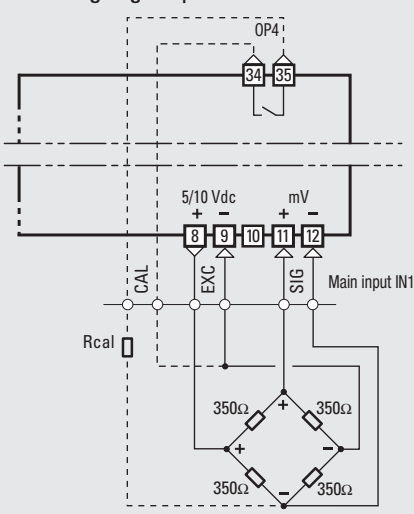

## Ordering Codes

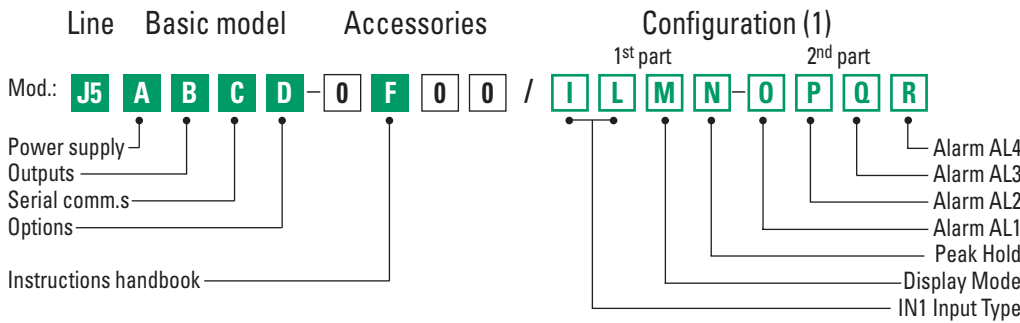

<b>Power supply</b>	<b>A</b>
100...240Vac (-15...+10%)	3
24Vac (-25...+12%) or 24Vdc (-15...+25%)	5
<b>OP1 OP2 OP3 OP4 (2) outputs</b>	<b>B</b>
Relay - - Relay	7
Relay Relay Relay Relay	9
<b>Serial communications</b>	<b>C</b>
Not fitted	0
RS 485 Modbus/Jbus SLAVE	5
<b>Options</b>	<b>D</b>
None	0
Analogue output for signal retransmission	1
Second port IN2	2
Analogue output for signal retransmission + Second port IN2	5
<b>Instruction handbook</b>	<b>F</b>
English (std)	8

<b>IN1 Input range</b>	<b>I</b>
DC input 0... 20mV	0
DC input 0... 50mV	1
DC input 0... 100mV	2
DC input 0... 1 V	3
DC input 0... 5 V	4
DC input 1... 5 V	5
DC input 0... 10 V	6
DC input 0... 20 mA	7
DC input 4... 20 mA	8

<b>IN1 Input type and excitation (3)</b>	<b>L</b>
Linear input mV, V, mA	0
Strain gauge transducer input, 5 V bridge excitation	1
Strain gauge transducer input, 10 V bridge excitation	2

<b>Display mode</b>	<b>M</b>
Green	0
Red	1
Red when alarm 1 (AL1) active	2
Red when at least one alarm is active (OR function)	3
Alternate between IN1, IN2 and CIN value	4
Manual forced display of IN1, IN2, CIN, Lo or Hi value	5

<b>Hold of the peak values</b>	<b>N</b>
Disabled	0
Shows the Max. value (HI peak) for a programmable period of time	1
Shows the Min. value (LO peak) for a programmable period of time	2

<b>AL1 - AL2 - AL3 - AL4 alarm type and function</b>	<b>O</b>	<b>P</b>	<b>Q</b>	<b>R</b>
Disabled	1	2	3	4
Sensor break alarm	0	1	2	3
Absolute	active high	2	3	4
	active low	3	4	5
Deviation	active high	4	5	6
	active low	5	6	7
Band	active out	6	7	8
	active in	7	8	-
Rate alarm (AL1 only)	8	-	-	-

### Notes:

- If the configuration code is not specified, the J5 is supplied with the default configuration: J5 \_\_\_\_ - \_\_\_\_ / 0000 - 0000.
- OP4 output can be used for high end scale calibration of the strain gauge.
- Configuration examples:
  - For strain gauge transducer rated 350Ω, 3.3 mV/V, 10 V excitation Voltage, select: **I: 1, L: 2;**
  - For standard transmitter 4... 20 mA output, select: **I: 8, L: 0.**

### ASCON spa

Via Falzarego, 9/11  
20021 Baranzate  
(Milano) Italy  
Tel. +39 02 333 371  
Fax +39 02 350 4243  
<http://www.ascon.it>  
sales@ascon.it

### ASCON FRANCE

2 bis, Rue Paul Henri Spaak  
ST. THIBAUT DES VIGNES  
F-77462 LAGNY SUR MARNE  
- Cedex  
Tél. +33 (0) 1 64 30 62 62  
Fax +33 (0) 1 64 30 84 98  
ascon.france@wanadoo.fr

### AGENCE EST

Tél. +33 (3) 89 76 99 89  
Fax +33 (3) 89 76 87 03

### AGENCE SUD-EST

Tél. +33 (0) 4 74 27 82 81  
Fax +33 (0) 4 74 27 81 71

### ASCON CORPORATION

472 Ridgelawn Trail  
Batavia, Illinois 60510  
Tel. +1 630 482 2950  
Fax +1 630 482 2956  
[www.asconcorp.com](http://www.asconcorp.com)  
info@asconcorp.com

### WORLDWIDE NETWORK OF DIRECT SALES CENTERS, DISTRIBUTORS AND VARs

#### Europe

Belgium, Croatia, Czech Rep., Denmark, Estonia, Finland, France, Germany, Great Britain, Greece, Holland, Ireland, Norway, Poland, Portugal, Romania, Russia, Slovakia, Slovenia, Spain, Sweden, Switzerland, Turkey, Ukraine

#### Americas

Argentina, Brazil, Canada, Chile, Colombia, Ecuador, Mexico, Paraguay, Peru, Uruguay, Venezuela

#### Rest of the world

Algeria, Australia, China, Egypt, Hong Kong, India, Indonesia, Iran, Israel, Malaysia, Morocco, New Zealand, Pakistan, Saudi Arabia, Singapore, Taiwan, Thailand, Tunisia, South Africa & South East Africa, UAE