

deltadue[®] Series DIN Rail Control and Acquisition Modules on Fieldbus

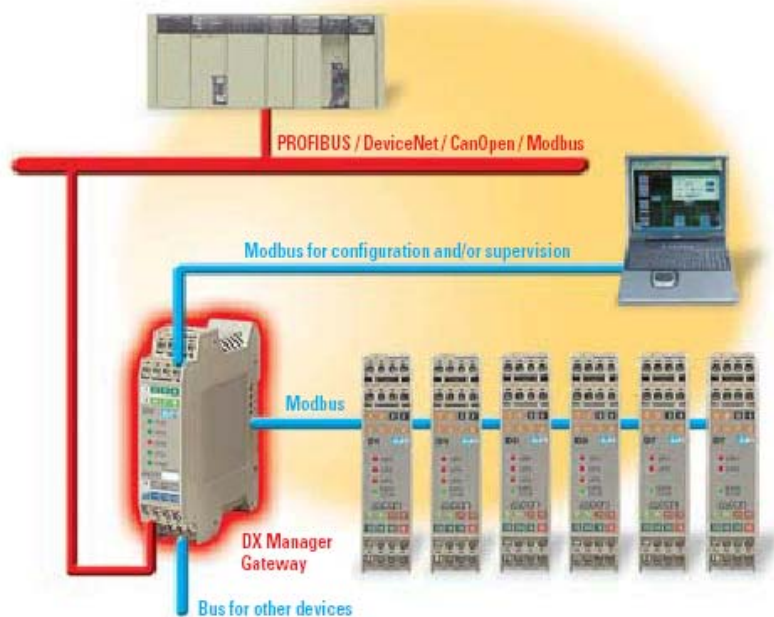

Modules
DX MB – DX PB

MODBUS – PROFIBUS
Gateway
and
delta2 Manager



User Manual

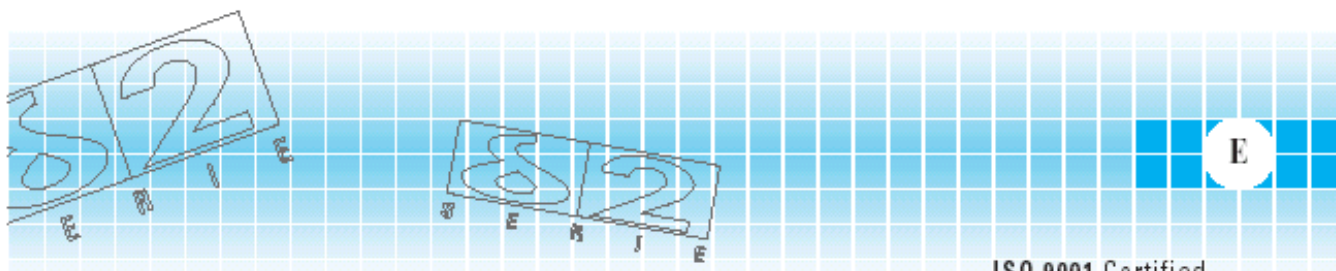

ISO 9001 Certified

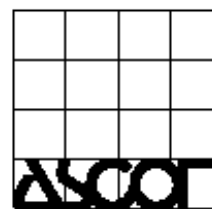

Revision table

Revision	Date	Changes	
1.0	30.11.2004	First edition	

Table of Contents[♦]

Preface	3
1. Introduction	6
2. Configuration and Operations	8
3. Commissioning and Running	18
4. Diagnostics and Service	30
5. Technical Data	31
Appendix A. MODBUS Maps	34
Appendix B. Suggestions and Examples	39
Appendix C. Definitions, Symbols and Conversion Tables	41

List of Figures

Figure 1 - delta2 DX : Communication Ports	7
Figure 2 - DX functional diagram	8
Figure 3 - Interleaving activities on Inst Bus	10
Figure 4 - Profibus telegram structure	13
Figure 5 - Service Port Functions Schematic diagram	18
Figure 6 - DX Terminal Blocks assignment	32
Figure 7 - RS485 MODBUS network topology	39
Figure 8 - PROFIBUS network topology	40

List of Tables

Table 1 - Data updating modes	11
Table 2 - Meaning of Status Coils	12
Table 3 - PROFIBUS Request and Response containers	14
Table 4 - Physical Protocol and Speed Converter	17
Table 5 - Dip Switch settings	20
Table 6 - Jumper settings	20
Table 7 - Diagnostic Read/Write Register for delta2 controllers	30
Table 8 - delta2 DX General Specifications	31
Table 9 - DX Terminal Blocks assignment	32
Table 10 - Signalling LEDs	33
Table 11 - Environmental Conditions	33
Table 12 - Registers Map	34
Table 13 - Coils Map	37
Table 14 - DX Status Register Read Mask (Register 8202)	37
Table 15 - DX Status Register Write Mask (Register 8202)	37
Table 16 - delta2 controllers MODBUS functions	38
Table 17 - Exception Codes	38
Table 18 - English Units - Metric Units Conversion Table	41
Table 19 - Temperature Conversion Table	41
Table 20 - Conductor Cross Section Conversion Table: mm ² - AWG (American Wire Gauge)	41

[♦] The information given herein is based on data believed to be reliable, but ASCON spa makes no warranty expressed or implied as to its accuracy and assumes no liability arising out of its use by others. This publication is not intended to be taken as a license to operate under any patent.

Preface

In order to guarantee the safe use of your device, we recommend that you read this manual carefully. The following notes give you information on how to use this manual.

Requirements of the User	3
Purpose of this manual.....	3
Using this manual	3
Getting started	4
Related documentation	4
Current documentation on the Internet.....	4
We are interested in your comments.....	5
Legal statement	5
Validity of documentation	5

Requirements of the User

The products described in this manual should be installed, operated and maintained only by qualified application programmers and software engineers, electricians or persons instructed by them, who are familiar with automation safety concepts and applicable national standards.

Ascon spa assumes no liability for damage to any product resulting from disregard of information contained in this manual.

Purpose of this manual

This manual contains the information necessary to understand and to configure the delta2 DX module.

This manual is written on the assumption that the reader possesses basic knowledge of Fieldbus techniques, in particular for PROFIBUS and MODBUS. Use this manual if you are responsible for configuring and installing ASCON delta2 modules with MODBUS interface.

Using this manual

Specifications within the text of this manual are given in the International System of Units (SI), with non SI equivalents in parentheses.

Fully capitalized words within the text indicate markings found on the equipment.

Words in bold style within the text indicate markings found in the Configuration Tools.

Warnings, Cautions and Notes are used to emphasize critical instructions:



WARNING

An operating procedure, practice, etc., which, if not carefully followed, could result in personal injury.



CAUTION

An operating procedure, practice, etc., which, if not strictly observed, could result in damage to the equipment.

NOTE

NOTE

Highlights important information about an operating procedure or the equipment.

For ease of looking for specific information in this manual, we have provided the following helps:

- A main table of contents covering all subject matter is provided at the front of this manual.
- A table of contents covering information within a section or an appendix is provided at the front of the individual section or appendix.
- Appendixes covering specific topics are provided following the last section in the manual.
 - MODBUS Addresses Map
 - Suggestions and examples
 - Definitions, symbols and conversion tables

Getting started

In the first section you are introduced to ASCON delta2 series of modules basics. The following sections contain general information that applies to all modules or module groups of the series. Topics are for example:

- Overview of the Inline product groups
- Modules structure
- Terminal installation and wiring
- Common technical data

Related Documentation

For additional information regarding PROFIBUS and MODBUS in general, refer to the documents issued by the respective Users Organisations.

If you need specific information on a delta2 module refer to the module-specific data sheets.

Current Documentation on the Internet

Make sure you are always working with the latest documentation published. The latest changes or additional information can be found on the Internet at:

<http://www.ascon.it>

ASCON Products pages are to be updated frequently. It is possible therefore that the Data Sheets published on the Internet would have a publishing date more recent than the date of the CD containing this manual.

We are interested in your comments

ASCON spa makes any effort to improve the quality of his manuals. Nevertheless errors and omissions are always possible. If you have suggestions or indications about the content or the form of this manual, ASCON spa will greatly appreciate your comments. You can send an e-mail to:

support@ascon.it

Legal statement

This manual, including all illustrations contained herein, is copyright protected. Use of this manual by any third party in departure from the copyright provision is forbidden. Reproduction, translation, and electronic or photographic archiving or alteration requires the express written consent of ASCON spa.

ASCON spa reserves the right to make any technical changes that serve the purpose of technical progress.

External products are always named without reference to patent rights. The existence of such rights shall not be excluded.

Validity of documentation

This manual mainly contains a description of delta2 DX PB and DX MB modules that were available when this manual was published.

ASCON spa reserves the right to make any technical extension and change to the equipments that would serve the purpose of technical progress. Up to the time that a new manual revision is published, any update or change will be documented on the Internet at:

<http://www.ascon.it>

1. Introduction

The module described in this manual belongs to the **ASCON delta2 series** of DIN rail mountable control, I/O and acquisition modules.

ASCON delta2 series

ASCON delta2 series goes to make up a complete, modular set of DIN mountable devices.

The versatile and compact delta2 modules are configurable from a PC and perform regulation and acquisition functions.

All of the modules are given a serial port, by which they can communicate with a remote PLC, SCADA system or PC, through an RS485 MODBUS Fieldbus.

delta2 series is composed by:

Controllers

- delta2 **D1**: temperature controller with Current Transformer input
- delta2 **D2**: Dual loop independent, isolated channels controller/analogue acquisition
- delta2 **D3**: Double action controller with analogue output

Analogue and digital acquisition modules

- delta2 **D7** Acquisition, isolation, transmitter with alarms
- delta2 **D9** 2 isolated Analogue acquisition Module
- delta2 **D8** 6 Inputs 2 Outputs Digital I/O Modules

Communication modules (Manager/Gateway)

- delta2 **DX PB** Manager/Gateway with PROFIBUS DP slave port
- delta2 **DX MB** Manager/Gateway with MODBUS/JBUS RS485 slave port
- delta2 **DX CB** Manager/Gateway with CANopen slave port
- delta2 **DX DN** Manager/Gateway with DeviceNet slave port

For detailed information please refer to the respective User's Manuals.

This manual gives operative information for: delta2 DX PB and DX MB

delta2 DX PB (DX MB) Module

delta2 DX modules are intended to manage a subsystem composed of ASCON delta2 series devices, all of them connected through a MODBUS serial line, hereafter indicated as **Inst Bus** (Instrumentation Bus).

delta2 DX modules are able to connect to a **Fieldbus** as well, as a slave node. In the case of this manual, to PROFIBUS DP for the DX PB and to MODBUS/JBUS for the DX MB.

A third communication Port (the **Service Port**) completes the picture. The Service Port is a MODBUS Master Port (carried over both an RS485 serial line and an RS232 serial line), dedicated to connect a PC for configuration purposes or an Operator Panel.

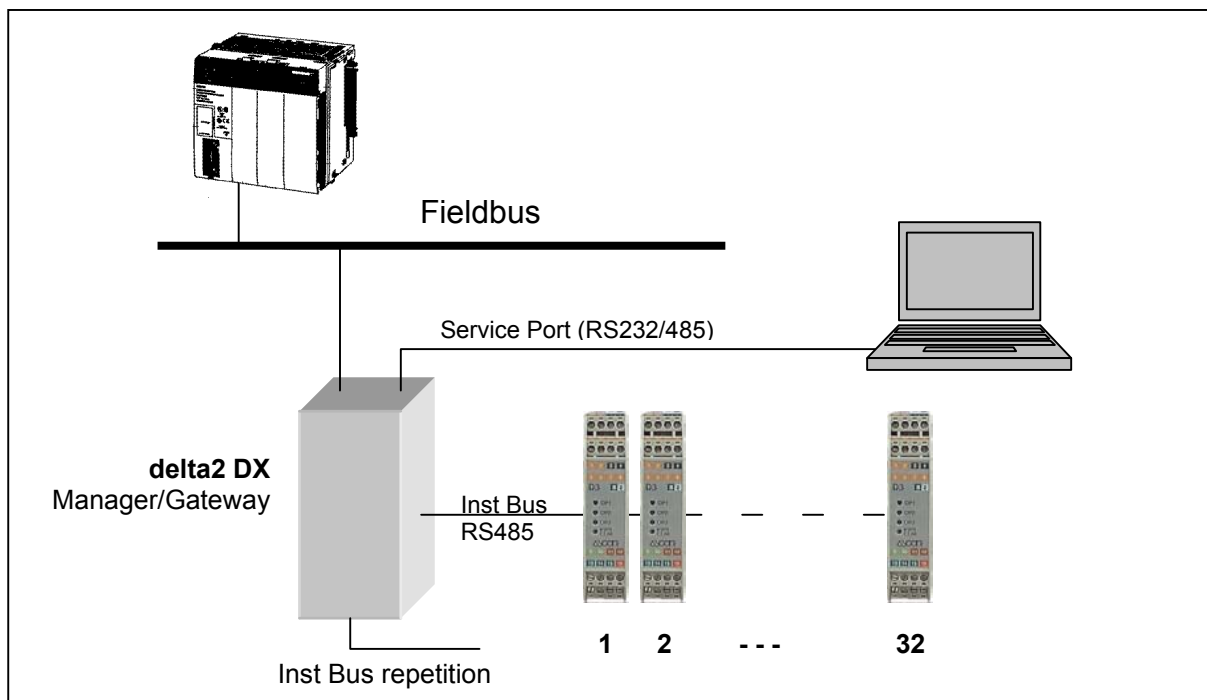

Figure 1 - delta2 DX : Communication Ports

Inst Bus is meant to connect MODBUS/JBUS RTU Slave devices, with Baud rate up to 19,2 kBaud, whereas the upper level network is generically called Fieldbus, since the DX can support a variety of protocols.

It's worth to say again that the delta2 DX module acts as Master node on the Inst Bus and as a Slave node on the upper level network.

The two main goals of the device are: to manage the configuration of delta2 devices in a completely automatic fashion and to allow the Fieldbus Master to gain access, as they were a unique node, to all the delta2 devices connected on the Inst Bus.

delta2 DX module acts therefore as a 3-port Communication Unit that carries out two important functions:

- **Manager function:**
This function allows the manual or automatic configuration of some devices connected to Inst Bus. Up to 32 devices are recognised by the Manager.
- **Gateway function:**
This function allows to establish a link between the MODBUS sub system (through Inst Bus) and the upper level network, in this case PROFIBUS DP (DX PB model) or MODBUS/JBUS (DX MB model).

Incidentally the delta2 DX module can perform a further auxiliary function: **Physical Interface Conversion** between RS232 and RS485 using the Inst Bus Port and the Service Port. It is understood that the logical protocol is MODBUS/JBUS in any case.

The most practical use of this function is to convert, at a different speed too, one RS232 MODBUS port into two RS485 MODBUS ports.

2. Configuration and Operations

As above mentioned, **delta2** DX module is basically a 3-port Communication Unit that carries out two important functions:

- **Manager function:**

This function allows an automatic configuration of delta2 modules sub system to take place.

Up to 32 modules are taken into account by the Manager. It can store in a non volatile memory the whole configuration set of ASCON delta2 controllers connected to Inst Bus, with the scope of:

- Execute real time diagnostics
- Automatic configuration of those controllers that have been substituted for failure or other needs.

- **Gateway function:**

This function operates the connection of a MODBUS sub system to an upper level Fieldbus, PROFIBUS DP for the DX PB model and MODBUS/JBUS for the DXMB model. It is essentially the equivalent of a **logic protocol converter** that acts between Inst Bus (MODBUS RTU) and the Fieldbus: the variables accessible on the Inst Bus are published on a FielBus.

Figure 2 reports the DX functional diagram, where the organisation of memory areas and the data flow between the different agents are evidenced.

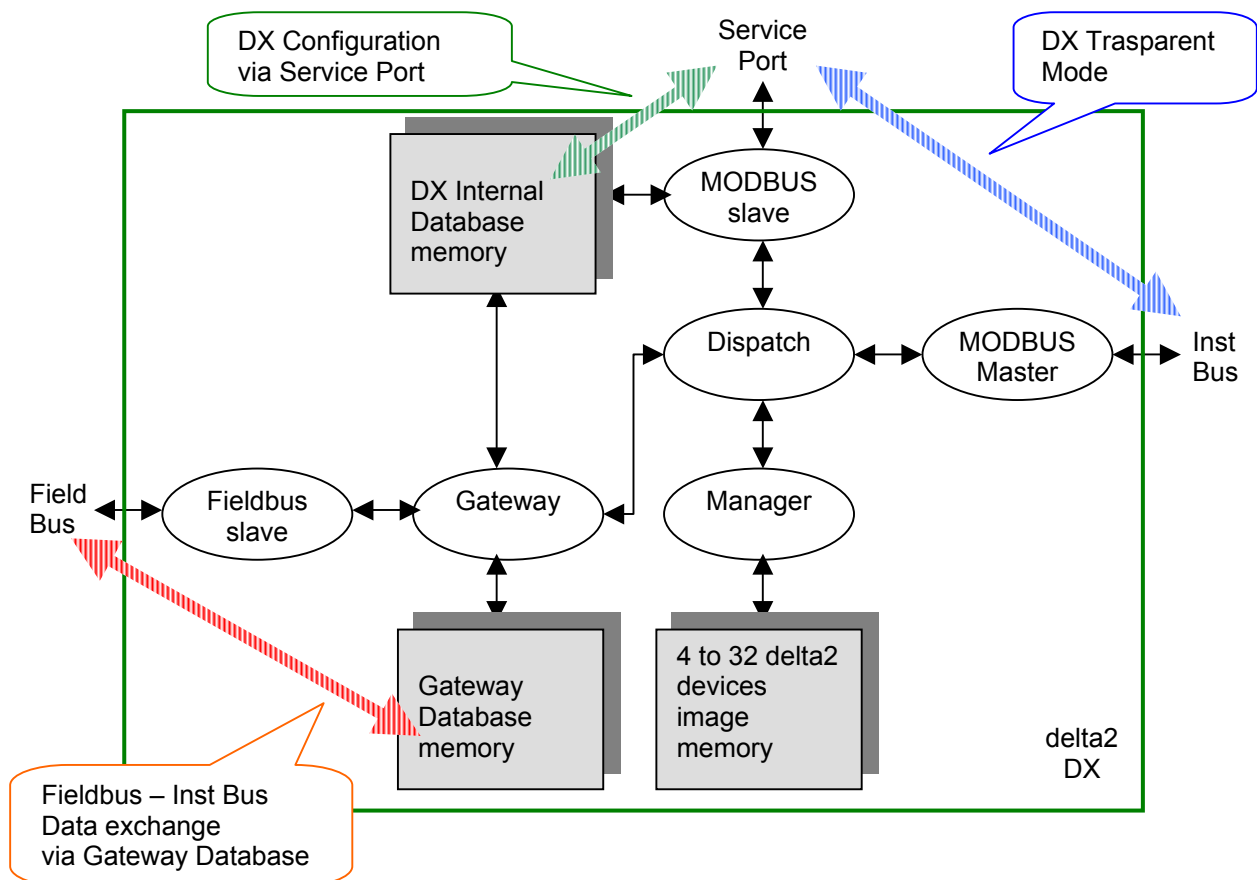

Figure 2 - DX functional diagram

The “**Manager**” function is composed by the set of functionalities that support the management and the diagnostics of the ASCON delta2 devices connected on the Inst Bus (the delta2 modules bus).

The maximum number of manageable devices is 32 (subject to order option code, in any case not greater than 32).

The Manager activities are interleaved with the normal communication activities on the Inst Bus, in order to check periodically the congruence between the devices image stored into the DX memory and the actual installed controllers.

An image of the delta2 devices sub system is stored into the internal DX Database (see Appendix A).

The Registers set from 8012 to 8171, contains the information for the identification of the delta2 controllers, that are:

- Device Node Address on the Inst Bus
 - 1st Product Code
 - 2nd Product Code
 - Hardware Code
 - Options Code
- 
- Controller Image Data

Furthermore, for each controller, an entire image of the configuration is stored; the mentioned data are only accessible through the Service Port in “Off-line Configuration” mode.

The Image Data update can be done by using the “Off-line Configuration” mode or by the “Self-learning” procedure.

Self-learning procedure

The Self-learning procedure executes an inquiry about the presence of delta2 controllers connected on the Inst Bus and then stores the Image Data into the DX internal Database. For this search, the procedure makes use of the node address interval specified by the 8006 and 8007 registers.

Automatic Configuration

This performance has the aim of automatically configure one or more controllers on the Inst Bus. It is useful when:

- A controller has to be replaced whilst running (e.g. for a failure)
- One or more controllers have to be added to the network.
In this case the corresponding Image Data must exist into the DX Database (e.g. having configured it by “Off-line Configuration” procedure from the Service Port.

NOTE

The Automatic Configuration service is active only for those controllers that have the “Diagnostics Activity” enabled.

NOTE

In case of devices replacement, be sure that the newly inserted device has been completely taken into account by the DX Manager before re-installing the field signals connectors. When it occurs (it will take a while) the ERR LED will turn to OFF.

During the Inst Bus periodic scan if the Manager detects the absence of a controller that should be present, it goes cyclically to search for a newly inserted controller (i.e. an

instrument that responds with the default data: Baud rate 9600, address 247, MODBUS protocol).

When such a device is detected the Manager verifies the congruence of the model and options of the newly detected device with respect to the stored image. If the device data are compatible, the Manager automatically configures the whole controller, including Baud rate and Node Address.

Doing that, the delta2 sub system will be taken in operating conditions again, as defined by the Image Data memory.

The absence of an expected device, i.e. the complete absence of communication activity, is the only condition that starts the hunting of a new controller to be automatically configured. This is done to avoid conflicts or collisions on the network.

The inquiries for a new device to be configured don't stop or limit the normal operating traffic on the network.

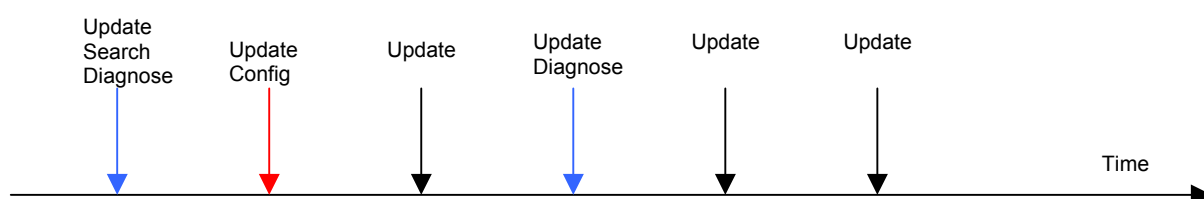

Figure 3 - Interleaving activities on Inst Bus

Besides being useful in "swapping" controllers in case of failures, this function is helpful during the installation phase.

In case of failure of more than one controller, scheduled in the configuration of delta2 network, the first newly inserted detected controller will be configured with the lowest address among those out of service.

NOTE The installation of a new system can be easily performed by simply configuring the Manager first, then by inserting the non configured controllers **sequentially one by one**. At each new insertion of a controller the Manager will configure it.

The writing out of the expected configuration information can be done in two ways:

- Configuring the Manager through the Service Port in Off-line mode
- Launching the Self-learning procedure¹.

NOTE Devices other than ASCON delta2 series can be present on the Inst Bus. These devices cannot be operated by the DX Manager; they simply are not taken into account by the Manager; nevertheless they can operate without limits on the Inst Bus.

The DX internal Database map is listed in Appendix A, together with some additional explanations.

¹ **NB:** Note that the Self-Learning procedure can be activated at Power On by setting the module Dip Switch n° 4 ON. Remember to reset the switch OFF at the end of the procedure.

The “**Gateway**” function automatically manages the access to the DX internal Database from both the Fieldbus Port and the Inst Bus.

NOTE For the **Gateway MODBUS** device the maximum managed number of Coils and Registers is:

- n° 128 Coils
- n° 200 Registers (Words)

NOTE For the **Gateway PROFIBUS** device the maximum managed number of Coils and Registers is:

- n° 128 Coils
- n° 44 Read Registers (Words) and n° 44 Write Registers (Words)

A **variable** that is accessible on the Inst Bus can be associated to every Database element of the Gateway. Each variable is identified by three parameters:

- Node address of the device hosting the variable
- Coil or Register address of the variable itself
- Updating mode.

The gateway area configuration table is then made by da 128 + 200 (or 44) triads of Registers (984 [or 516] Registers total), which are contained from address 9000 to address 9999 of the DX internal MODBUS Map (see Appendix A).

This configuration type is unrelated to the used Fieldbus; thus it is possible to locate on the Gateway Database the variables to be imported from the Inst Bus, and to define how data are to be updated, following the rules in Table 1:

Updating Modes	description
Read Variable	The Gateway Database variable is being updated continuously by cyclical readings on the Inst Bus of the corresponding associated variable
Write Variable	The Gateway Database variable is being updated from the Fieldbus side, consequently there isn't a read request on the Inst Bus. The related value will be transferred to the associated corresponding variable only when, after an update from Fieldbus, the new written value is different from what previously stored.
Read Write Variable	The Gateway Database variable update will be performed: <ul style="list-style-type: none"> • from the Fieldbus side, and directly write into the Database like a Write Variable (this operation consequently determines a write operation to the Inst Bus) • by cyclical readings on the Inst Bus The Fieldbus side Write operation will postpone the cyclical update from the Inst Bus until the consequent Write to the Inst Bus has been completed.
Disabled Variable	The Gateway Database variable still exists as a Database entry but it causes no activity on Inst Bus. As a consequence the congruency between the Database variable value and the corresponding associated Inst Bus variable value will be lost.

Table 1 - Data updating modes

It is possible as well to export the DX internal variables to the Gateway Database. This procedure allows for an access to the DX internal information from the Fieldbus Port, as well as from the Service Port.

To do this, the Node Address of the unit associated to the Gateway Database element should be set to 250. This Node Address identifies DX internal memory map.

The DX internal variables exported to the Gateway Database don't lead to any communication activity for update on the Inst Bus.

NOTE The DX internal variables, defining the Gateway own parameters (Registers from 9000 to 9999), and the Control Registers (8000, 8001) are not allowed to be published on the Gateway Database.

The communication activities from and to the Gateway Database concerning the Fieldbus and the Inst Bus are completely independent and have the Gateway Database as the sole interface. The transactions of the respective protocols are limited to access the Database and are not affected by possible other communication activities over the Service Port, due, for example, to Database updates.

In this context, the Gateway Database is supposed to be consistent when the current values of Database elements correspond to the actual values of the associated variables in the Inst Bus devices, or, at least, the communication activities for update are going on with no errors.

Diagnostics information are present in the DX internal map for a consistency check of the Database, since the consistency of the Database is not verifiable through the single access from Fieldbus. This is due to a non instantaneous update activity.

Every Database entry (Coils and Registers) owns an associated status Coil. The Coil, available in the DX internal map, identifies the current update status for each entry. The meaning of the status Coil is explained below.

Entry Status	Value	Meaning	Notes
Consistent	0	The communication activity for the update of the Database element, from and to the associated Inst Bus device, is correct.	Even in the absence of communication errors it is not guaranteed that, at any time, the associated variables have the same value. In fact the update activities are not coordinated; the result of a request of a variable on the Inst Bus is not guaranteed beforehand.
Non Consistent	1	The communication activity for the update of the Database element, from and to the associated Inst Bus device, is afflicted with errors. The values of the associated variables can be different.	The "Non Consistent" indication only means the presence of communication errors, so the synchronisation between associated variables has been, for some reasons, corrupted

Table 2 - Meaning of Status Coils

The transition to "1" of a Consistency check Coil is done by the DX itself when a number of communication errors arises (the number of consecutive errors is programmable in the "Gateway Error Trigger" Register 10003). Resetting errors is made only by resetting the single status Coil.

In addition, three further status Coils are available:

- 1328: Status of the whole Coils area
- 1329: Status of the whole Registers area
- 1330: Status of the whole Gateway area.

PROFIBUS Port

The DX acts, on the Fieldbus Port, as a PROFIBUS Slave DP/V0. The Node Address should be set in the "Gateway Node Address" Register (10000).

The PROFIBUS Port is able to detect automatically the communication Baud rate. The other Gateway communication parameters are meaningless (Registers 10001 and 10002).

The data exchange between the Fieldbus Port and delta2 controllers takes place by means of a "telegram", whose structure is defined in the following paragraph. The telegram is made up of two parts: the Service Container and the Data Container.

The Service Container, besides some communication service bytes², contains a point-to-point linking structure between the Fieldbus and a single variable belonging to a specific controller connected on the Inst Bus (Service Channel). By means of this mechanism it is possible to access to every single variable of all the connected controllers.

The Data Container holds the data (Coils and Registers) to be exchanged with the DX memory area that contains the connected controllers image.

Telegram Structure

The Receive and Transmit Telegrams have a fixed structure, as follows:

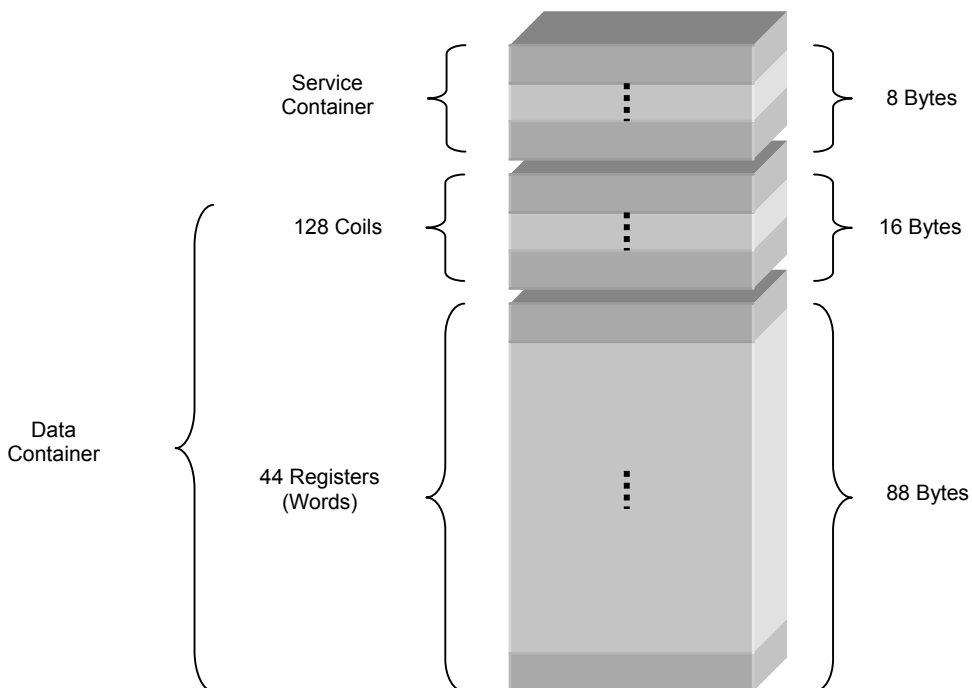

Figure 4 - Profibus telegram structure

² **NB** The first 8 Bytes are reserved to the basic functionalities of the PROFIBUS HMI profile, as defined in the document: PROFIBUS Profile, Order No. 3.082 Profile for Human Machine Interface-Systems (HMI). Revision 1.0, January 1998.

Coils Area

The Coils Area of the **Output telegram** (sent by Master) will be moved, coil by coil, to the Gateway Database Coils that are declared as Write and/or Read/Write variables.

The significant coils number is then equal to the number of the corresponding Gateway Database coils that have been declared as Write and/or Read/Write variables.

The Coils Area of the **Input telegram** (sent back by The DX in reply to the Master) will be filled by queuing the current values of the Gateway Database Coils that are declared as Read and/or Read/Write variables.

The significant coils number is then equal to the number of the corresponding Gateway Database coils that have been declared as Read and/or Read/Write variables.

Registers Area

The Registers Area of the **Output telegram** (sent by Master) will be moved, register by register, to the Gateway Database Registers that are declared as Write and/or Read/Write variables.

The significant registers number is then equal to the number of the corresponding Gateway Database registers that have been declared as Write and/or Read/Write variables. The maximum number of registers is 44.

The Registers Area of the **Input telegram** (sent back by The DX in reply to the Master) will be filled by queuing the current values of the Gateway Database Registers that are declared as Read and/or Read/Write variables.

The significant registers number is then equal to the number of the corresponding Gateway Database registers that have been declared as Read and/or Read/Write variables. The maximum number of registers is 44.

Service Container and Data Container

The communication model is intrinsically a Master-Slave model; the messages from a PLC (PROFIBUS Master) to the DX Fieldbus Port are called Request Containers and the messages from the DX (PROFIBUS slave) to a PLC are called Response Containers.

Each Container is made of two adjoining parts, one of fixed length named Service Container and one of variable length named Data Container.

The **Service Container** includes some flags for communication synchronisation and some information for the management of the "**Service Channel**". This channel is used for the point-to-point communication between a Master PROFIBUS PLC (or equivalent devices) and controllers connected to the DX Manager.

The contents of the **Data Container**, instead, are application-dependent and have variable length, adjustable by the user when configuring the system.

Request Container (PROFIBUS Message from PLC to delta2 DX Manager)		
Bytes 0..7	Service Container	Command Channel from PLC to delta2 DX Manager
Bytes 8..n	Data Container	Output from PLC

Response Container (PROFIBUS Message from delta2 DX Manager to PLC)		
Bytes 0..7	Service Container	Response Channel from delta2 DX Manager to PLC
Bytes 8..n	Data Container	Input to PLC

Table 3 - PROFIBUS Request and Response containers

Request Service Container details

Request Service Container								
Byte	00	01	02	03	04	05	06	07
	Control		Point-to-point delta2 Service Channel					
	Request Control Byte	spare	delta2 Slave	Command	Address Lo	Address Hi	Value Lo	Value Hi

The Request Control Byte contains communication control and command bits.

The remaining bytes (02..07) serves the point-to-point communication channel between the PLC and the Inst Bus (through DX Manager).

Request Control Byte

Request Control Byte								
Bit	7	6	5	4	3	2	1	0
	Request	Com	Toggle					

Operations:

- PLC sets **Request** Bit \neq Response Bit (see Response Service Container) to indicate that a new Request Service Container is available for processing.
- PLC sets Request **Com** = 1; DP protocol watchdog sets Response Com = 0 on delta2 Manager if the communication with PLC has been interrupted.
- Request **Toggle** always contains the opposite state of Response Toggle.
- Request **Toggle** state changes continuously as long as the program is correctly running for both the devices. This condition can be used as a "watchdog" warning.

Point-to-Point Service Channel

As already pointed out, the PLC uses the Service Channel to send commands to delta2 controllers on the Inst Bus:

- **delta2 Slave** is the MODBUS Node Address, on the Inst Bus, the request has to be sent to.
- **Command** is the command to be sent
- **Address** is the Register number to which Command is addressed
- **Value** is the value to be written, in case of a Write command.

Command can assume the following values:

Value	Command
4	Read Bit
5	Write Bit
6	Read Word
7	Write Word

Every other combination is **invalid** and give back an answer (see Response Service Container) with the **Error** bit = 1.

Response Service Container details

Response Service Container								
Byte	00	01	02	03	04	05	06	07
	Control		Point-to-point delta2 Service Channel					
	Response Control Byte	spare	delta2 Slave	Answer	Address Lo	Address Hi	Value Lo	Value Hi

The Response Control Byte contains communication control and command bits.

The remaining bytes (02..07) serves the point-to-point communication channel between the Inst Bus and the PLC (through DX Manager).

Response Control Byte

Response Control Byte								
Bit	7	6	5	4	3	2	1	0
	Response	Com	Toggle	Error	Error Code			

Operations:

- DX delta2 Manager sets **Response** Bit = Request Bit to indicate that the PLC request has been processed and a new Response Service Container is available.
- DX delta2 Manager sets Response **Com** = 1. DP protocol watchdog sets Request **Com** = 0 on PLC if the communication with delta2 Manager has been interrupted.
- Response **Toggle** always contains the opposite state of Request Toggle.
- Response **Toggle** state changes continuously as long as the program is correctly running for both the devices. This condition can be used as a "watchdog" warning.
- **Error** = 1 denotes that an error condition on DX has occurred. **Error Code** specifies the type of error.
- **Error Code** = (to be defined)

Point-to-Point Service Channel

As already pointed out, the DX Manager uses the Service Channel to send to the PLC the responses from delta2 controllers, attached on the Inst Bus, resulting from PLC commands:

- **delta2 Slave** is the MODBUS Node Address, on the Inst Bus, from which the response comes.
- **Answer** is the received response from the node.
- **Answer** can assume the following values: (to be defined)
- **Address** is the Register number to which the command was addressed.
- **Value** is the read value, in case of a Read Command.

MODBUS

In this case the DX acts, on the Fieldbus Port, as a MODBUS RTU slave device. The Node Address should be set in the "Gateway Node Address" Register (10000). Other communication parameters are to be set in the proper registers: Baud rate (Register 10001) and JBUS/MODBUS notation (Register 10002).

The MODBUS map available on Fieldbus side exactly corresponds to the Gateway Database, which is therefore directly accessible with 128 I/O in the Coils area and 200 Registers (input/holding).

It is possible as well to reach (indirectly through the DX Gateway) each and every register of any delta2 unit connected on the Inst Bus, by means of the DX internal registers 10004, 10005 and 10006.

It's worth to remember that some DX internal registers can be mapped on the Database by using the Node Address 250.

By the way, the registers 10004, 10005 and 10006 contain, respectively, the delta2 unit node address on the Inst Bus, the address of the register you want to reach on the unit and the image of the register itself.

Through this set of registers, a point-to-point virtual channel is created between the Fieldbus (MODBUS) and the single unit on the Inst Bus; this channel is similar to the Service Channel already described for PROFIBUS.

RS232/485 Physical Protocol Converter

Besides its primary functions (Manager and Gateway), the delta2 DX module can work as an RS232/485 – RS485 Physical Protocol Converter (Ordering code DX 5000). The logic protocol running on both the concerned ports must be MODBUS/JBUS.

This function can be applied to the ports listed below:

- The Service Port (RS232 or RS485)
- The twin Inst Bus RS485 Ports

This function is especially useful when, on the Inst BUS, there are some MODBUS controllers not belonging to ASCON delta2 family.

The two referred ports can work at different speed as well:

Converter	Physical Protocol	Communication speed
Service Port	RS232 or RS485	from 1.2 to 19.2 kBaud
Inst Bus Port	RS485	from 1.2 to 57.6 kBaud

Table 4 - Physical Protocol and Speed Converter

3. Commissioning and Running

The control of the various mode of functioning of the device is made through the Service Port. This port is a MODBUS RTU Slave Port.

Here below is a schematic diagram of the functions that can be activated through the Service Port:

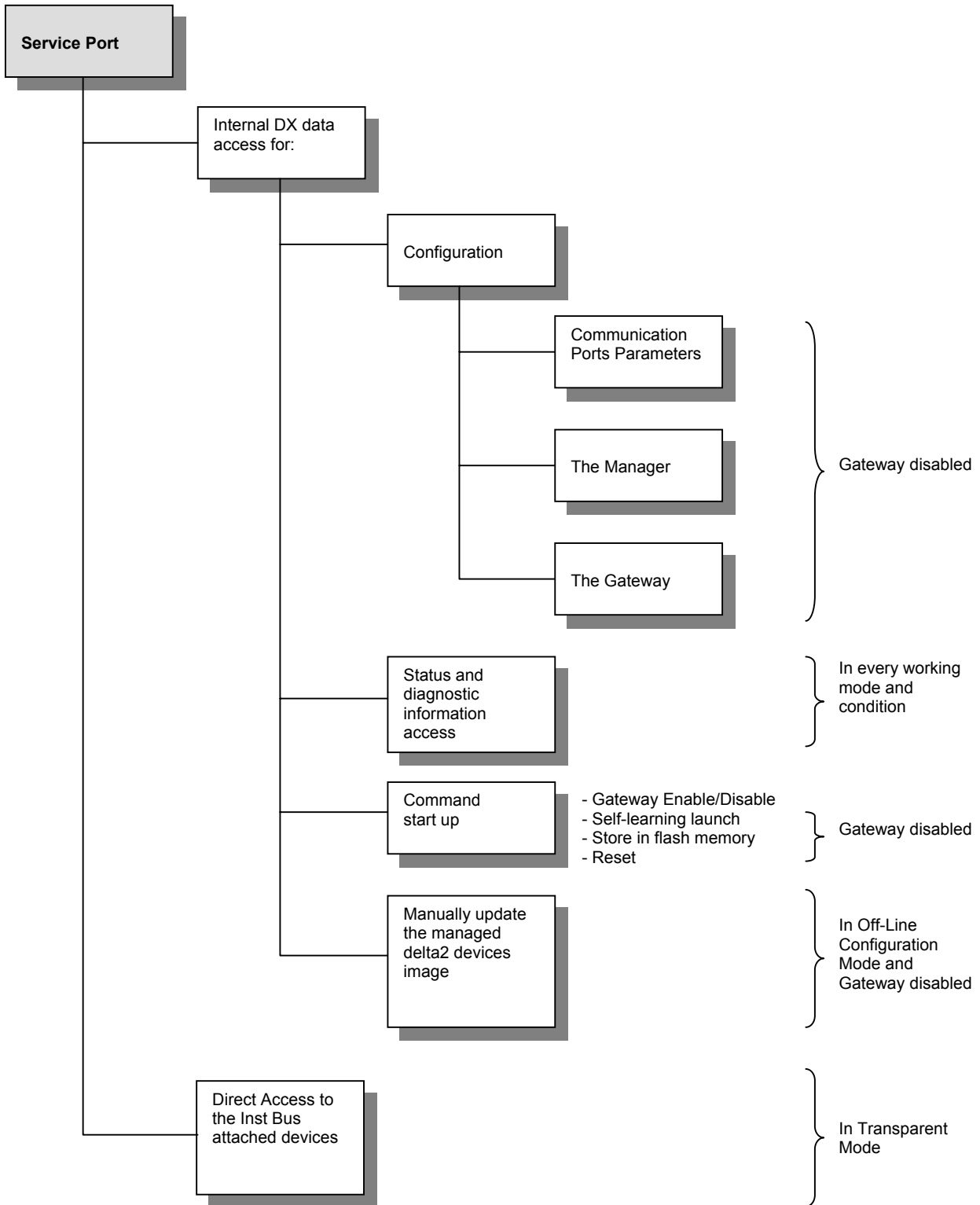

Figure 5 - Service Port Functions Schematic diagram

On the basis of the expected behaviour and performances, with reference to the previous figure, the following Operating Modes and Commands are meaningful:

- **Transparent Mode:**

Writing "0" to Register 8000 (default value at Power Up) causes the Service Port to go to "Transparent Mode".

The MODBUS commands received on the Service Port will be forwarded to Inst Bus as they are, in transparent mode and the response messages from delta2 devices will be replicated to the Service Port. In this operating mode the DX Manager acts as an RS232-485/RS485 converter, so it can work with the delta2 devices Configuration Tools.

- **Off-Line Configuration Mode:**

Writing "1" to Register 8000 causes the setting of "Off-Line Configuration Mode".

Off-Line procedure allows for a delta2 network to be configured even in the absence of the controllers on the network. For every expected controller, the "controller type", including options and its Inst Bus Node Address, are defined. After that the DX Manager is able to emulate the communication with the defined controller, through the Service Port.

A virtual image of each controller can be therefore stored in memory. This can be done by using an appropriate configuration Tool, for example the ASCON delta2 **Controller Explorer**. The real controller will be actually configured when physically inserted on the network and taken into account by the DX Manager during a subsequent network scan phase.

- **Gateway Configuration:**

Register 8000 = 2

This setting presets the Gateway memory structure to be able to exchange data between the Fieldbus and the Inst Bus. This is accomplished by defining the correspondence map between variables that are present on Inst Bus devices and the Gateway memory Registers set.

- **Self-Learning command:**

Writing "1" to Register 8002 the Self-Learning command is activated. The DX Manager operates a scan of the Inst Bus network and creates an image of the acknowledged devices³. For this search, the procedure makes use of the node address interval specified by the 8006 and 8007 registers.

NOTE

When the Self-Learning command has been executed, it is advisable to save the data in non volatile memory with the "**Store**" command (write bit 7 of DX Status Register 8202), followed by a "**Reset**" command (Registro 20000).

³ **NB:** Note that the Self-Learning procedure can be activated at Power On by setting the module Dip Switch n° 4 ON. Remember to reset the switch OFF at the end of the procedure.

Hardware settings

Some hardware settings are available on the Delta2 DX main board: four dip switches and three jumpers.

Dip Switch settings

The four Dip Switches allow to set the Inst Bus Baud rate and to activate automatically the Self-Learning procedure immediadely following the Power-Up phase.

By these two settings a DX Manager can easily duplicate a delta2 controllers network without the use of an external PC or other configuration tools.

The Dip Switches map is as follows:

Dip Switches				operation	
1	2	3	4		
Off	Off	Off	Off	1200	Inst Bus Baud rate Selection
On	Off	Off	Off	2400	
Off	On	Off	Off	4800	
On	On	Off	Off	9600	
Off	Off	On	Off	19200	
x	x	x	Off	Disabled	Self-Learning at Power-Up Remember to reset the switch 4 OFF at the end of the procedure
x	x	x	On	Force	
On	On	On	On	Reset parameters of communication ports Inst Bus and Service Port to default values: 9600, 8, N, 1	
x x x = any valid Baud rate value					

Table 5 - Dip Switch settings

NOTE Baud rate setting applies to the ordinary communication messages. The Self-Learning procedure always uses the 9600 value to scan the network, that is the factory default speed of a new delta2 device.

Jumper Settings

There are three Jumpers on the device’s main board:

Jumper	Inserted	Meaning
JP_RD1		Reserved – Do not insert
J_T485_D	X	120 Ohm Termination on Inst Bus inserted
J_T485_S	X	120 Ohm Termination on RS485 Service Port inserted

Table 6 - Jumper settings

NOTE Dip Switches and Jumpers are not accessible from the outer case. To make modifications or activate commands (e.g. Self-Learning or Reset) it is necessary to extract the main board from the case, make the desired actions and insert it again. If Power is ON, this operation makes implicitly an ON-OFF-ON cycle. Repeat the operation if some elements have to be restored.

DX Configuration

The parameters configuration for DX module operations is made by a software tool connected through the Service Port. The tool, ASCON **delta2 Manager**, runs on a service PC.

When **delta2 Manager** is launched, the Main Menu page appears, with an help page put beside:

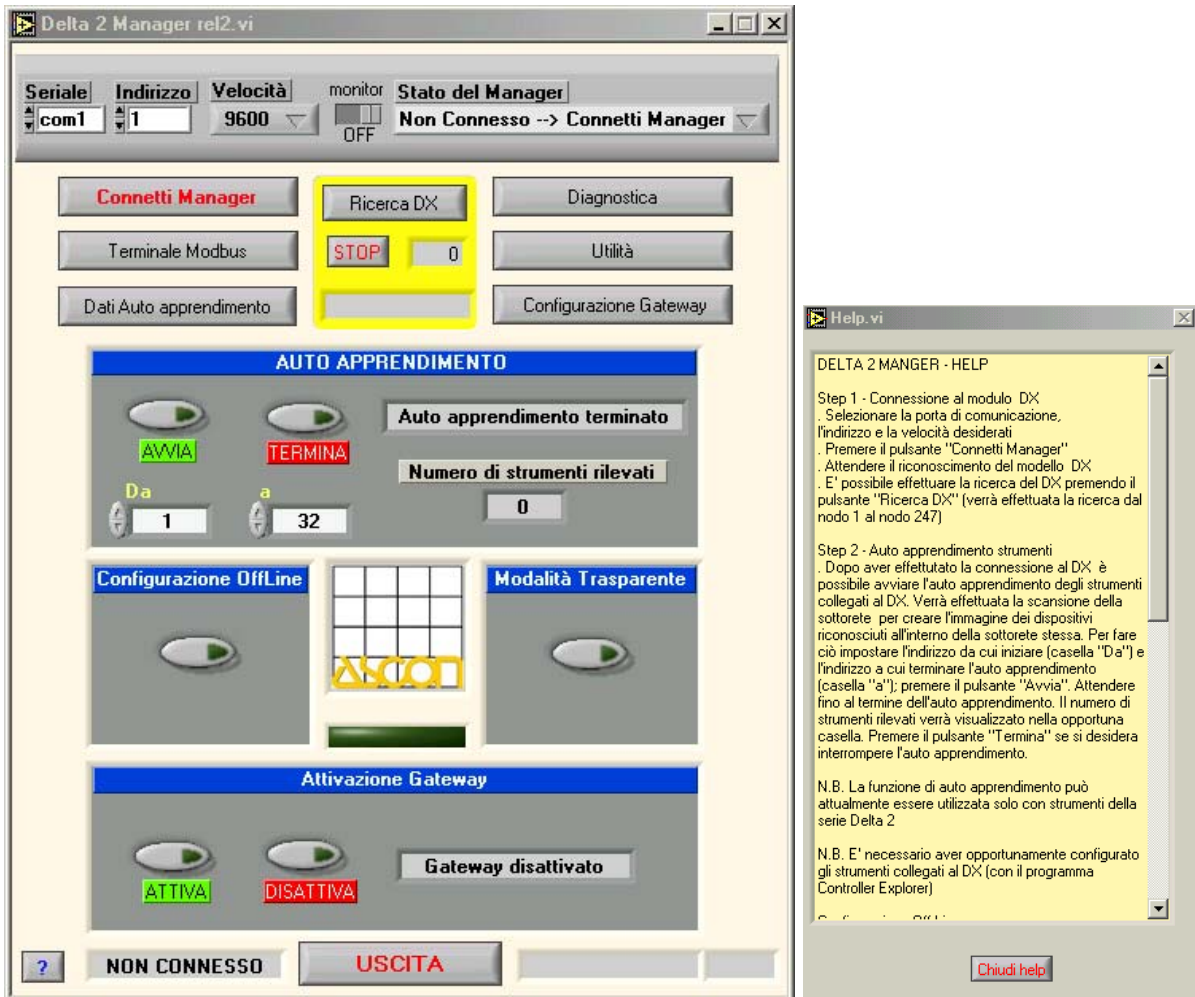

After having the Help page closed, it is possible to select the various configuration functions:

Connection to DX module

Select the PC communication port, the DX module address and communication speed. Choosing "0" as the DX address (see also the "Utility" page), it will answer whatever the configuration status is.

Press "**Connect**" button

Wait for DX model acknowledge

By hitting "**DX Search**" button, an automatic search will be initiated. After the scan (from node 1 to node 247) will have given a result, a new page, containing the most important information about the detected module will appear.

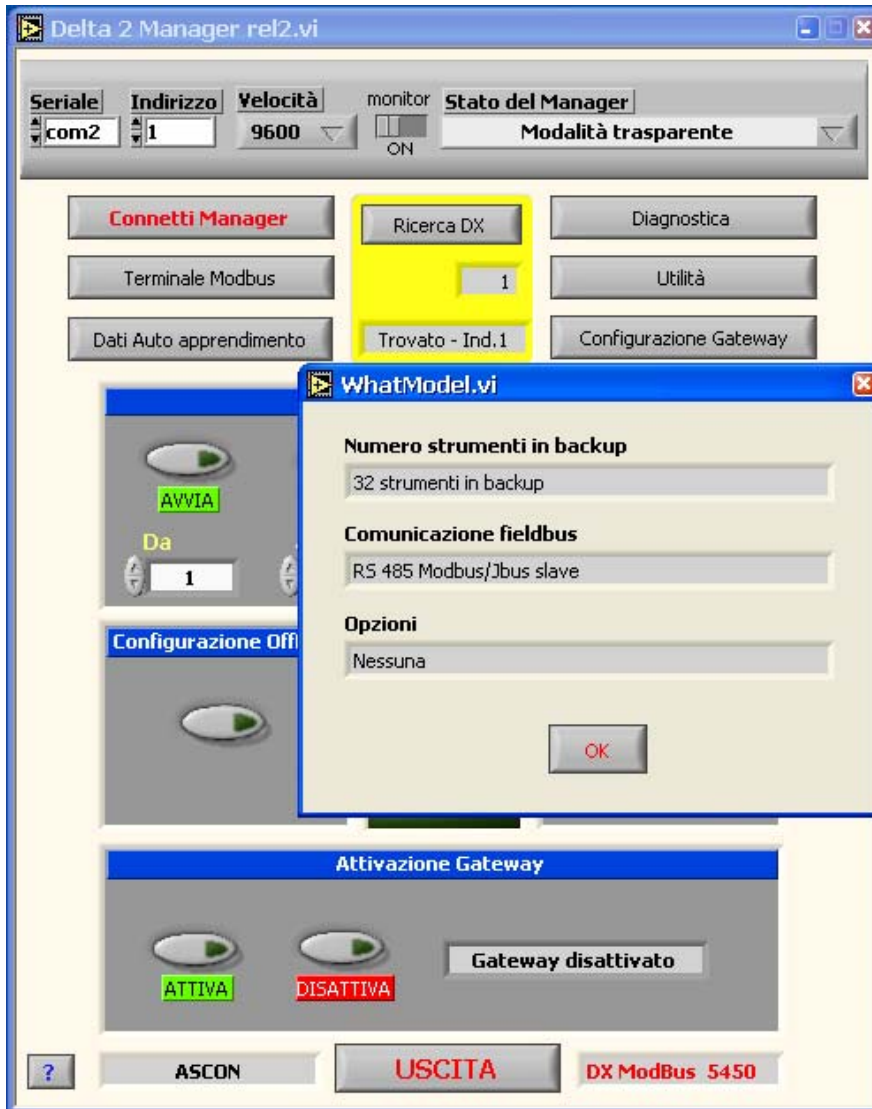

Self-Learning sub menu

After the DX connection, it may be advisable to launch a Self-Learning session, for the search of devices connected on the Inst Bus. In the main menu page (Self-Learning sub menu) fill the starting address box (box "**From**") and the ending address box (box "**To**"). Then press "**Start**" button and wait for the end of procedure. The number of found devices will be showed in the proper case. Press "**Stop**" button if you want to force a close. An image of all acknowledged devices will also be created in the DX memory.

NOTE

The Self-Learning function can only be used for ASCON delta2 series of devices.

NOTE

It is strongly recommended that the Self-Learning function is used only for already configured controllers, e.g. with the Controller Explorer program.

Off-Line Configuration

Off-Line procedure allows for a delta2 devices network to be configured even in the absence of the devices on the network. For every expected controller, the "controller type", including options and its Inst Bus Node Address, are defined. After that, the DX Manager is able to emulate the communication with the defined controller, through the Service Port. A virtual image of each controller can be therefore stored in memory. This

can be done by using an appropriate configuration Tool, for example the ASCON delta2 **Controller Explorer**. The real controller will be actually configured when physically inserted on the network and taken into account by the DX Manager during a subsequent network scan phase.

To set the DX to this operating mode press the " **Off-Line Configuration** " button. Then you can run the Controller Explorer program.

NOTE

The Off-Line Configuration mode can at the moment be used only for ASCON delta2 series of controllers.

Transparent Mode

While in Transparent Mode mode, MODBUS command received from Service Port are forwarded, as they are, to Inst Bus and the response messages from delta2 devices will be replicated to the Service Port. In this operating mode the DX Manager acts as an RS232-485/RS485 converter, so it can work with the delta2 devices Configuration Tools.

To set the DX to this operating mode press the "**Transparent Mode**" button.

Gateway Start Up (Option)

From Main Menu page it is possible to activate ("**ON**" button) and deactivate ("**OFF**" button) the Gateway functions. In order to have this operation working, the Gateway Database variables must be configured (see "Gateway configuration" menu).

NOTE

When the Gateway function is ON it is neither possible to launch a Self-Learning operation nor configure the Gateway itself.

The "**Monitor**" switch activates or disactivates the DX Monitor function. When the monitor is deactivated, the Gateway and Manager status information will not be updated.

From the Main Menu page, pressing the **"Utility"** button, the following page will be available:

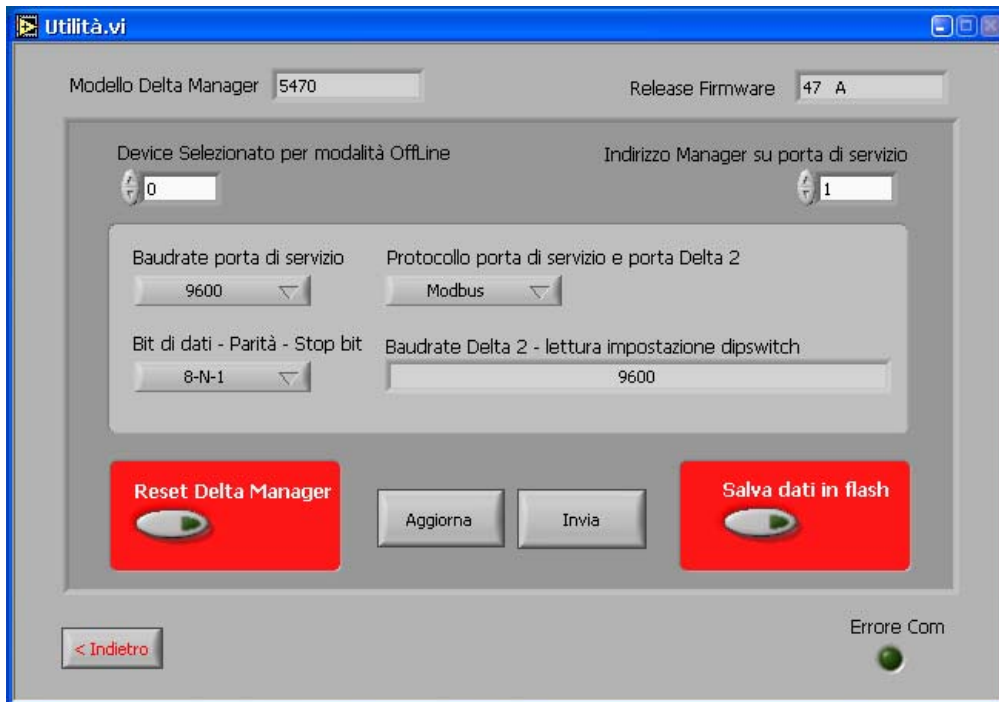

In this mask you can select and set some working parameters. The "delta2 DX model" refers to ordering code.

"Update" button shows the current DX values, whereas **"Send"** button transmits the new values to the DX. These last values can be definitively stored in DX non volatile memory (i.e. valid for every Power Up), by means of the **"Save Data"** button.

"DX Manager Reset" button re-initialise completely the DX, as following a Power Up.

After a Self-Learning procedure, from Main Menu page the detected data can be displayed. By hitting the **"Self-Learning Data"** button a report window will appear, where addresses, model numbers and codes of detected Inst Bus delta2 devices are summarised.

	Indirizzo	Modello	Codice		Indirizzo	Modello	Codice
Device 1	0		00	Device 17	0		00
Device 2	0		00	Device 18	0		00
Device 3	0		00	Device 19	0		00
Device 4	0		00	Device 20	0		00
Device 5	0		00	Device 21	0		00
Device 6	0		00	Device 22	0		00
Device 7	0		00	Device 23	0		00
Device 8	0		00	Device 24	0		00
Device 9	0		00	Device 25	0		00
Device 10	0		00	Device 26	0		00
Device 11	0		00	Device 27	0		00
Device 12	0		00	Device 28	0		00
Device 13	0		00	Device 29	0		00
Device 14	0		00	Device 30	0		00
Device 15	0		00	Device 31	0		00
Device 16	0		00	Device 32	0		00

From the "Report" page you can also **"Print"** the report, **"Reset Current Data"** and **"Start"** and **"Stop"** a new Self-Learning procedure, using the devices range identified by **"From"** and **"To"** boxes.

The **"Diagnostics"** button on Main menu page activates the display of the diagnostics page, that summarises the error status of each managed controller on Inst Bus. The **"Manager Control"** buttons, one for each controller, individually enable or disable the diagnostic check. In the "Errors" boxes the number of communication errors are evidenced.

Two total enable and disable switches and a total **"Errors Reset"** button are also available.



By hitting the **"Options"** button, a window will appear, where you can configure the diagnostic cycle. Three parameters are to be set: the time between two consecutive interrogations (in hundredth of seconds), the cycle duration time (in seconds) and the number of scan cycles between two consecutive diagnostic cycles.

The **"Send"** button causes the parameters to be sent to DX Manager. The **"Save"** button causes the parameters to be permanently stored in non volatile memory (i.e valid at next OFF-ON cycle)



Gateway Configuration

Another important action that can be made from Main Menu page is "**Gateway Configuration**". A window appears and Gateway parameters can be set. For PROFIBUS DP the only parameter to set is Profibus Node Address. For MODBUS, Baud rate and protocol type shall be picked as well.

"**Update**" button shows the current DX values, whereas "**Send**" button transmits the new values to the DX. These last values can be definitively stored in DX non volatile memory (i.e. valid for every Power Up), by means of the "**Save Data**" button.



By hitting the **“Gateway Variables Configuration”** button you can enter the compilation of internal Gateway Database. By this activity you can choose and publish the delta2 controllers variables towards the Fieldbus.

After having chosen the variables configuration mode (by address,...):



the real configuration page appears. Now it is possible to compile Coils and Registers of the selected devices.

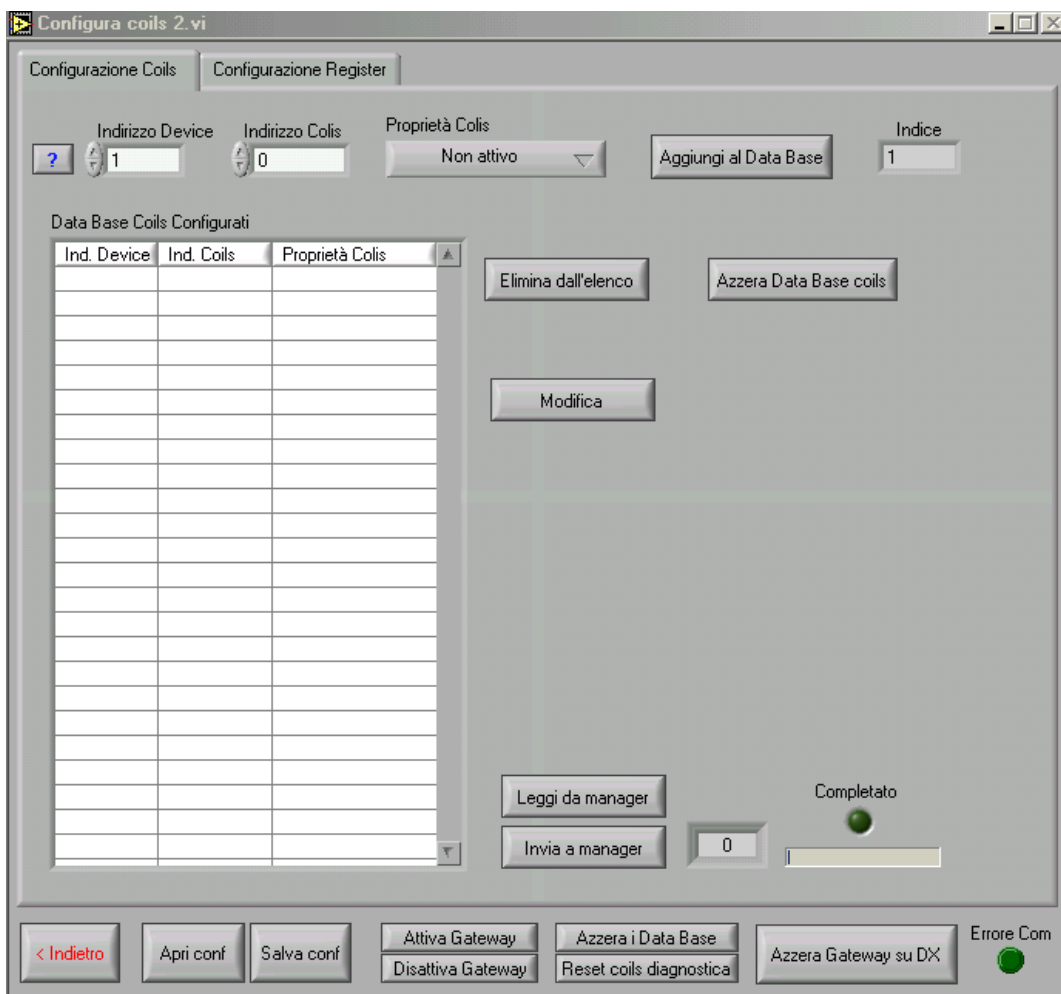

Activating the proper buttons, the variables compilation goes on. For each variable the following parameters are significant:

- delta2 controller address on the Inst Bus
- single Coil or Register MODBUS address
- single Coil or Register Read/Write properties

As compilation is finished you can send the list to DX ("**Send to Manager**") and/or save the list to a file on PC. The saved file can be opened later ("**Open file**") and loaded on DX.

Some other service buttons are available, to activate ("**ON**") or deactivate ("**OFF**") the Gateway, to reset the PC Databases ("**Database Reset**"), diagnostics Coils ("**DIAG Coils Reset**") and to reset the whole Gateway configuration on DX ("**DX Gateway Reset**").

MODBUS Terminal

From Main Menu page, an useful tool, the "**MODBUS Terminal**", can be activated.

After having selected the communication parameters and the protocol parameters, it is possible to send and receive messages and check the complete MODBUS strings. The low level of interface allows for an easy communication troubleshooting of the devices connected to the Inst Bus.

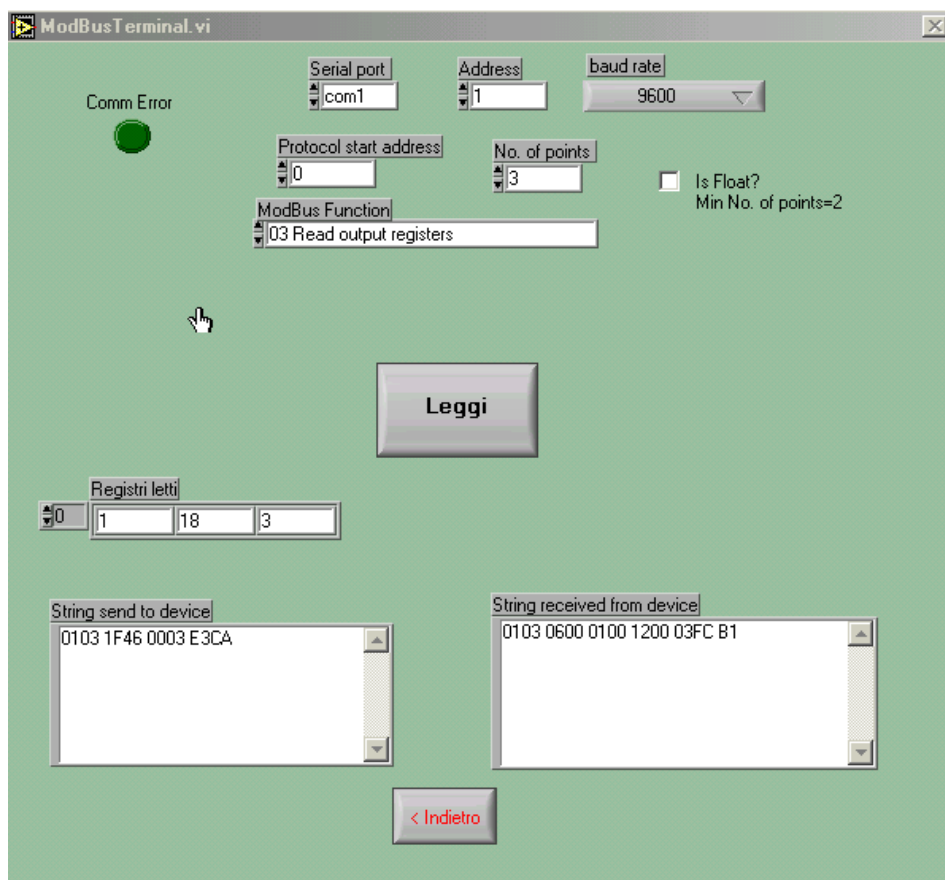

4. Diagnostics and Service

delta2 instruments Diagnostics

Status Registers

A diagnostic activity can be set for each controller present in the Manager list. The results are reported into the instrument's individual Status Register. The DX Database Registers from 8203 to 8234 contain the status of each device and the following error conditions:

Read Value	Error	Meaning
0	No error	The controller is correct and working
1	Check disabled	The diagnostic activity for the specified controller is disabled
2	Controller not present	No answer on the Inst Bus from the node address expected for the specified controller
3	Communication Error	Errors on Inst Bus communication activity with the specified controller
4	Wrong controller type	The stored controller data (product codes and options) doesn't match the real detected data from the Inst Bus
Write Value		Meaning
0		Controller Enabled
1		Controller Disabled

Table 7 - Diagnostic Read/Write Register for delta2 controllers

The diagnostics functions can be enabled/disabled for each single controller by writing the proper value to the related register. (see Table 7).

Diagnostic activity uses dedicated messages. These messages are interleaved with the normal communication traffic on the Inst Bus caused by Gateway function and/or by the Service Port in transparent mode.

The diagnostic activity execution time is configurable. There are three registers (8289, 8290, 8291) by which you can set the rate, the cycle time and the latency time.

Error Counter Register

An Error Counter Register is also available for each managed controller. The accounted errors come from communication activities on the Inst Bus and are updated in real time. The counters (Registers from 8303 to 8334) are cleared at Power Up or by writing "zero" to the registers.

5. Technical Data

General Specifications

	Port	Interface	Protocol	Speed	Notes
Communications	Inst Bus	RS485	MODBUS Master	1,2 .. 19,2 kb	Fixed frame 8N1
	Service	RS232/485	MODBUS Slave	1,2 .. 57,6 kb	
	Fieldbus	RS485	MODBUS Slave	1,2 .. 38,4 kb	Only one option present
		PROFIBUS	DP Slave	9,6 kb .. 12 Mb	
		Can 2.0b	CANOpen Slave	10 kb .. 1 Mb	
DeviceNet	10 kb .. 500 kb				
Inst Bus Network	Max. 32 Ascon delta2 (D1, D2, D3, D7, D8, D9) devices handled by <i>Manager</i> .				
Indicators	5 LEDs for Power On, Status, Bus Activity on Inst Bus and Fieldbus				
Power supply	24Vdc/ac –15%..+20%				
Isolation	Galvanic isolation: Power supply and Inst Bus, Service Port, Fieldbus Galvanic isolation: Inst Bus, Service Port and Fieldbus				
Enclosure	Phoenix ME 22,5 UT BUS/5 GN (code:2908744)				

Table 8 - delta2 DX General Specifications

Electrical Connections

On the instrument housing four terminal blocks are present, each with four screw terminals, and a pass through connector for power supply and the Inst Bus.

The terminals assignment is shown in the drawing below:

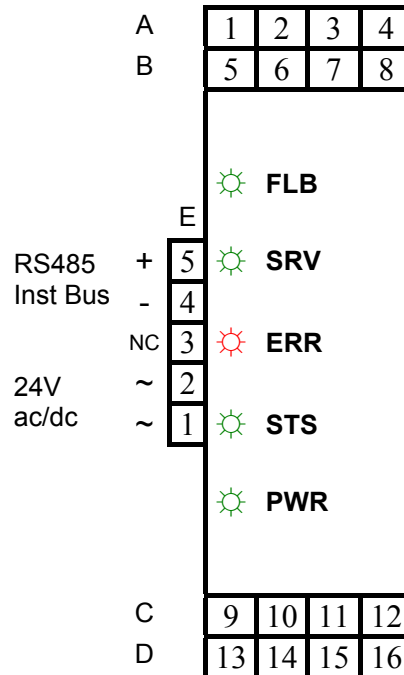

Figure 6 - DX Terminal Blocks assignment

Connector	Pin #	Assignment	Notes
Upper Front A	1 .. 4	RS485 Service Port.	The Service Port is available with two different electrical interface
Upper Front B	5 .. 8	RS232 Service Port (3-wire)	
Bottom Front C	9 .. 12	Inst Bus, interfaccia RS 485	Repetition of the Inst Bus
Bottom Front D	13 .. 16	Fieldbus Port	
Rear pass through E	1 .. 5	1, 2: 24Vac/dc Power Supply 3: Non Connected 4, 5: RS 485 Inst Bus	

Table 9 - DX Terminal Blocks assignment

Signalling LEDs

On the front side, 5 LEDs indicates the delta2 DX working status:

LED	Indication	Conditions
PWR (Power)	Indicates when the device is powered	On when the power is on
STS (Status)	Indicates the device's status	Off normal conditions Flashing during a Self-Learning phase
ERR (Error)	Indicates an error on the Inst Bus	Flashing when an error occurs in any controller Status Register
SRV (Service)	Indicates a communication activity on the Service Port	Flashing when DX send messages through Service Port
FLB (Fieldbus)	Indicates a communication activity on the Fieldbus Port	Flashing when DX send messages through Fieldbus Port

Table 10 - Signalling LEDs

Environmental Conditions

Operating Conditions		
Temperature	0°C .. +60°C	
Mounting	Vertical, free air	
Relative Humidity	5..95% (non condensing)	
Altitude	≤ 2000 m	
Vibrations (3 axes)	10..57Hz 0.0375mm amplitude 57..150Hz 0.5g constant acceleration	
Shock	15g, 11ms half sine (3 axes)	
Dimensions	99x22.5x114.5 mm	
Weight	150 g	
Safety regulations And CE marking	<ul style="list-style-type: none"> • EN 61010-1 • EN 50081-2 • EN 50082-2 • EN 61326 	Isolation: <ul style="list-style-type: none"> • Isolation class II (50Vrms) • installation category II • pollution degree 2

Storage and shipping Conditions	
Temperature	-20°C .. +70°C
Relative Humidity	5..95% (non condensing)
Atmospheric Pressure	≥ 70 kPa (700mbar) equivalent to 3000 m of altitude
Free falls	5 falls from 1m on concrete (with original packaging)

Table 11 - Environmental Conditions

Appendix A. MODBUS Maps

DX internal Database Map

Table 12 - Registers Map

Register	Identification	Meaning	R/W	Notes
8000	Operating Mode	Set the Service Port operating mode Allowable values are: 0: Transparent Mode 1: Off-Line Configuration 2: Gateway Configuration	R/W	At Power Up the Manager sets to Transparent Mode.
8001	Gateway Control	0: gateway disabled; 1: gateway enabled.	R/W	Enabling Gateway can be done while in Transparent Mode only. The enable command can be only accepted if the Gateway contains a valid configuration set. When the Gateway is enabled, the communication activity on Service Port will be forwarded to the Inst Bus, by interleaving service messages with the update messages from and to the Gateway Database.
8002	Self-Learning	0: Self-Learning not active 1: Self-Learning active	R/W	This command can be only accepted when in transparent Mode and Gateway function disabled. During a Self-Learning every messages between Service Port and Inst Bus are not allowed.
8003	Manufacturer's Code	ASCON ID decimal code: "600"	R	Type and model identification codes
8004	Controller ID	ASCII Code "DX"	R	
8005	Fiedbus Type	"M " MODBUS, "P " PROFIBUS, "CC" Can Canopen, "CD" Can Devicenet	R	
8006	Self-Learning starting address	Address of the first controller to be queried	R/W	Defines the address range within which the DX Manager try to detect delta2 controllers. Possible delta2 devices that are external to this range are not "visible" to the Manager functions.
8007	Self-Learning last address	Address of the last controller to be queried	R/W	
8008	Inst Bus Baud rate	Baud rate programmed on the Inst Bus	R	
8009	Manager Model	Ordering Code	R	
8010	N° of controllers	Number of Inst Bus delta2 controllers that are taken into consideration by Manager functions.	R/W	The Register value will be automatically updated at the end of Self-Learning procedure. It can be also written by a manual configuration operation.
8011	DX device selection address	DX Node Address (in the controllers registers range) through Service Port, when DX operates in Off-Line configuration mode.	R/W	

8012	Delta2 device #01 Node address	It's the Node address the delta2 Unit #01 answer back on the Inst Bus	R/W	The registers values will be updated at the end of a Self-Learning procedure. The registers can be programmed from outside too by means of a manual configuration operation The device numbering it's just to get a memory indexing. It hasn't any practical meaning.
8013	Delta2 device #01 Product Code 1	delta2 Unit #01 Register 122 value	R/W	
8014	Delta2 device #01 Product Code 2	delta2 Unit #01 Register 123 value	R/W	
8015	Delta2 device #01 Hardware Code	delta2 Unit #01 Register 151value	R/W	
8016	Delta2 device #01 Options	delta2 Unit #01 Register 152 value	R/W	
...	R/W	
8167	Delta2 device #32 Options	It's the Node address the delta2 Unit #32 answer back on the Inst Bus	R/W	
...	R/W	
8171	Opzioni Unità delta2 #32	delta2 Unit #32 Register 152 value	R/W	
8200	Manager Node Address	It's the Node address the DX manager answer back for internal memory map accesses. With "0" as Node Address the DX Manager replies at every node addresses.	R/W	
8201	Protocol	Setting of MODBUS (0), JBUS (1)	R/W	Valid for MODBUS Fieldbus type
8202	DX Status	In Reading the Register's LSB reports some info regarding the current operating status.	R	See table 14
		In Writing the Register's LSB manages some internal memory areas.	W	See table 15
8203	Device #01 Status	Delta2 Controller #01 diagnostics	R	In Reading the Register's LSB reports diagnostics info, according to the coding: 0. Status Ok 1. Manager Control Disabled 2. Device not present 3. Communication Error 4. Incorrect controller Type In Writing it is possibile to enable or disable the cyclic diagnostic check from DX Manager, by writing the values : 0. Enable 1. Disable
		Delta2 Controller #01 diagnostics enable command	W	
...	W	
8234	Device #32 Status	Delta2 Controller #32 diagnostics	R	
		Delta2 Controller #32 diagnostics enable command	W	
8289	Diagnostic rate	N° of wait cycles between two successive queries , in the absence of errors on the first one.	R/W	Diagnostics typical parameters settings
8290	Diagnostic cycle time	Diagnostic cycle execution time: 0 ÷ 3600 sec.	R/W	
8291	Diagnostics latency time	Latency time, in hundreths of second, between the interrogation of a controller and the successive controller.	R/W	

8300	Service Port Baud rate	0: 1200, 1: 2400, 2: 4800, 3: 9600, 4: 19200, 5: 38400, 6: 57600 Baud	R/W	Service Port typical parameters settings
8301	Service Port Address	It's the node Address to which DX Manager answer back for internal memory map accesses. Setting "0" as the address, the DX Manager will answer whichever the node address is.	R/W	
8302	Service Port Framing	0: 8N1, 1: 8E1, 2: 8O1, 3: 8N2, 4: 7N2, 5: 7E1, 6: 7O1, 7: 7N3	R/W	
8303	Device #01 Errors Counter	Inst Bus delta2 devices communication errors Counters.	R	The Registers update takes place only if the Manager's diagnostic check for the controller is enabled. The Counters reset is made at Power-Up or issuing the specific command.
...	...			
8334	Device #01 Errors Counter			
8999	DX FW Release			
9000	Coil #1 Node Id	Inst Bus device Address where the coil variable, associated to Coil #1 of Gateway area, resides.	R/W	Gateway Configuration
9001	Coil #1 Address	Coil variable address on Inst Bus device's memory map, to be associated to Gateway area Coil #1.	R/W	
9002	Coil #1 Properties	Variable update mode, according to the values: 0 = Non active variable. 1 = Read variable 2 = Write variable 3 = Read/Write variable	R/W	
...	R/W	
9381	Coil #128 Node Id	Inst Bus device Address where the coil variable, associated to Coil #128 of Gateway area, resides.	R/W	
9382	Coil #128 Address	Coil variable address on Inst Bus device's memory map, to be associated to Gateway area Coil #128.	R/W	
9383	Coil #128 Properties	Variable update mode, same as 9002 register.	R/W	
9400	Register #1 Node Id	Inst Bus device Address where the register variable, associated to Register #1 of Gateway area, resides.	R/W	Gateway Configuration
9401	Register #1 Address	Register variable address on Inst Bus device's memory map, to be associated to Gateway area Register #1.	R/W	
9402	Register #1 Properties	Variable update mode, same as 9002 register.	R/W	
...	...		R/W	
9997	Register #200 Node Id	Inst Bus device Address where the register variable, associated to Register #200 of Gateway area, resides.	R/W	
9998	Register #200 Address	Register variable address on Inst Bus device's memory map, to be associated to Gateway area Register #200.	R/W	

9999	Register #200 Properties	Variable update mode, same as 9002 register.	R/W	
10000	Gateway Node Address	Meaningful for PROFIBUS and MODBUS/JBUS	R/W	
10001	Baud rate	Meaningful for MODBUS only 0: 1200, 1: 2400, 2: 4800, 3: 9600, 4: 19200 Baud	R/W	Fieldbus Port communication parameters Framing parameters for MODBUS are fixed: 8, N, 1
10002	Protocol	Meaningful for MODBUS only 0: MODBUS 1: JBUS.	R/W	
10003	Gateway Error Trigger	The number of consecutive errors that sets the status Coil of a Gateway variable to "non consistent".	R/W	The errors refer to communication on the Inst Bus.
10004	Redirect Register Node Id	Inst Bus device's Node Address associated to the Redirect Register	R/W	Fieldbus MODBUS – Inst Bus device Point-to-Point channel parameters.
10005	Redirect Register address	Inst Bus device's Register Address	R/W	
10006	Redirect Register value	Inst Bus device's Register image	R/W	
20000	Reset	DX general Reset	R/W	Writing 21930 (55AAh) to this register causes a general Reset to the DX device.

Table 13 - Coils Map

Coil	Identification	Meaning	R/W	Notes
1000	Gateway Coil #1 Status	0: Updated and consistent data 1: Non consistent data	R/W	A Gateway area variable is meant to be in a consistent state if former communication activities on the Inst Bus (devices Read and Write operations) have been correctly executed. Every updating error (from and to the Inst Bus) induces the status coil to a "non consistent" value (1). Writing 0 to the status coil will reset the coil.
...	...			
1127	Gateway Coil #128 Status			
1128	Gateway Register #1 Status			
...	...			
1327	Gateway Register #200 Status			
1328	Gateway Coil area Status	Logic OR of all Coils area statuses	R/W	
1329	Gateway Registers area Status	Logic OR of all Registers area statuses	R/W	
1330	Gateway memory Status	Logic OR of all Gateway memory statuses	R/W	

Bit							
7	6	5	4	3	2	1	0
Gateway active	Self-Learning in progress	Operating Modes: 0 0 = Transparent Mode 0 1 = Off-Line Mode 1 0 = Gateway Configuration					Inst Bus Error

Table 14 - DX Status Register Read Mask (Register 8202)

Bit							
7	6	5	4	3	2	1	0
Save data (flash mem)	Reset Gateway Database	Reset Manager Database					Reset error counters

Table 15 - DX Status Register Write Mask (Register 8202)

Functions

A subset of MODBUS/JBUS functions is implemented on ASCON delta2 series of controllers:

Code	Name	Function
01	Read Coil Status	Read the status (ON OFF) of binary logic variables.
02	Read Input Status	This function is quite the same as the previous one.
03	Read Holding Registers	Read the value of 16 bit Registers (words) containing numeric variables.
04	Read Input Registers	This function is quite the same as the previous one.
05	Force Single Coil	Force the status of a single binary logic variable (ON OFF)
06	Preset Single Register	Set up the value of a single 16 bit Register.
07	Read Status	Read in a compact way the status of a definite 8 bit set.
08	Diagnostics	Check the Master-Slave communication. The only enabled sub function is "Query" (code 00h). This function is only available for delta2 controllers D1, D3, D7.
15	Force Multiple Coils	Force the status of each binary variable in a block of variables in a row.
16	Preset Multiple Registers	Set up the value of each register in a block of 16 bit Registers in a row.

Table 16 - delta2 controllers MODBUS functions

NOTE

Putting this into practice, functions 01 and 02 are quite the same and interchangeable, as well as functions 03 and 04. Functions 05 and 15 are expected to be present but, in normal conditions, it is not allowed to assign a status to any bit, then, in practice, these functions should be avoided. Function 16 allows for a maximum of 8 words block.

Exception Codes

Standard MODBUS/JBUS schedules eight different exception codes. The actual implementation takes into consideration only four:

Code	Name	Meaning
01	ILLEGAL FUNCTION	The received function code doesn't match an allowed function of the addressed slave. In case of Diagnostics (08) function, it may indicate a non implemented sub function.
02	ILLEGAL DATA ADDRESS	The address referenced in the data field is not an allowed address for the questioned slave.
03	ILLEGAL DATA VALUE	The value to be assigned (in the data field) is out of range for the current address.
07	NAK - NEGATIVE ACKNOWLEDGEMENT	The function cannot be executed in the current operating conditions or an attempt to write to a read-only variable has been made.

Table 17 - Exception Codes

Appendix B. Suggestions and Examples

RS485 network topology

MODBUS on RS485 networks uses a linear type of Bus. See figure 7.

It is mandatory to insert termination resistances at both extremes of a trunk. The total length L of node derivations, from the trunk or from T junctions, must be maximum 20 meters, depending on the Baud rate. Each derivation can support one or more (N) nodes. In the latter case:

$$L = 40/N \text{ meters (max).}$$

The network total cable length, including derivations, depends on the Baud rate and on conductor type. The maximum network length is 1000 meters (at 9600 Baud).

The Bus conductors can be parallel, twisted and/or shielded, depending on EMC requirements for a good functioning. If a shield is provided it is necessary to propagate it electrically through the nodes. The shield conductor should be connected to a functional earth at one of trunk line ends.

In order to minimize reflections, the cable topology should be similar to a linear path as much as possible.

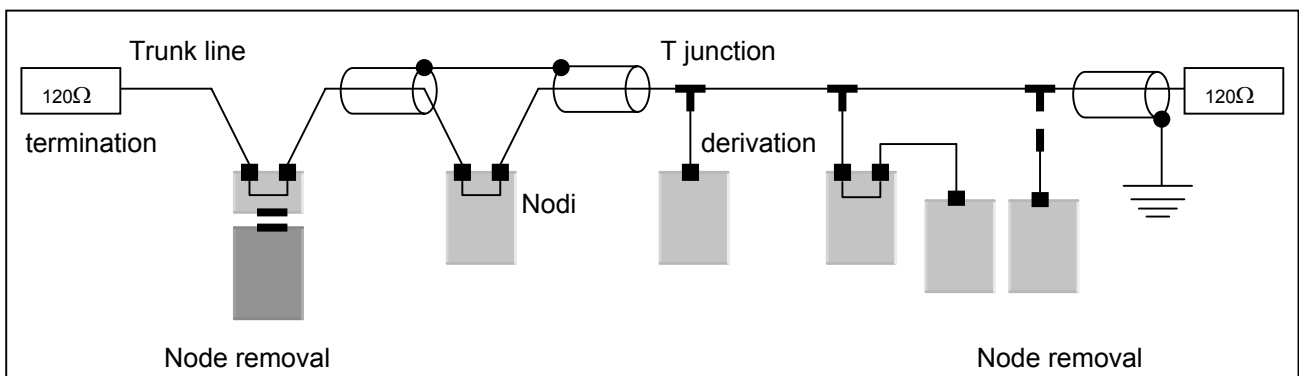

Figure 7 - RS485 MODBUS network topology

Trunk line

If derivations are not expected, node to node connections are made through the trunk line. In case of derivation, the connection between nodes and trunk line will be done by means of T junctions. The maximum number of nodes in a MODBUS network is limited to 32. The maximum length of a trunk cable depends on Baud rate and cable type. The distance can be increased by using signal repeaters.

Node derivation cable

The derivation cable is the mean to connect a node to trunk line.

The connection is made through a special three way connector, the so called T junction.

The typical derivation cable is smaller and more flexible than the cable used for trunk line. Special attention should be taken to keep the length of derivation cable as short as possible, especially at high Baud rates. Allowed maximum: 20 meters.

Termination resistances

MODBUS on RS485 requires the installation of a termination resistance at both end of trunk line. The typical required resistance is 120 Ohm metal layer 0.25W rated.

PROFIBUS on RS485 networks uses a linear type of Bus. See figure 8.

It is mandatory to insert termination resistances at both extremes of a trunk. Nodes derivations, from trunk line or by T junction are not recommended.

The network total cable length depends on the Baud rate and on conductor type. The segment max length is 1200m (from 9.6 to 93.75 kbit/s). The distance can be increased by using signal repeaters.

Data rate (kbit/s)	9.6 - 93.75	187.5	500	1500	3000 - 12000
Segment length (m)	1200	1000	400	200	100

The Bus conductors can be parallel, twisted and/or shielded, depending on EMC requirements for a good functioning. If a shield is provided it is necessary to propagate it electrically through the nodes. The shield conductor should be connected to a functional earth at one of trunk line ends.

In order to minimize reflections, the cable topology should be similar to a linear path as much as possible.

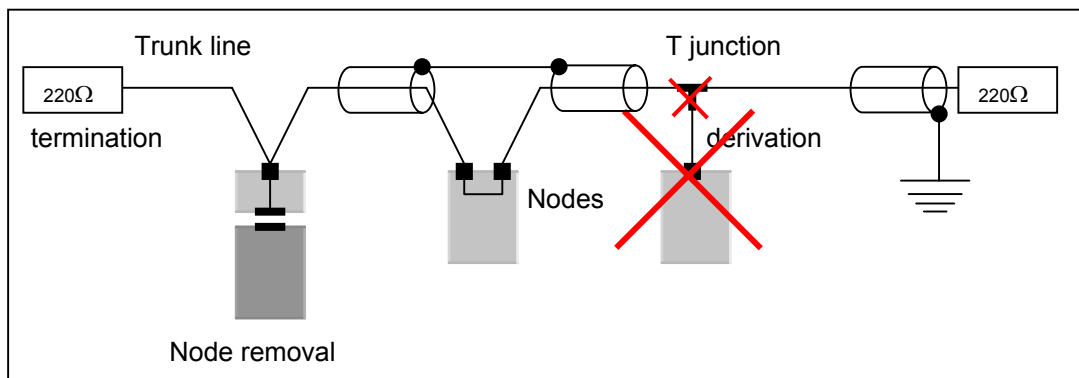

Figure 8 - PROFIBUS network topology

Trunk line

Node to node connections are made through the trunk line. The maximum number of nodes in a PROFIBUS network is limited to 32, including repeaters. This number can be increased up to 126 by using signal repeaters, with the limit of not more than 4 repeaters between every two nodes, wherever they are in the network. Using repeaters increase the maximum distance too:

$$L_{MAX} = (\text{repeaters number} + 1) \times \text{segment length}$$

Termination resistances

PROFIBUS on RS485 requires the installation of a termination resistance at both end of trunk line. The typical required resistance is 220 Ohm metal layer 0.25W rated.

NOTE If the delta2 DX – PB device will be placed as the final node of the network the termination resistance must be connected between the two PROFIBUS signals A and B, terminals 14 and 15.

Appendix C. Definitions, Symbols and Conversion Tables

Measurement	English to metric units		Metric to English units	
Length	1 in	25.4 mm	1 mm	0.039 in
	1 ft	30.48 cm	1 cm	0.328 ft
	1 yd	0.914 m	1 m	3.281 yd
	1 mi	1.609 km	1 km	0.621 mi
Temperature	$^{\circ}\text{C} = \frac{5}{9} (^{\circ}\text{F} - 32)$		$^{\circ}\text{F} = \frac{9}{5} ^{\circ}\text{C} + 32$	
Power	1 hp = 0.746 kW		1 kW = 1.34hp	

Table 18 - English Units - Metric Units Conversion Table

°C	-25	-20	-15	-10	-5	0	5	10	15	20	25	30	35	40	45	50	55	60	65	70
°F	-13	-4	5	14	23	32	41	50	59	68	77	86	95	104	113	122	131	140	149	158

Table 19 - Temperature Conversion Table

mm²	0.13	0.22	0.25	0.5	0.75	1	1.5	2.5	4	6	10	16	25	35	50
AWG	26	24	24	20	18	18	16	14	12	10	8	6	4	2	1/0

Table 20 - Conductor Cross Section Conversion Table: mm² - AWG (American Wire Gauge)

Electrical Connections

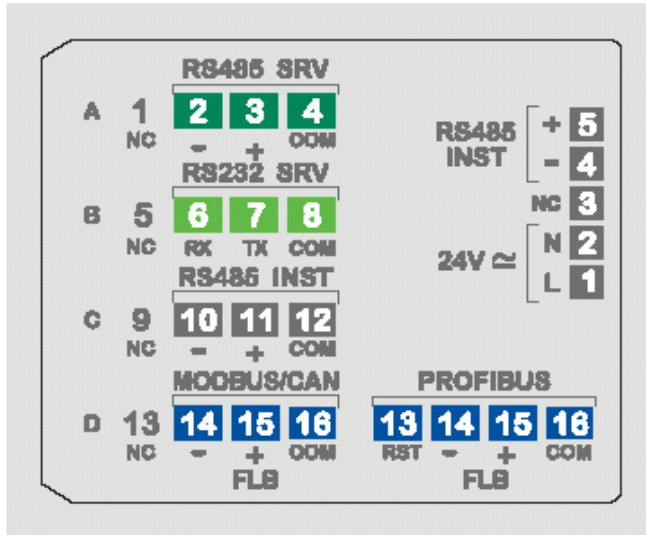

ASCON spa
 Via Falzarego, 9/11
 Bollate (Milano)
 I-20021 Italy
 Tel. +39 02 333 371
 Fax +39 02 350 4243
<http://www.ascon.it>
support@ascon.it

Ordering Codes

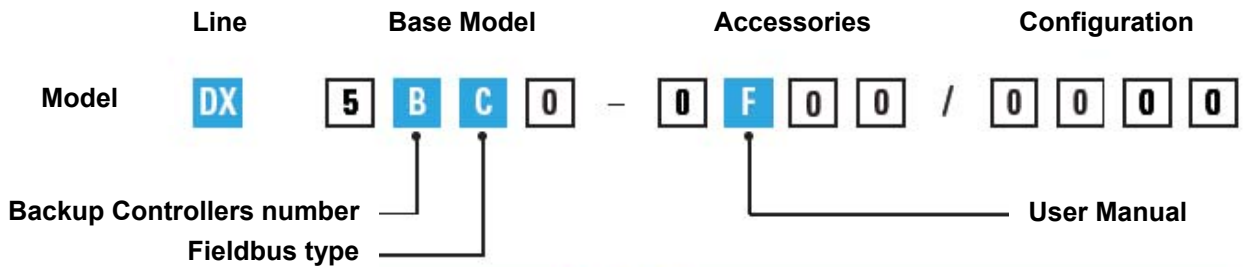

Backup Controllers Number	B
0 (RS232 ↔ 2 x RS485 converter)	0
4	1
8	2
16	3
32	4

User Manual	F
Italian - English	0
French - English	1
German - English	2
Spanish - English	3

Fieldbus Type	C
No option	0
CANopen	3
RS485 MODBUS/JBUS	5
PROFIBUS DP slave	7

If not otherwise specified DX device will be shipped in standard version Model DX 5100-0000