

D9 line Installation manual

Table of contents

- General description
- Model code
- Electric safety
- Installation kit
- Installation
- Remove/insert the module in its housing
- Electrical connections

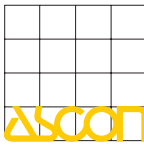

ASCONE spa
ISO 9001
Certified

ASCONE spa
Via Falzarego 9/11
20021 Bollate
(Milano) Italy
Tel. +39 02 333 371
Fax +39 02 350 4243
<http://www.ascone.it>
e-mail support@ascone.it

DIN rail mounting 2 channels data acquisition module



D9 line 
Installation manual • M.I. D9-1/04.10 • Cod. J30-658-1AD9 IE



General description

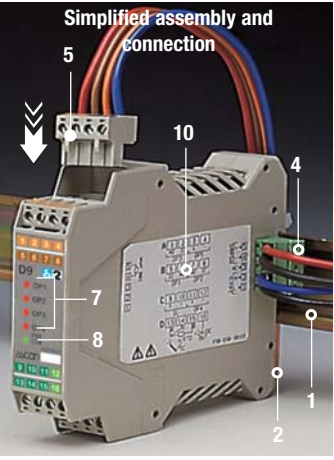

- 1 DIN-rail, EN60022
- 2 Spring loaded slide for rail fastening
- 3 Side connector, build-in, to connect one instrument to another (up to 31)
- 4 5-pole male connector, with screw terminals, for power supply and serial communications bus
- 5 Four quick polarised connectors with 4 screw terminals for I/O

- 6 Female connector, with termination resistor for serial communications
- 7 Four Output status leds (red)
- 8 Green Status led:
 - ON: power on
 - flashing: serial communications in progress
- 9 Couple of connector protections
- 10 Wiring label
- 11 Model identification label

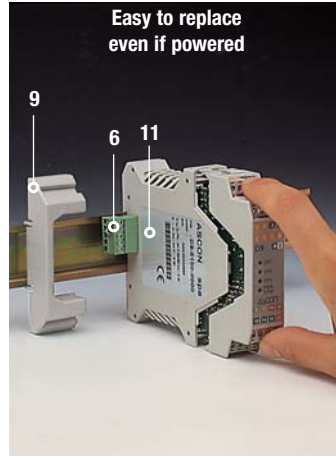
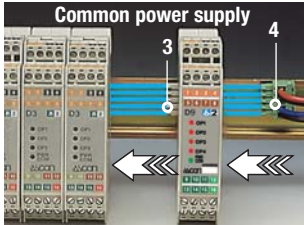

Model code

Mod. **D9** **5BC0** - **0F00**
Line Basic Accessories

The product code indicates the specific hardware configuration of the instrument, that can be modified by specialized engineers only.

Line **D9**

OP1-OP2 outputs	B
Relay - Relay	1
Relay - SSR drive	2
SSR drive - SSR drive	3
SSR - SSR	4
SSR - SSR drive	5

Serial communications	C
CanBus	3
RS485 Modbus/Jbus SLAVE	5

User manual	F
Italian/English (std)	0
French/English	1
German/English	2
Spanish/English	3

Notes on electric safety and electromagnetic compatibility





Please, read carefully these instructions before proceeding with the installation of the instrument

Class II instrument, rear panel mounting.
This instrument has been designed in compliance with:
Regulations on electrical apparatus:
according to regulations on the essential protection requirements in electrical apparatus EN 61010-1
Regulations on Electromagnetic Compatibility:
according to:
- Regulations on RF emissions:
EN61000-6-4 industrial environments;
- Regulation on RF immunity:
EN61000-6-2 industrial equipment and system.

It is important to understand that it's responsibility of the installer to ensure the compliance of the regulations on safety requirements and EMC.
This controller has no user serviceable parts and requires special equipment and specialised engineers. Therefore, a repair can be hardly carried on directly by the user. For this purpose, the manufacturer provides technical assistance and the repair service for its Customers.
Please, contact your nearest Agent for further information.
All the information and warnings about safety and electromagnetic compatibility are marked with the  sign, at the side of the note.

Installation kit

Each set of interconnected controllers requires one model **AD3-KIT/BA.RT.PC.CD** kit:

- Power supply and serial comm.s connector code AD3/BA 
- Couple of connectors protections code AD3/PC 
- Connector with termination resistor for serial communications code AD3/RT 
- CD Rom with configuration software tool code AD3/CD 

Installation

Dimensions

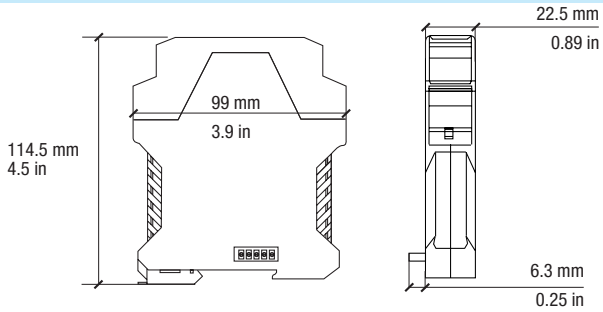

Environmental condition		CE	Suggestion
Operating conditions	Temperature 0...50 °C		
	Relative humidity 5...95% Rh non-condensing		
Special conditions	Temperature > 50 °C		Use forced ventilation
	> 95% RH		Warm up
	Conducting atmosphere		Use filter
Forbidden condition	Corrosive atmosphere		
	Explosive atmosphere		

Mounting on DIN rail (EN60022)

Mounting

- Clip the upper part of the instrument on the rail;
- Rotate the instrument downwards until the click.

When 2 or more instruments are installed on the same DIN rail, connect the communications/ power bus sliding the instruments side by side as explained in the following paragraphs.

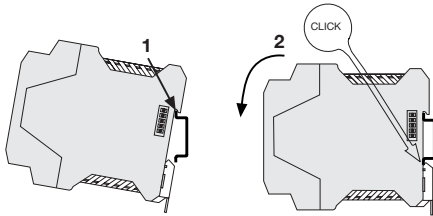

Disassembly

Switch the instrument off

When 2 or more instruments are installed on the same DIN rail, disconnect the communications/power bus separating the selected instrument from the others;

- Lower the spring slide by inserting a flat-blade screwdriver as indicated;
- Turn and lift the instrument upwards.

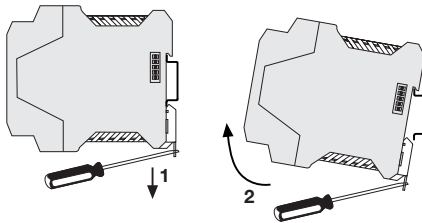

Mounting several instruments (up to 31) side by side

- After the mounting of instruments on the rail, put them side by side so that the male side connector fits into the corresponding female connector;
- After mounting all the instruments side by side insert the female 5-pole connector with the termination resistor of the serial communications into the corresponding male connector;
- Wire the 5-pole male power supply and serial communications connector and insert it in the corresponding female connector;
- When assembled insert the connectors protection on both sides.

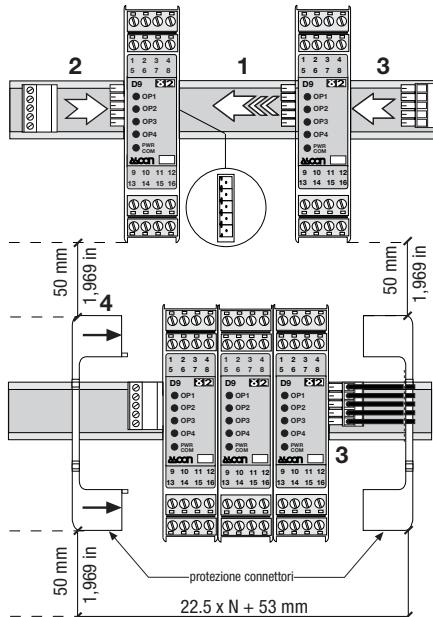

Remove/insert the module from/in its housing

How to remove the module from the housing

- Insert the blade of a negative screwdriver under the I/O polarised connectors;
- Moving the screwdriver as indicated, unplug the connector from the module;
- Remove the connector and repeat these steps in order to unplug all the external connections;
- With the blade of the screwdriver, press the two slots (at the top and bottom of the module) in order to free the I/O module from the housing;
- Firmly grip the front panel in the terminal block area and pull the module outside the housing.

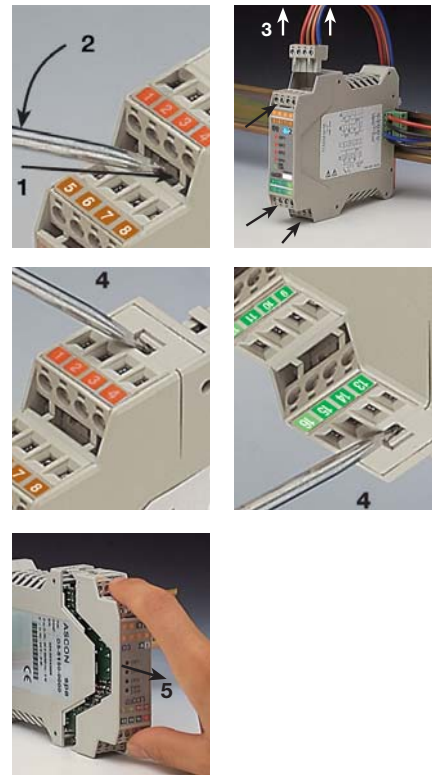

How to re-insert the I/O module in the housing

- In order to correctly re-insert the module in its housing, invert the previous extracting sequence, paying particular attention in inserting the printed circuit board in the slots present at the top and bottom of the case.

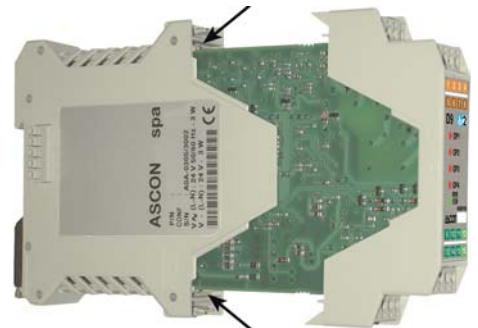

Terminal connectors and plugs

4 terminal connectors

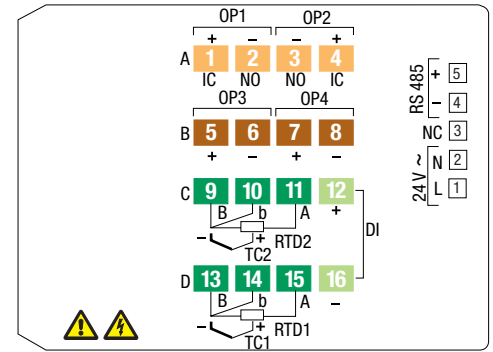
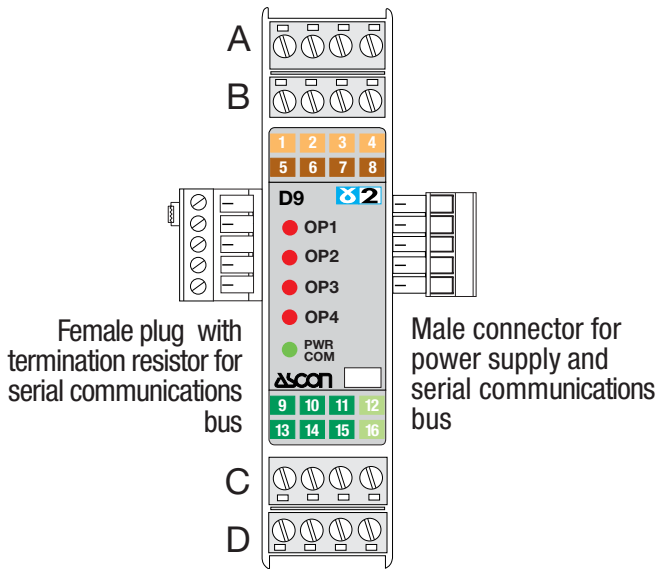

Features	Terminal connectors A-B-C-D	Power supply and communications connector
Flexible cable section:	0.2...2.5 mm ² (AWG24...AWG12)	0.08...1.5 mm ² (AWG28...AWG16)
Stripped wire	7 mm - 0.28 in	7 mm - 0.28 in
Negative screwdriver	0.6 x 3.5 mm	0.4 x 2.5 mm
Tightening torque	0.5...0.6 Nm	0.4...0.5 Nm

Input

Isolated PV inputs: L-J-K-S-R-T-B-N-E-W thermocouple type

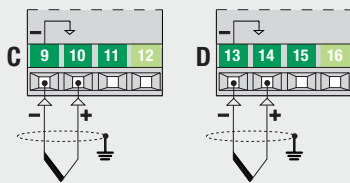

Line 150Ω max.

- Respect the polarity shown;
- To extend the connection, use always compensation cable of the correct type for the thermocouple used;
- When present the shield must be connected to a proper earth (at only one end).

Isolated PV inputs: for DC input mA, mV

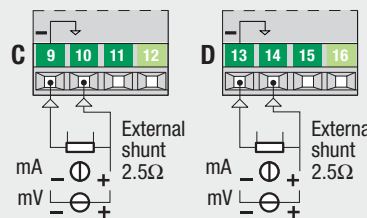

- Respect the polarity shown.

Isolated PV inputs: Pt100 resistance thermometer

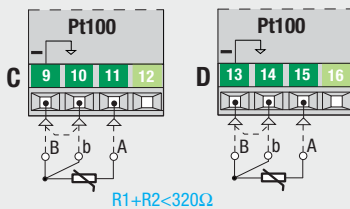

- If a 3 wires system is used, always use cables of the same section (1mm² min.)(max. resistance 20Ω/line);
 - When using a 2 wires system, always use cables of the same section (1.5mm² min.) and put a jumper between terminals 13 and 14;
- ⚠ When the distance between the instrument and the sensor is 15 m, the use of a 1.5 mm² section cable produces a 1°C (1.8°F) measure error.

Isolated PV inputs: Pt100 resistance thermometer for ΔT measures (2 x Pt100) special

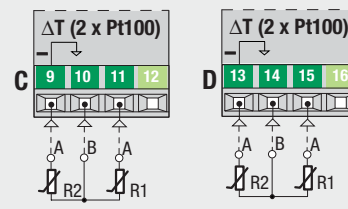

- ⚠ When the distance between the instrument and the sensor is 15 m, the use of a 1.5 mm² section cable produces a 1°C (1.8°F) measure error.

Digital input for external commands

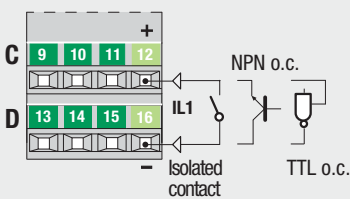

- **ON**
The input is active when the logic state is ON, corresponding to the contact closed;
- **OFF**
The input is inactive when the logic state is OFF, corresponding to the contact open

Digital inputs

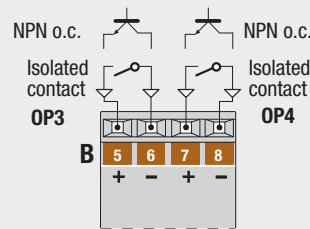

- ⚠ When terminals 5, 6 and 7, 8 are not configured as OP3 and OP4 outputs, they can be used as voltage or isolated contact inputs.



Precautions



All the wiring must comply with the local regulations.

The supply wiring should be routed away from the power cables.

Avoid to use electromagnetic contactors, power relays and high power motors nearby.

Avoid power units nearby, especially if controlled in phase angle.

Keep the input low voltage sensor wires away from the power lines and the output cables.

If this is not achievable, use shielded cables on the sensor input, with one end of the shield connected to earth.

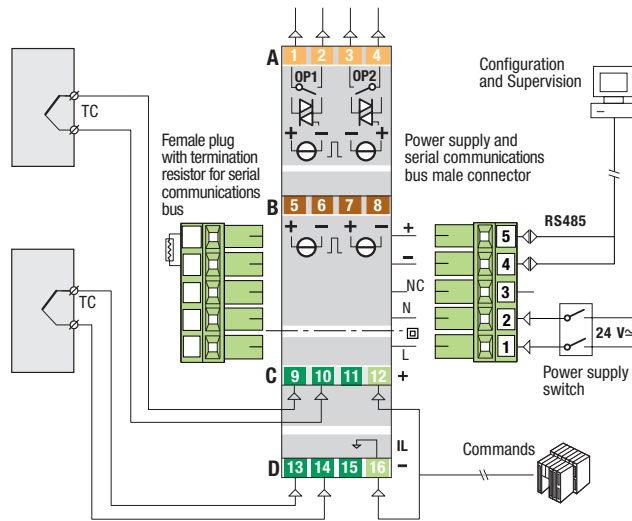

Notes



- 1 Make sure that the power supply voltage is the same indicated on the instrument.
- 2 Switch on the power supply only after all the electrical connections have been completed.
- 3 In accordance with the safety regulations, the power supply switch shall bring the identification of the relevant instrument. The power supply switch shall be easily accessible from the operator.
- 4 The instrument is PTC protected. In case of failure it is suggested to return the instrument to the manufacturer for repair.
- 5 To protect the instrument internal circuits use:
 - 2 AT fuses for relay outputs with 250 Vac load
 - 4 AT fuses for relay outputs with 120 Vac load
 - 1 A~T for SSR outputs.
- 6 Relay contacts are already protected with varistors. **Only in case of 24 Vac inductive loads, use model A51-065-30D7 varistors (on request).**

OP1 - OP2 - OP3 - OP4 outputs

Alarms on OP1 and OP2
Relay (SSR or SSR drive)

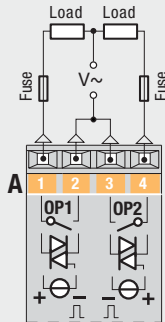

Alarms on OP3 and OP4
SSR drive

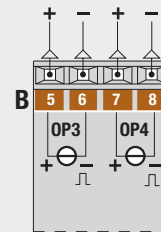

⚠ When terminals 5, 6 and 7, 8 are not configured as OP3 and OP4 outputs, they can be used as voltage or isolated contact inputs

OP1-OP2-OP3-OP4 output characteristics

Output	Type	For resistive load or auxiliary circuit breaker
OP1 - OP2	Relay	SPST Relay N.O., 2A/250 Vca 4A/120Vac External fuse 2A~T at 250Vac External fuse 4A~T at 120Vac
OP1 - OP2	SSR	1A/250 Vac External fuse 1A~T
OP1 - OP2	SSR drive	Not isolated: 0...5 Vdc, ±20% 30 mA max.
OP3 - OP4	SSR drive	Not isolated: 0...5 Vdc, ±20% 30 mA max.

Power supply bus and serial communication RS485

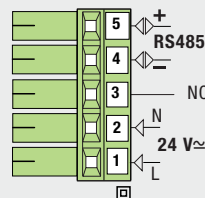

Power supply: Switching type with double insulation with incorporated PTC (resettable fuse).
 Rated voltage: 24 Vac (-25...+12%) 50/60 Hz;
 24 Vdc (-15...+25%).
 Power consumption: 3 W max.
 Protection: PTC protected.
Serial communications: Passive and galvanically isolated interface 500 Vac/1 min.
 Conforms to standard EIA RS 485, Modbus/Jbus protocol.