

DIN rail mounting dual loop controller/analogue acquisition module delta**due**[®] series **D2 line**

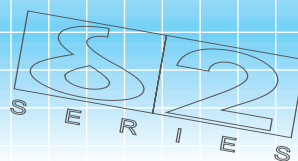

Two loops in the space of one

A common bus for serial power supply and communications, total withdrawability, ease of replacement even with the power supply on, digital inputs for remote commands, the option of acquiring or controlling two analogue variables makes the delta**due**[®] D2 line a powerful and flexible instrument, suitable for solving the most diverse problems of field signal management. Together with the DX module, it can be used in PROFIBUS DP[®] and DeviceNet[®] networks, with the automatic reconfiguration option (hot swapping).

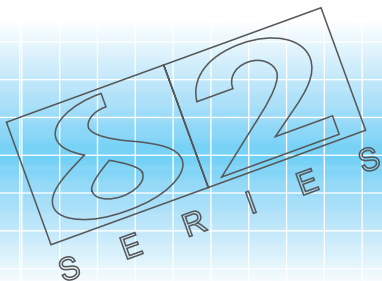
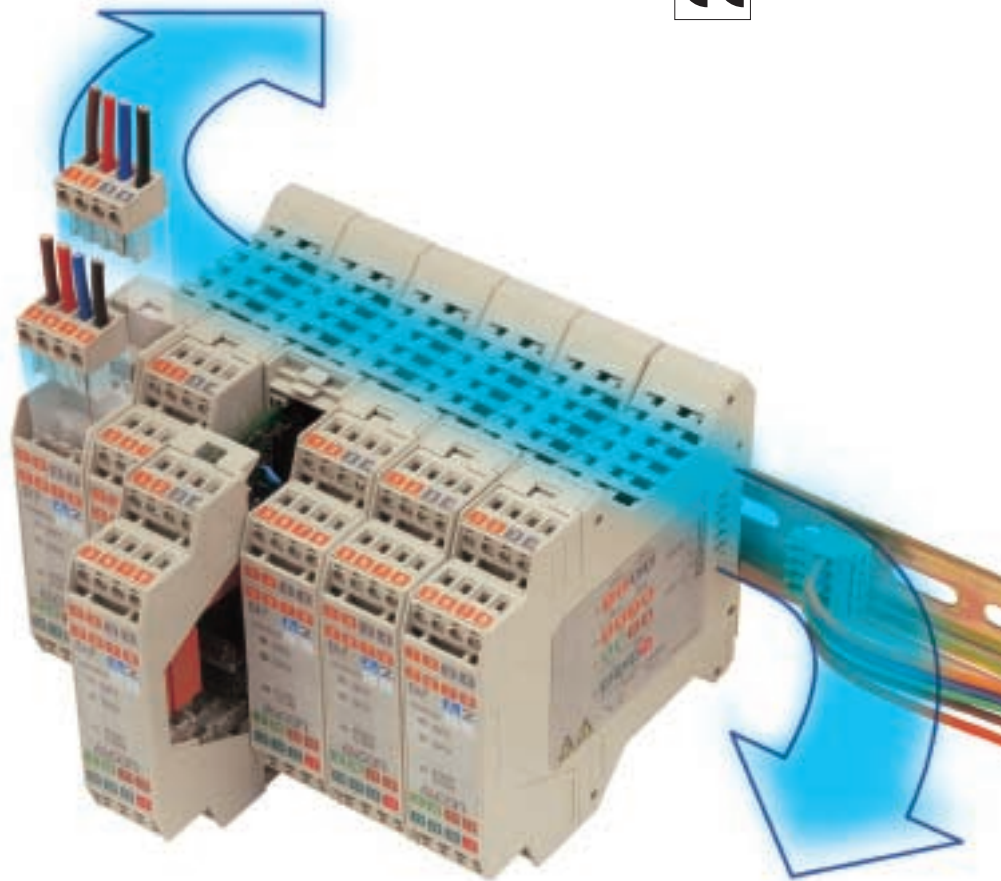

E

ISO 9001 certified

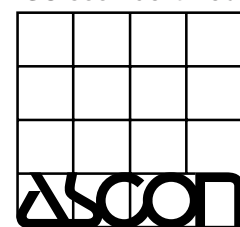

Advantages and peculiarities

Keeping costs low



Modular construction and compact dimensions:
 - Quick mounting on DIN rail;
 - Possibility of prewiring;
 - Common bus for power supply and serial communications.



- Polarised connectors;
 - Coloured Terminal identification.

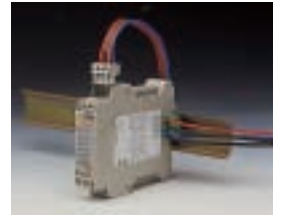

High integration

- On-machine or rear panel mounting
- Remote/centralised control;
- RS485/CanBus;
- PROFIBUS DP, DeviceNet (with DX module).



- Withdrawable;
- Easy replacement without switching off the power supply;
- Hot swapping, automatic configuration of the new or replaced modules (with DX module).



Easy maintenance

Typical applications

Local control with operator panel OP30

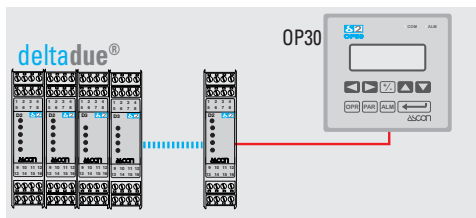

Distributed control with PLC with dedicated modules for critical loops

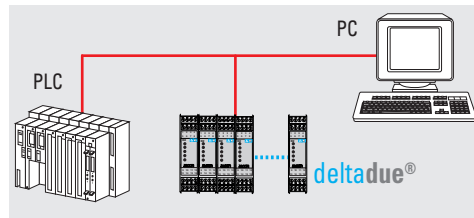

Distributed control with PC supervision

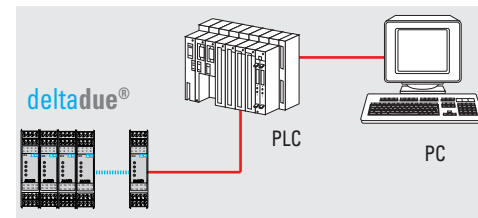

Resources

Main universal inputs

PV1: 12 TC, Pt100, ΔT, mA V, Custom

PV2: 12 TC, Pt100, ΔT, mA V, Custom

Digital input for external commands

IL1

Digital outputs [1]

OP1, OP2, OP3, OP4

Digital inputs [2]

Modbus RS485
Parameterisation
Supervision

Setpoint

LOC

IL1 connected functions

MEM, HOLD PV, ACK

Available functions

Not

Fuzzy tuning with automatic selection

One shot Auto tuning, One shot Natural Frequency

Operating modes

		Control	Alarms	
PV1	0 Acquisition only		OP1	OP2
	1 Single action	OP1	OP2	
	2 Single action	OP2	OP1	
PV2	3 Acquisition only			OP3 OP4
	4 Single action	OP3		OP4
	5 Single action	OP4		OP3
PV1	6 Single action	OP1	OP2	OP3
PV2	7 Single action	OP4		

Notes: 1. Each output (OP1...OP4) can freely be associated with one of the two inputs (PV1 or PV2).
 2. When outputs OP3 and OP4 are not used as such, they can be used as voltage free or voltage digital inputs.

Technical data

Features at env. 25°C	Description		
Total configurability	By means of the configuration tool it is possible to select: - type of input - the type of control input - type of output - type and functionality of the alarms - type of Setpoint - control parameter values		
PV1 and PV2 inputs	Common characteristics	A/D converter with resolution of 50,000 points Update measurement time: 0.2 s Sampling time: 0.5 s Input bias: -60...+60 digit Input filter: 1...30 s OFF = 0	
	Accuracy	0.25% ±1 digit (for temperature sensor) 0.1% ±1 digit (for mA and mV)	Between 100...240Vac the error is minimal
	Resistance thermometer (for ΔT: R1+R2 dmust be <320Ω)	Pt100Ω at 0°C (IEC 751) °C/°F selectable	2 or 3 wires connection Burnout (with any combination)
	Thermocouple	L,J,T,K,S,R,B,N,E,W3,W5 (IEC 584) °C/°F selectable	Internal cold junction compensation with NTC Error 1...20°C ±0,5°C ±0.5°C Burnout
	DC input (current)	0/4...20mA, 2.5Ω ext. shunt Rj >10MΩ	Burnout. Engineering inputs, decimal point position configurable low range: -999...9999 high range: -999...9999 (min range: 100 digits)
	DC input (voltage)	10...50mV, 0...50mV Rj >10MΩ	Input drift: <0.1%/20°C Env. Temp. <5μV/10Ω Wire Res.
	Mutual isolation	Isolation voltage 500V	
Digital input	Closing the external contact allows:	Auto/Man mode change, switching between 2 stored setpoints, measure hold, alarms acknowledge, outputs lock	
Operating mode	2 acquisition channels, 2 single action loops PID or ON/OFF with 1, 2, 3 or 4 alarms		
Control mode	Algorithm	PID with overshoot control or ON/ OFF	
	Proportional band (P)	0.5...999.9%	OFF = 0
	Integral time (I)	0.1...100.0 min	
	Derivative time (D)	0.01...10.00 min	
	Error dead band	0.1...10.0 digit	
	Overshoot control	0.01...1.00	
	Manua reset	0.0...100.0%	Single action PID algorithm
	Cycle time (time proportional only)	1...200s	
	Control output high limit	10.0...100.0%	
	Soft start output value	0.1...100.0%	
Output safety value	0.0...100.0%	ON/OFF algorithm	
Control output hysteresis	0.1...10.0%		

Fuzzy-Tuning

Two methods of tuning are available:

- **Auto-Tuning "one shot"**
- **Natural frequency "one shot"**

The **Fuzzy-Tuning** automatically selects one of the two methods which assures the best result for each condition.

Auto-Tuning method best works on the step response basis.

When activated, if a deviation exists between the Setpoint and process variable larger than 5% of scale range, the controller modifies the output value. Then, in a short time, it calculates the PID parameters and the new algorithm is operational immediately.

The main advantages of this method are fast calculation and quick implementation.

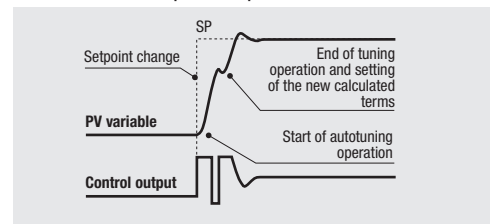

The **Natural frequency** method best works when the process variable is very near to the Setpoint. When activated, it causes a process oscillation around the Setpoint value in order to calculate the optimal PID parameters.

The main advantage of this method is the better definition of PID parameters.

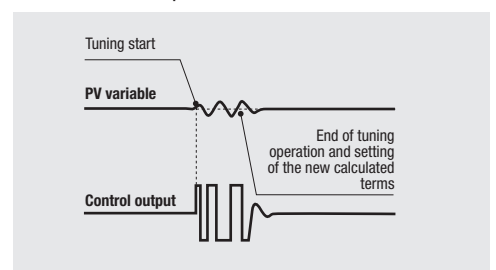

Technical data

Features at 25°C Env. Temp.	Description		
OP1-OP2 outputs	SPST relay NO, 2A/250Vac (4A/110 Vac) for resistive load SSR, 1A/250Vac for resistive load SSR drive: 0/5Vdc, ±10% 30 mA max. <u>To meet the double isolation requirements, OP1 and OP2 must have the same load type</u>		
OP3-OP4 outputs	Non isolated logic: 0/5Vdc, ±10% 30 mA max.		
Outputs functions	For all the outputs the inversion function (NOT) is available		
AL1 - AL2 - AL3 - AL4 alarms	Hysteresis	0.1...10.0%	
	Action	Active high	Action type
		Active low	Deviation threshold ±range Band threshold 0...range Absolute threshold whole range
		Special functions	Sensor break, Loop break Alarm acknowledge (latching), activation inhibit (blocking)
Setpoint (for each loop)	Local	Up and down ramps 0.1...999.9 digit/min (OFF=0)	
	Local plus 2 stored	Low limit: from low range to high limit High limit: from low limit to high range	
Fuzzy-Tuning one shot (1 loop at a time)	The controller automatically selects the best method according to the process conditions	One shot Auto Tuning One shot Natural Frequency	
Auto/Man station	Standard with bumpless function, Switched by digital input or serial communications		
Serial communications	RS 485 isolated, Modbus/Jbus protocol, 1,200, 2,400, 4,800, 9,600 bit/s 2 wires		
Operational safety	Measure input	Detection of out of range, or input problems causes automatic activation of the safety strategies	
	Control output	Safety value: -100...100%	
	Parameters	Parameters and configuration data are stored in a non volatile memory for an unlimited time	
	Outputs lock		
General characteristics	Power supply (PTC protected)	24Vac (-20...+12%) 50/60Hz and 24Vdc (-15...+25%)	Power consumption 3 W max.
	Safety	EN61010-1 (IEC1010-1) installation class 2 (2,5kV), pollution class 2, instrument class II	
	Electromagnetic compatibility	Compliance to the CE standards	
	Protection	Terminal blocks IP20	
Dimensions	Pitch: 22.5 mm - height: 99 mm - depth 114.5 mm		

Alarms

Four thresholds can be addressed to the two relay outputs. For each alarm can be configured:

A - Function

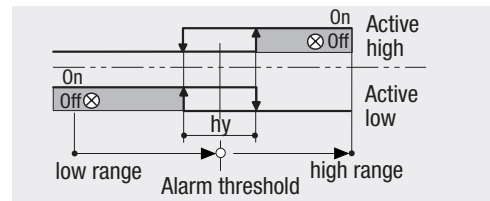

B - Functionality of the alarm acknowledge

Alarm acknowledge function

The alarm status remains until the acknowledge signal arrives through the serial communications port or the digital input. After this operation alarm status disappears only when the alarm condition is no longer present.

Start-up disabling

Ramp down

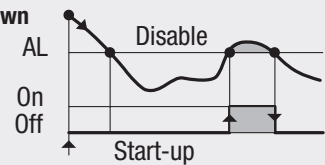

Ramp up

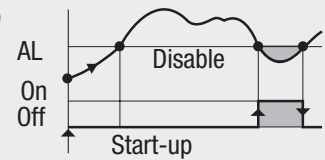

Digital input

During the configuration procedure, to the IL digital input can be connected one of the following functions:

- Measure Hold: PV1, PV2 or PV1 and PV2.
- Auto/Man mode change: PV1, PV2 or PV1 and PV2.
- Recall of the 2nd stored Setpoint: 2° setpoint LOOP1, 2° setpoint LOOP2 or 2° setpoint LOOP 1 and LOOP2.
- Alarm acknowledge;
- Outputs block.



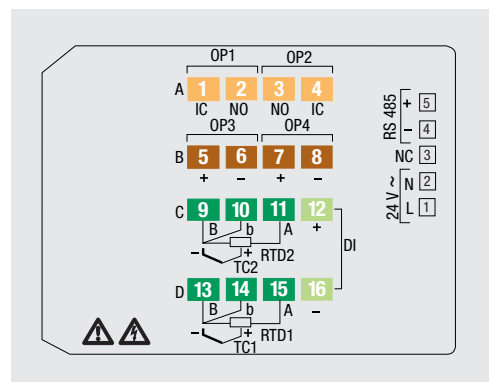

Electrical connections

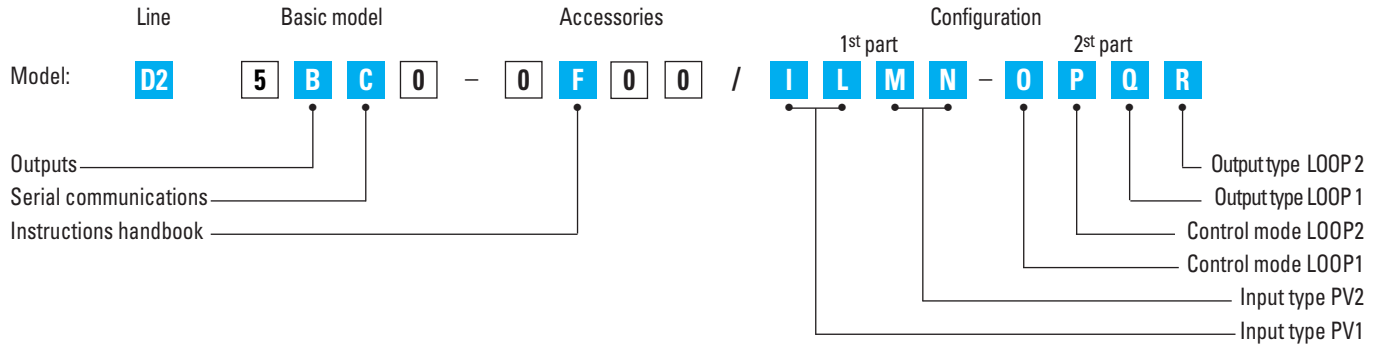

Ordering codes



OP1 and OP2 Outputs	B
Relay/Relay	1
Relay/SSR drive	2
SSR drive/SSR drive	3
SSR/SSR	4
SSR/SSR drive	5
Serial communications	
CanBus	3
RS 485 Modbus/Jbus SLAVE	5
Instructions handbook	
Italian-English (standard)	0
French-English	1
German-English	2
Spanish-English	3

Installation kit	
Each set of interconnected controllers requires one model AD3-KIT/BA.RT.PC.CD kit:	
Power supply and serial communications connector code AD3/BA	
Connector with termination resistor for serial communications code AD3/RT	
Couple of connector protections code AD3/PC	
CD Rom with configuration software tool code AD3/CD	

Input type	Range scale	PV1	I	L
Input type	Range scale	PV2	M	N
TR Pt100 IEC751	-99.9...300.0 °C	-99.9...572.0 °F	0	0
TR Pt100 IEC751	-200...600 °C	-328...1112 °F	0	1
TC L Fe-Const. DIN43710	0...600 °C	32...1112 °F	0	2
TC J Fe-Cu45% Ni IEC584	0...600 °C	32...1112 °F	0	3
TC T Cu-CuNi	-200...400 °C	-328...752 °F	0	4
TC K Chromel -Alumel IEC584	0...1200 °C	32...2192 °F	0	5
TC S Pt10%Rh-Pt IEC584	0...1600 °C	32...2912 °F	0	6
TC R Pt13%Rh-Pt IEC584	0...1600 °C	32...2912 °F	0	7
TC B Pt30%Rh-Pt Pt6%Rh IEC584	0...1800 °C	32...3272 °F	0	8
TC N Nichrosil-Nisil IEC584	0...1200 °C	32...2192 °F	0	9
TC E Ni10%Cr-CuNi IEC584	0...600 °C	32...1112 °F	1	0
TC Ni-NiMo 18%	0...1100 °C	32...2012 °F	1	1
TC W3%Re-W25%Re	0...2000 °C	32...3632 °F	1	2
TC W5%Re-W26%Re	0...2000 °C	32...3632 °F	1	3
0...50mV linear	Engineering units		1	4
10...50mV linear	Engineering units		1	5
mV "Custom" scale	On request		1	6
Action type	LOOP 1		O	
Action type	LOOP 2		P	
ON/OFF reverse action			0	
ON/OFF direct action			1	
PID reverse single action			2	
PID direct single action			3	
Control output type	LOOP1		Q	
Control output type	LOOP 2		R	
None			0	
OP1			1	
OP2			2	

**If not differently specified the controller will be supplied with standard version
Model: D2 5350-0000**

DX line - Manager Gateway

ASCON spa
20021 Bollate
(Milan) Italy
Via Falzarego, 9/11
Tel. +39 02 333 371
Fax +39 02 350 4243
<http://www.ascon.it>
e-mail sales@ascon.it

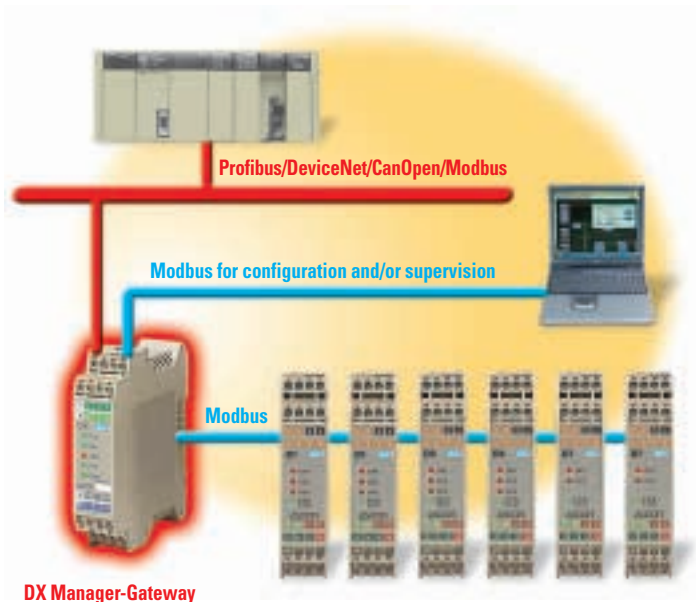

Electrical connections

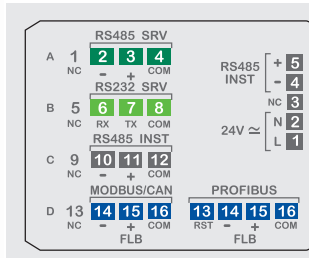

Ordering codes

Line Basic model Accessories Configuration

Model: **DX** **5** **B** **C** **0** - **0** **F** **0** **0** / **0** **0** **0** **0**

N° of instruments backed up ————

Fieldbus communications ————

Instructions handbook

Number of instruments to be backed up	B
4	1
8	2
16	3
32	4

Fieldbus communications	C
None	0
CANopen	3
RS 485 Modbus/Jbus	5
Profibus DP slave	7

Instructions handbook	F
Italian-English (standard)	0
French-English	1
German-English	2
Spanish-English	3

If not differently specified the controller will be supplied with standard version Model: DX 5100-0000

Technical data

Features at env. 25°C	Description	
Functions	Manager OFF line configuration and parameterization. Backup of the configuration and parameter data of the connected modules. Hot swapping, automatic configuration and parameterization of the replaced modules	
	Gateway Network adapter for Profibus DP, DeviceNet, CANopen and RS485/RS232 converter	
Communications ports	Instruments Bus RS485 Modbus protocol master replicated on the terminal connectors (max. 19200 baud)	
	Support RS485, RS232 Modbus protocol slave, isolated (max. 38400 baud)	RS485 Modbus protocol slave, isolated (max. 57600 baud)
		Fieldbus Profibus DP slave DP control: SPC3 DP interface: RS485 isolated, max. 12 Mb/s
	General characteristics	