

Push Button Pt100 & Thermocouple
ZTT11 In Head Temperature Transmitter

INDEX

SECTION	CONTENTS	PAGE NO.
1.0	DESCRIPTION	1
2.0	SPECIFICATION	2
3.0	INSTALLATION	3
4.0	RANGES	6
5.0	METHODS	7

1.0 DESCRIPTION

The ZTT11 C transmitter is an in head (4 to 20) mA transmitter that connects to a standard thermocouple sensor and converts the sensor temperature to a (4 to 20) mA signal. It is available in a choice of four versions to accommodate 9 thermocouple types.

The ZTT11 R transmitter is an in head (4 to 20) mA transmitter that connects to any standard Platinum resistance sensor and converts the linearised temperature to a (4 to 20) mA signal.

An LED provides a visual indication of sensor fault and programming mode. Both transmitters are simply ranged and calibrated on the bench by using a single on-board push button switch, without the need for soldering links. Digital technology ensures accurate and drift free linearisation to common curves, providing a level of performance not possible with earlier analogue types.

2.0 SPECIFICATION @ 20 °C

2.1 INPUT RANGES*

ZTT11 C	K (-200 to 1370) °C	J (-200 to 1000) °C	T (-200 to 400) °C
ZTT11 C	R (0 to 1760) °C	S (0 to 1760) °C	B (0 to 1820) °C
ZTT11 C	J (-200 to 1200) °C	L (-200 to 1200) °C	E (-200 to 1000) °C
ZTT11 C	K (-200 to 1370) °C	N (0 to 1300) °C	R (0 to 1760) °C

*Other combinations available to special order.

2.2 INPUT

Accuracy	± 0.04 % FS ± 0.04 % RDG or 0.5 °C (whichever is greater)
Linearisation	BS 4937/ IEC 584, EN60584
Cold Junction Tracking	0.02 °C/°C
Cold Junction Range	(-20 to 70) °C
Min Span	10 °C
Sensor Lead Length	Maximum length 3 m to maintain CE compliance
Sample Rate	500 ms ZZ

2.3 SPECIFICATION @ 20 °C

2.4 INPUT

Input Type	3 wire Pt100, Pt500 or Pt1000 (depending upon option)
Linearisation	BS EN 60751 (IEC751) BS 1904 (DIN 43760) JISC 1604
Max Excitation Current	Pt100 1 mA Pt500 0.5 mA Pt1000 0.1 mA
Range	(-200 to 850) °C
Minimum Span	20 °C
Lead Resistance	< 10 Ω per leg (balanced)
Burnout	Upscale 22 mA (Downscale preset current to order). Red programming LED illuminates when temperature is outside (-200 to 850) °C range
Sensor Lead Length	< 3 metres to maintain CE compliance
Sample Rate	500m S per reading
Accuracy	± 0.1°C ± 0.1 % of reading range (-100 to 500) °C ± 0.2 °C ± 0.1 % of reading range (-200 to 850) °C
Thermal Drift	Zero Span ±0.01 °C/°C
Connections	0.005 %/°C Screw terminals

2.5 OUTPUT GENERAL

Output	(4 to 20) mA, 2 wire loop powered
Maximum Output Range	(3.8 to 22) mA
Ambient Temp. Range	(-20 to +70) °C
Operating Voltage	(8 to 30) VDC
Warm-up Time	120 s to full accuracy
Protection	Reverse polarity protected
Connections	Screw terminals
Dimensions	43 mm diameter 21 mm height
EMC	BS EN 61326

2.6 OUTPUT

Burnout	Upscale >21 mA (Downscale to order). Red programming LED comes on when temperature is outside operating range
Input/Output Isolation	50 VDC (Tested to 200 V)
Ambient Humidity	(0 to 95) % (Non condensing)
Ambient Storage	(-40 to 90) °C
Calibration Period	12 months to maintain published specification. 5 years to twice specification
Weight	30 g

2.7 OUTPUT

Accuracy	± 5 μ A
Thermal Drift	± 1 μ A/°C
Response Time	500 ms to reach 70% of final value
Loop Resistance	800 Ω @ 24 VDC
Loop Sensitivity	0.4 μ A/volt
Loop Noise	± 0.001 μ A
Input/Output Isolation	Not isolated
Ambient Storage	(-40 to 80) °C
Ambient Humidity	(0 to 95) % (Non condensing)
Weight	26 g
Default Range	(0 to 100) °C. Please contact sales office for factory configuration to any other range.

3.0 INSTALLATION

3.1 MECHANICAL

Both transmitters has been specifically designed to be mounted inside a DIN Standard probe head enclosure, which must provide adequate protection from moisture, corrosive atmosphere etc. All cable entries should be sealed using the correct size cable gland. Care must be taken when locating the transmitter to ensure the ambient temperature will remain inside the specified range of (-20 to 70) °C. The following diagrams show the mechanical layout and a typical application of the transmitter mounted inside a probe head enclosure, with sensor wires entering through the centre hole.

FIGURE 1

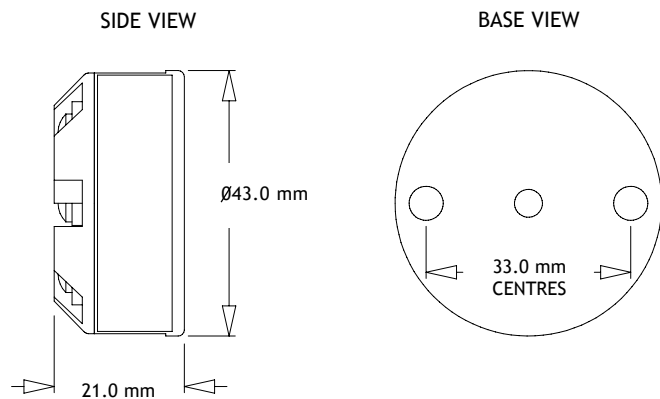

Mounting holes: 2 holes 5.5 mm diameter, 33 mm centres
Centre hole sensor wire entry: 4.0 mm diameter

FIGURE 2

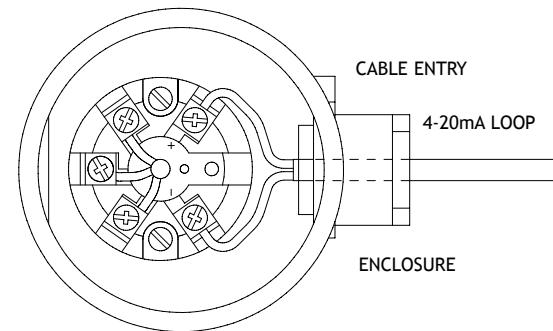

3.2 ELECTRICAL

Connections to the transmitter are made to the screw terminals provided on the top face. To maintain CE compliance, input wires must be less than 3 m in length and output wiring must be screened cable with the screen earthed at one end only. ZTT11 R all three input wires must have the same core diameter to maintain equal lead resistance in each wire. A hole is provided through the centre of the transmitter to allow sensor wires, (entering direct from the probe assembly via a base entry) to be threaded through the transmitter body, direct to the input screw terminals. The screw terminals have been designed to allow all connection wires to enter from either an inner or outer direction.

The transmitter is protected against reverse connection, therefore incorrect connection of the output wires will result in near zero current flow in the loop. ZTT11 R incorrect connection of the sensor wires will result in the transmitter output going to burnout condition. For the ZTT11 C on power-up the LED also indicates the thermocouple type by flashing once, twice or three times, the number of flashes representing the index of the thermocouple type shown on the transmitter label.

Figure 3 overleaf shows the method of connection for ZTT11 C to provide a (4 to 20) mA current loop output. The TC sensor shown would normally take the form of a probe assembly. The output loop shows a power supply, used to provide loop excitation, the transmitter, and a load, all connected in series.

Figure 4 shows the method of connection for the ZTT11 R to provide a (4 to 20) mA current loop output. The Platinum resistance sensor shown would normally take the form of a probe assembly with a three wire output. The output loop shows a 24 VDC power supply, used to provide loop excitation, the transmitter, and a load, all connected in series.

The load symbol on both represents other equipment in the loop e.g. indicators, controllers, loggers etc.

FIGURE 3

CONNECTION DIAGRAM

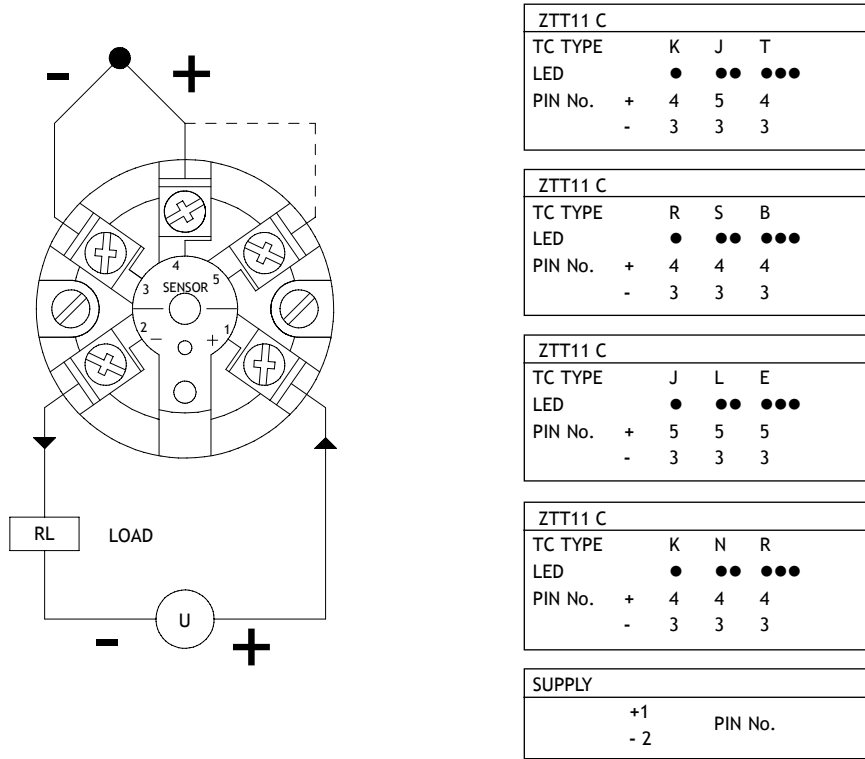
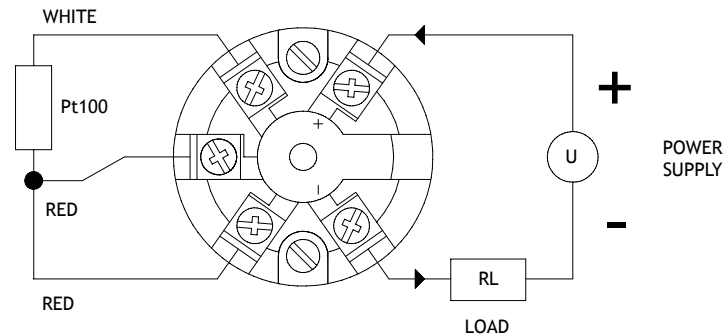

FIGURE 4

CONNECTION DIAGRAM



BURNOUT

Due to the sensing method, certain combinations of open circuit sensor wires may result in the output current dropping for approximately 500mS, before rising to upscale output.

Care must be taken when designing the (4 to 20) mA circuit to ensure that the total load of the loop, that is the total voltage requirements of all the equipment in the loop added together, does not exceed the power supply voltage. If a number of devices are connected in the loop, ensure that only one instrument is connected to ground. Grounding the loop at two points will result in shorting out part of the loop and therefore any transmitters in that part of the loop will not operate.

Maximum load resistor, R_L , is calculated as follows:

$$R_L = (V-8)/20 \times 1000$$

For 24 V supply:

$$R_L = (24-8)/20 \times 1000 = 800 \Omega$$

3.3 EMC

This transmitter conforms with EC directives BS EN 61326 when correctly installed in a termination head providing at least IP20 protection and fitted with a sensor with less than 3 m of cable.

4.0 RANGES

The ZTT11 R transmitter is normally supplied ranged (0 to 100) °C, unless a special range has been requested at the time of order.

With the aid of suitable equipment, both transmitters can be programmed to a different range by following the simple procedure listed overleaf.

4.1 EQUIPMENT

The following apparatus will be required in order to re-range the transmitters:-

ZTT11 C

- Power supply voltage 24 VDC, 30 mA min current
- TC calibrator
- Connecting cables, including TC compensating cables
- 3 mm diameter screw driver or similar device.
- Current meter (0 to 20) mA to monitor loop current (Optional).

ZTT11 R

- Power supply voltage between (10 to 30) VDC, 30 mA min current
- RTD Calibrator or Precision resistance box (0 to 390) Ω
- Connecting cables
- 3 mm Diameter screw driver or similar device.
- Current meter (0 to 20) mA to monitor loop current (Optional).

5.0 METHOD

Refer to Figure 2 and 5 for correct connection and type setting details, this information is duplicated on the transmitter side label.

5.1 SETTING THE THERMOCOUPLE TYPE

Each transmitter accepts three different thermocouple types as shown on the side label. At switch on the indicator flashes the appropriate number of times to indicate the thermocouple type selected.

The thermocouple type may be changed by performing the following procedure:

1. Power on the transmitter with the programming switch depressed. (Press the programming switch by inserting a 3 mm diameter screwdriver blade through the programming hole, located in the top face of the transmitter housing).
2. Release the programming switch and press the switch down 1, 2 or 3 times depending upon the TC type required.
3. After approximately 5 s time-out the instrument will restart and confirm the TC type by flashing the LED the number of times programmed.

5.2 SETTING THE RANGE

1. Connect circuit as shown in Figure 3 and set the TC calibrator for temperature required at 4 mA, switch on and allow 120 s warm up time (for best accuracy).
2. Press and hold the programming switch by inserting a 3 mm diameter screwdriver blade through the programming hole, located in the top face of the transmitter housing. Hold the switch for approximately 5 s, until the RED programming LED flashes. Release the switch.
3. Set the calibrator for the required temperature at 20 mA. Allow 10 s settling time, then press and release the programming switch. The programming LED will flash quickly for a few moments, then go out. The transmitter is now ranged.
4. Check the transmitter output range is correct by setting the calibrator to the 4 mA and then 20 mA settings, checking the output current reading on the meter.

FIGURE 5 CALIBRATION CIRCUIT ZTT11 C

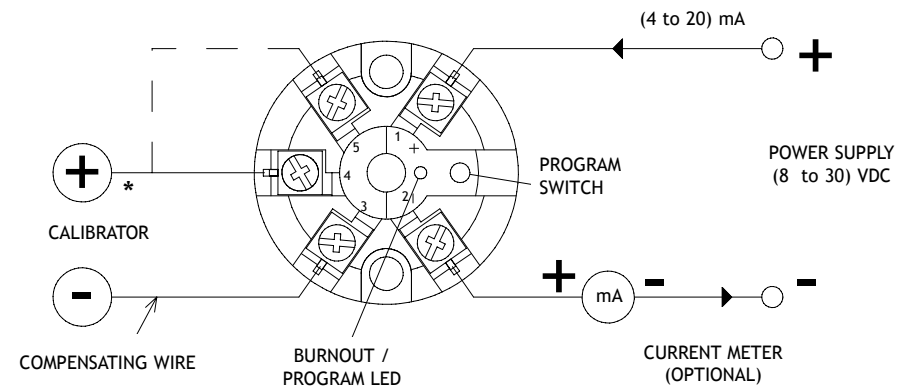

* Connect as Figure 3 table.

5.3 METHOD

1. Connect circuit as shown in the figure below and set the RTD calibrator for temperature required at 4 mA.
2. Press and hold the programming switch by inserting a 3 mm diameter screw driver blade through the programming hole, located in the top face of the transmitter housing. Hold the switch for approximately 5 s, until the RED programming LED flashes. Release the switch.
3. Set the RTD calibrator for the required temperature at 20 mA. Allow 10 s settling time, then press and release the programming switch. The programming LED will flash quickly for a few moments, then go out. The transmitter is now ranged.
4. Check the transmitter output range is correct by setting the RTD calibrator to the 4 mA and then 20 mA settings, checking the output current reading on the meter.

FIGURE 6 CALIBRATION CIRCUIT

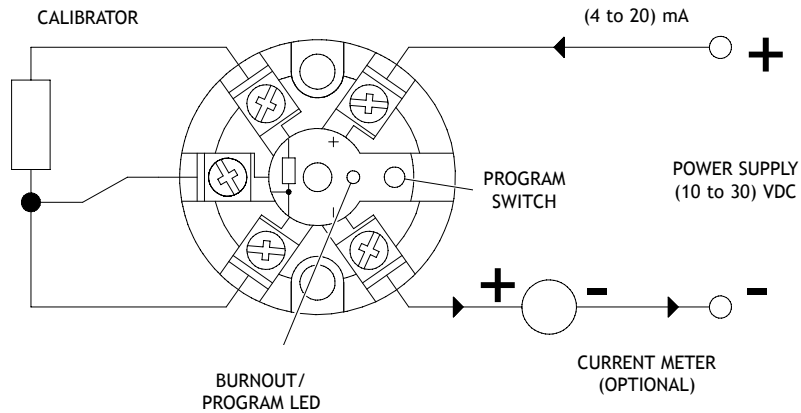

ALSO AVAILABLE:

- Smart In Head Temperature Transmitters
- Din Rail Mounted Temperature Transmitters
- Panel & Field Temperature Indicators
- Temperature Probes
- Signal Conditioners
- And many other products

For further information on all products: