

# Configurable Multi-input, Multi-output or Multi-set point Controller **XS** Series



## INSTRUCTION MANUAL

MIU.XS-6/96.10/E

COD J30-154-1AXS ING



**ASCON spa**

## GENERAL INDEX

- 1 IDENTIFICATION OF MODEL ..... page 1
- 2 FUNCTION OF KEYS AND DISPLAYS..... page 3
- 3 DIMENSIONS, INSTALLATION ..... page 6
- 4 ELECTRICAL WIRING..... page 7
- 5 Y2 - Y3 AUXILIARY OUTPUTS ..... page 13
- 6 PASSWORDS ..... page 15
- 7 PROGRAMMING PROCEDURE (see enclosed leaflet)  
CONFIGURATION  
PARAMETERS
- 8 OPERATING DIRECTIONS (see enclosed leaflet)  
SET POINT  
AUTO/MAN  
LOC/REM  
AUTO-TUNE
- 9 MODIFYING THE OPERATING STATE ..... page 16
- 12 TECHNICAL DATA ..... page 17

SERIAL COMMUNICATION  
(see DIRECTIONS FOR USE “serial communication  
supplement” MIU.XS-CS/E supplied separately)

# 1 • IDENTIFICATION OF MODEL

Thank you for choosing an ASCON controller

The instruments of the XS series belong to the last generation of microprocessor based controller, are universal, very powerful but simple to use.

They are fitted with AUTO-TUNE and EXPERT-TUNE, an auxiliary for system start-up, and serial communication for introduction into a distributed control network.

They are complete because all possible variables are always present. Configuration of the instrument permits determination of the operating mode according to the application required.

## 1.1 Identification of model

**Model code**

**XS - ABCD /**

Configuration code

Beginning and end of scale

<b>OPTIONS</b>	<b>Power supply</b>	<b>A</b>
	100 ...240 V 50/60 Hz	<b>3</b>
	16 ...28 V 50/60 Hz and 20...30 Vdc	<b>5</b>
	<b>Serial communications</b>	<b>B</b>
	None	<b>0</b>
	20mA C.L. Std Ascon protocol	<b>1</b>
	20mA C.L. Modbus/Jbus protocol	<b>2</b>
	<b>Retransmission output Y4</b>	<b>C</b>
	None	<b>0</b>
	Fitted (4...20 mA or 0...10 Vdc)	<b>1</b>
	<b>Set point</b>	<b>D</b>
	Standard (up to 4 mem. or Loc./Rem.)	<b>0</b>
	Time-programmable (11 segments)	<b>1</b>

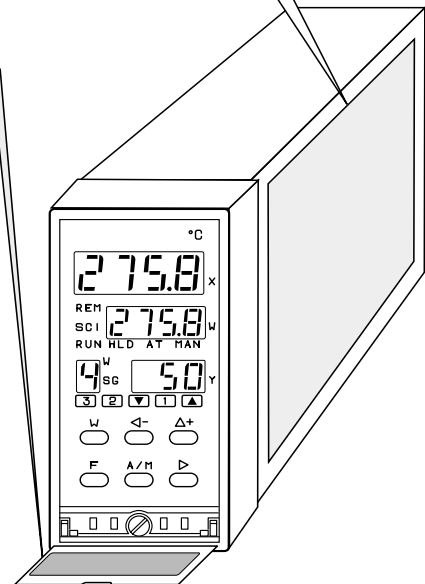

# 1 • IDENTIFICATION OF MODEL

## 1.2 Configuration code

**Configuration code**  
**EFGH - ILMN /** Beginning and end of scale **O . . . . P**

Model code

1st part	Input X	E
	Main output Y1	F
2nd part	Auxiliary output Y2	G
	Auxiliary output Y3	H
	Retransmission output Y4	I
	Set point W	L
<b>Beginning and end of scale</b> (for configurable scales only)		M
		N
		O
		P

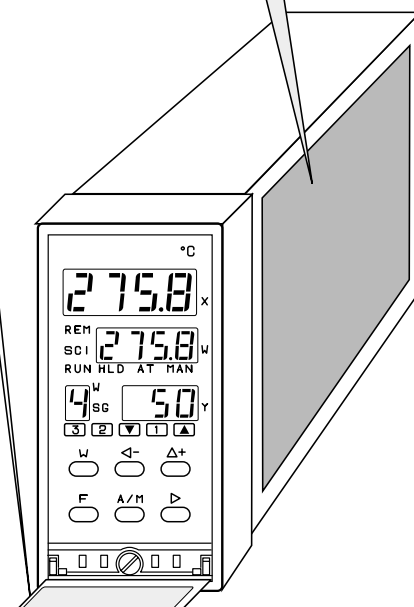

The controller is normally configured in the factory.



If this appears on starting

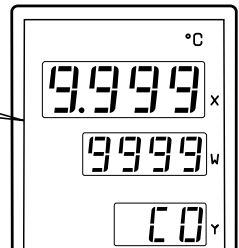



the controller **IS NOT CONFIGURED**

**In order to configure the controller, follow the configuration procedure reported in the enclosed leaflet**

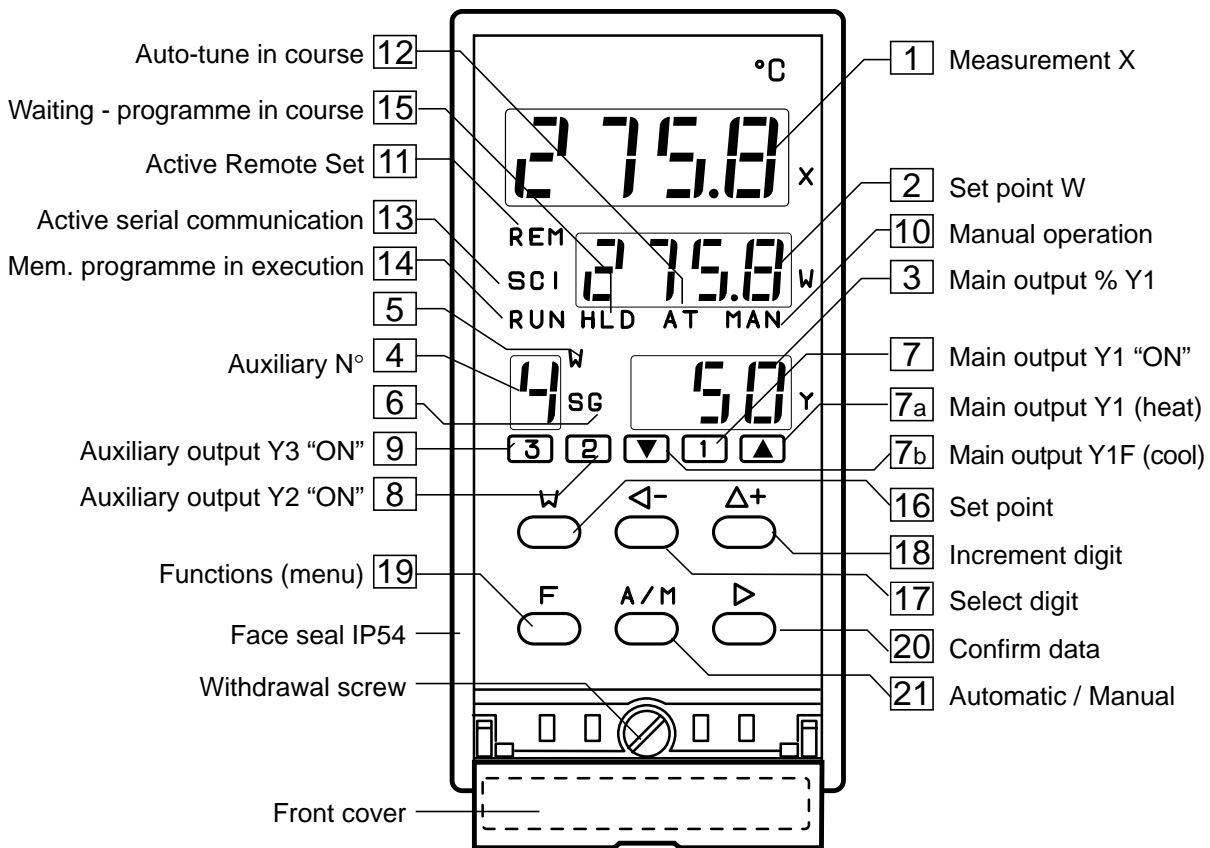
## 2 • FUNCTION OF KEYS AND DISPLAYS

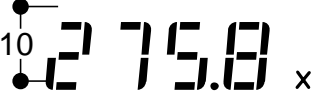
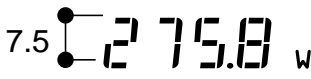
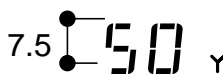
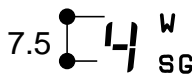
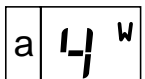
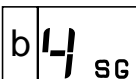

### NUMERIC INDICATORS X, W, Y, N°

<p>1- Measure X (green)</p>	<p>The value of measure X is expressed in engineering units.</p> <p>If above end of scale </p> <p>If below beginning of scale </p> <ul style="list-style-type: none"> <li>- In programming: displays parameter values</li> <li>- In configuration: displays the values of the 1<sup>st</sup> part of the configuration code (see enclosed leaflet)</li> </ul>
<p>10 </p>	
<p>2- Set point W (green)</p>	<p>Displays the operating Set point value (Local or Remote)</p> <ul style="list-style-type: none"> <li>- In programming: displays the parameter codes</li> <li>- In configuration: displays the index values of the 2<sup>nd</sup> part of the configuration code (see enclosed leaflet)</li> </ul>
<p>7.5 </p>	
<p>3- Output Y1(green)</p>	<p>Displays the value of main output Y1 from 0...100% (from - 100 to 100% for Y1 with dual action)</p> <ul style="list-style-type: none"> <li>- In configuration: Displays the mnemonic code [ ]</li> </ul>
<p>7.5 </p>	
<p>4- Auxiliary N° (green)</p> <p>7.5 </p> <p>a  b </p>	<p>Normally off, lights up to display</p> <p>a - the selected N° of 1 of the 4 stored Set points , in which case led 5 "W" lights up too</p> <p>b - the N° of the segment in execution (option with programmable set, see chapter 11) in this case, led 6 "SG" lights up too</p>

## 2 • FUNCTION OF KEYS AND DISPLAYS





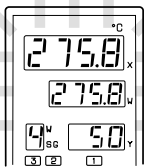

### LEDS FOR OUTPUT STATE

7 - Output Y1 (red)	Lit with output Y1 "ON" De-activated with continuous or dual action discontinuous output	<b>Only for HEAT/COOL dual action discontinuous control</b>
1		
7a - Output Y1 (heat)	Lit with output Y1 (heat) "ON"	
▲		
7b - Output Y1F (cool)	Lit with output Y1F (cool) "ON"	
▼		
8 - Output Y2 (red)	Lit with output Y2 "ON"	
2		
9 - Output Y3 (red)	Lit with output Y3 "ON"	
3		

### LEDS FOR OPERATING STATE

10 - Manual (green)	Lit in Manual operation	
MAN		
11 - Remote (green)	Lit when the Remote Set point is operating (if off, the operating Set point is the Local one)	
REM		
12 - Auto-Tune (green)	Lit when Auto-Tune or Expert-Tune is AT in course	
AT		
13 - Serial comm. (green)	Permanently lit when the serial communication is enabled to write. Flashes with signal in transit	
SCI		
14 - In execution (green)	When lit indicates that the stored programme is in course	<b>Only for Set programmable option</b>
RUN		
15 - Waiting (green)	When lit indicates the temporary suspension of the programme in course	
HLD		
Loop - Break - Alarm		With output Y3 active and configured as Loop Break Alarm, the front displays X and W are flashing (see p. 14)

## 2 • FUNCTION OF KEYS AND DISPLAYS

KEYS			
<b>16</b> - Set Point		<p>Standard configuration: (1 Local + 4 storable used for:</p> <ul style="list-style-type: none"> <li>• modifying the Set point</li> <li>• recalling the 4 memorized Set points (see enclosed leaflet)</li> </ul> <p>Remote Set configuration: (1 Local + 1 Remote) used for:</p> <ul style="list-style-type: none"> <li>• passing from Local to Remote Set point and viceversa (see enclosed leaflet)</li> </ul> <p>Programmed Set configuration: (see chapter 11)</p> <ul style="list-style-type: none"> <li>• to recall the Local operating Set point</li> <li>• to start, stop, start again the execution of the memorized programme</li> </ul>	
<b>17</b> - Digit selection		<p>Selects the digit to be modified (see enclosed leaflet) In Manual operation, decrements the value of main output Y1</p>	<p><b>Keys for modifying numeric values of any data</b></p>
<b>18</b> - Increment digit		<p>Increments the value of the flashing digit, from 0.9 In manual operation increments the value of main output Y1</p>	
<b>19</b> - Functions		<p>Permits access to menu of functions to be programmed</p>	<p><b>Keys for data programming and processing</b></p>
<b>20</b> - Enter		<p>Enter or Scroll of values and modes of operation</p>	
<b>21</b> - Auto/Man		<p>Passage from Automatic to Manual operation and viceversa</p>	

# 3 • DIMENSIONS - INSTALLATION

## 3.1 - Overall dimensions (in compliance with DIN 43700)

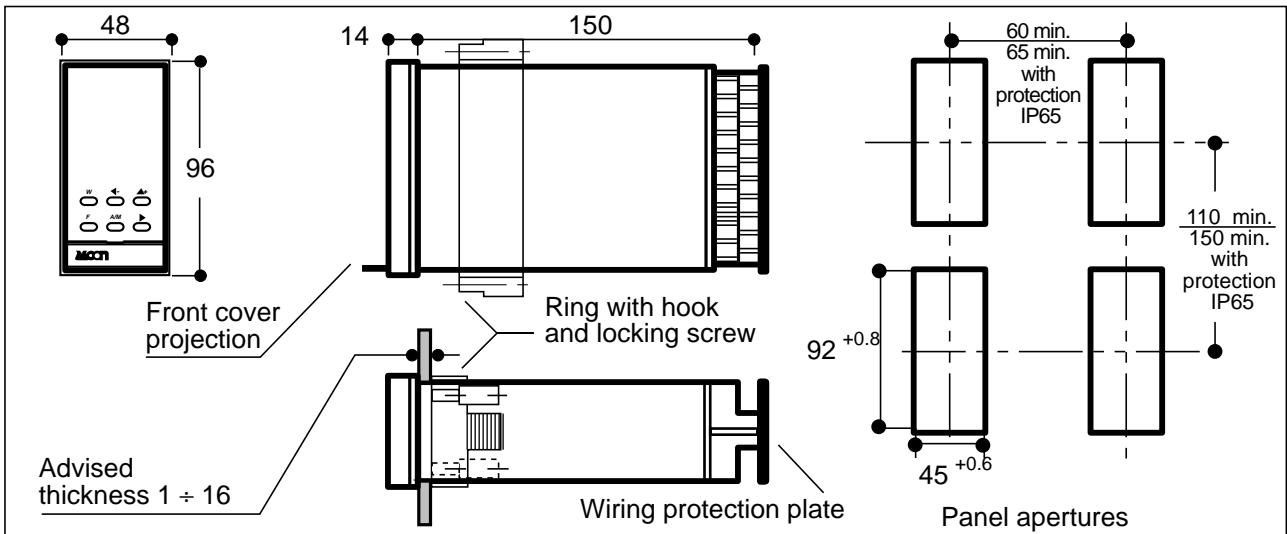

## 3.2 - Panel installation

### A • Panel fitting

- Install away from:
- heat sources
  - corrosive gases
  - dusty environments

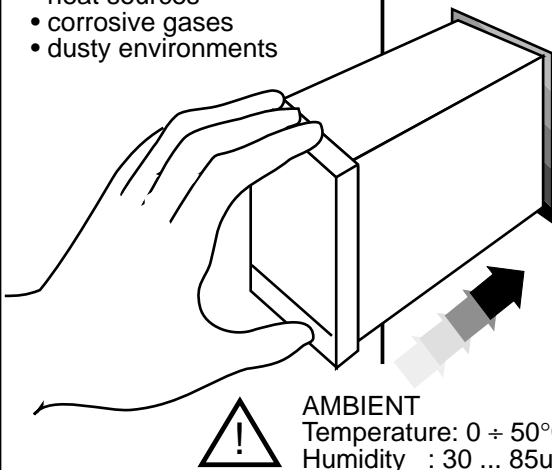

### B • Fixing with ring

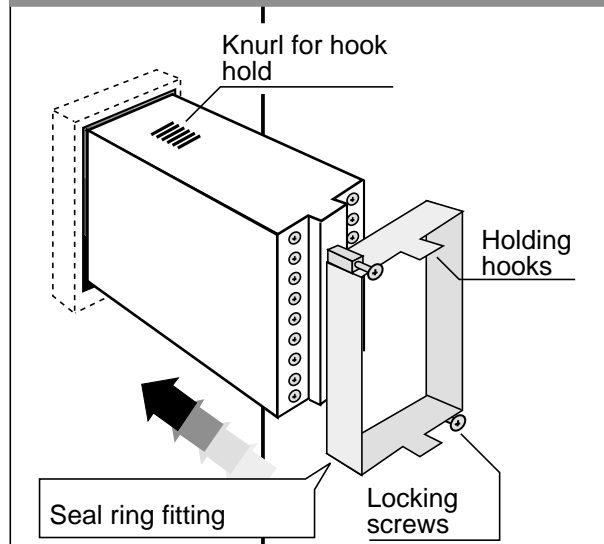

### C • Screw locking

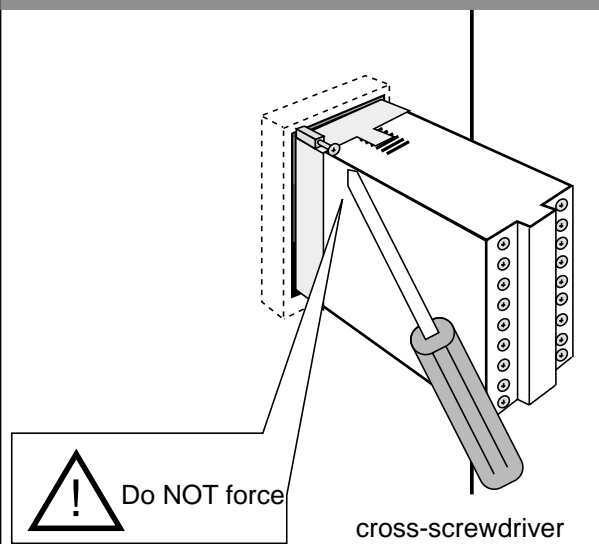

### D • Plate for engineering units

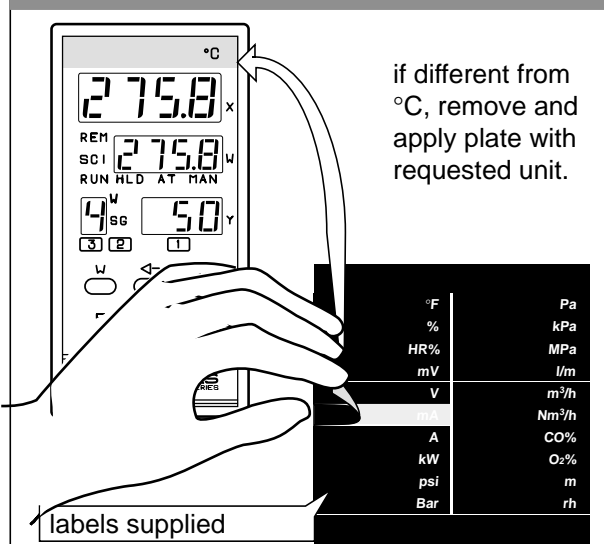

# 4 • ELECTRICAL WIRING

## A • Terminal board

28 screw terminals M3.5

Plate pin

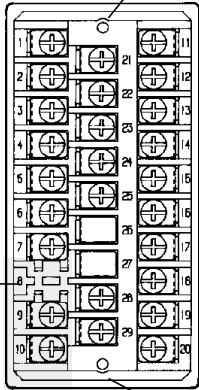

Wiring protection plate

Plate screw

Cold joint compensation thermometer

3 gilded terminals for input signals

## B • Freeing the terminals

1 Lift the plate to free the pin

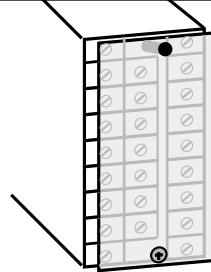

2 Rotate downwards

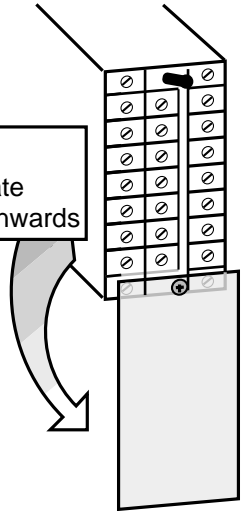

## C • Effecting the connections

With eyelet terminals

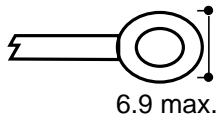

Cable section

wires N°

2

With fork terminals

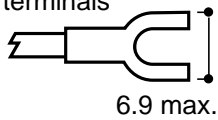

0.25 ÷ 2.5 AWG  
22 ÷ 14

1

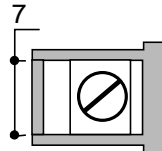

With tinned wire

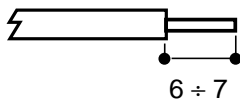

2

Preferential

## D • Protecting the terminal board

1 Rotate upwards

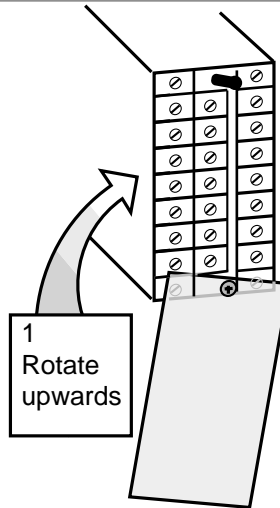

2 Depress the plate to engage the pin

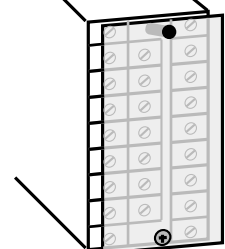

# 4 • ELECTRICAL WIRING

Although this controller is designed to resist the heaviest disturbances present in industrial environments (level IV of standard (IEC 801-4), it is advised to keep to the following precautions:

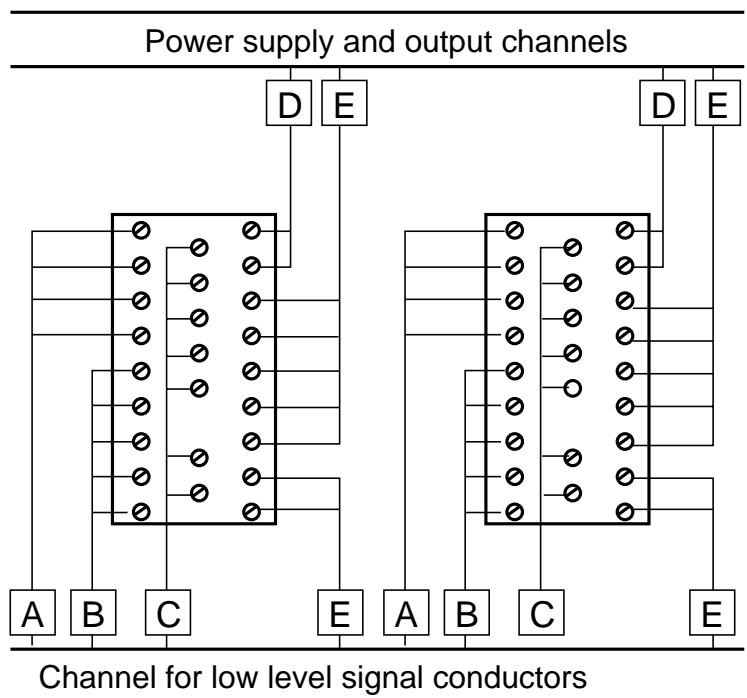
Precautions	Advised conductor course
 Single out supply line from power line  Keep away from teleruptors, electromagnetic contactors and powerful motors  Keep away from power groups, in particular if with phase control	
Serial communication <span style="border: 1px solid black; padding: 2px;">A</span>  Analogic inputs <span style="border: 1px solid black; padding: 2px;">B</span>  Logic inputs and analogic signals <span style="border: 1px solid black; padding: 2px;">C</span>  Input <span style="border: 1px solid black; padding: 2px;">D</span>  Outputs <span style="border: 1px solid black; padding: 2px;">E</span>	

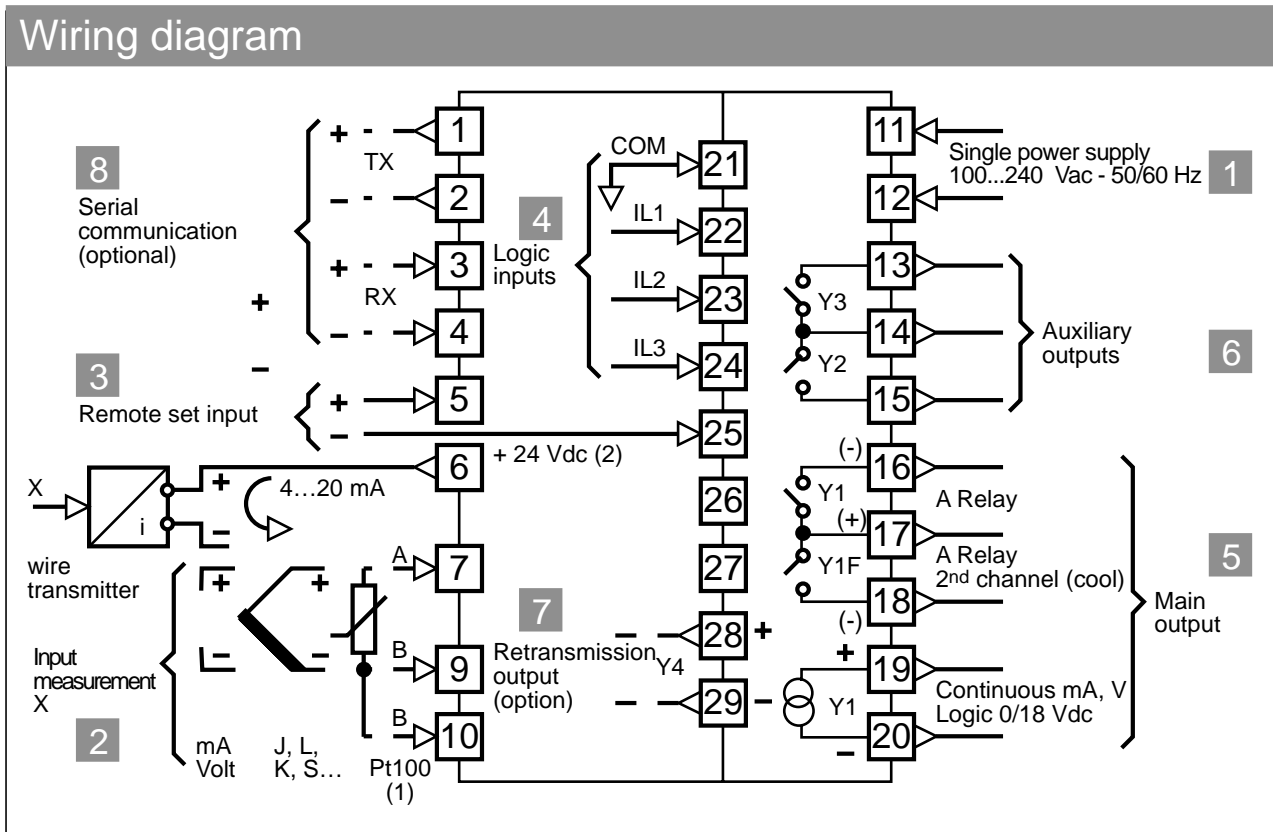

# 4 • ELECTRICAL WIRING

## 1 • Single power supply

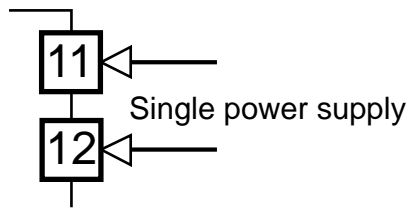

"Switching" type

- Standard: 100 to 240 Vac - 15% + 10%
- for low tension: 24 Vac -15% + 10%

24 Vdc  $\pm$ 15%

Absorbed power 4VA

## 2 • "X" measurement input

### A - For thermocouples J-L-K-S-R

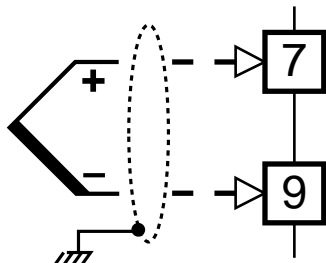

Line: max. 150  $\Omega$

- Respect polarities
- For eventual extensions, use a compensated cable suitable for the type of thermocouple used
- The eventual screen is well earthed at only one end

### B - For RTD Pt100

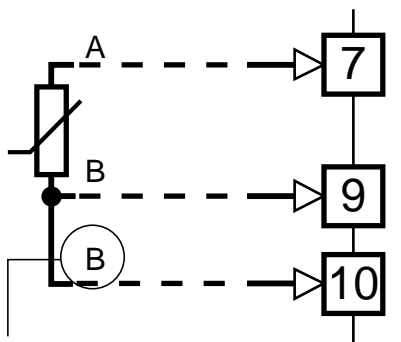

for 3-wire connection only  
Line: max. 20  $\Omega$  per wire

- For 3-wire connection, use cables of same section (min. 1 sq.mm)
- For 2-wire connection, use cables of adequate section (min. 1.5 sq.mm.)

Note:  
with a 15 m. probe-controller distance and a 1.5 sq.mm. section cable, the error is about 1°C.

### C • Continuous, mA, Volt

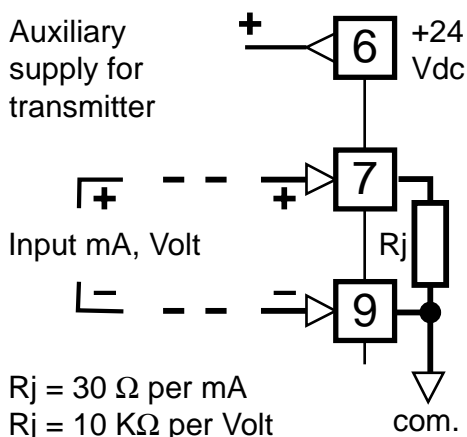

#### For 2-wire transmitter

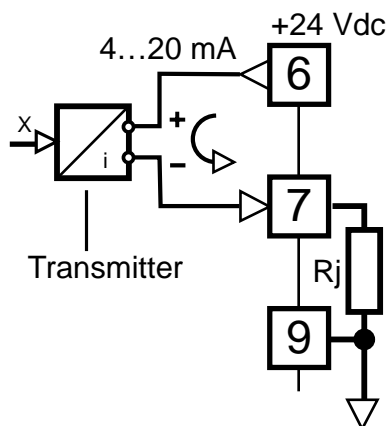

#### For 3 or 4-wire transmitter

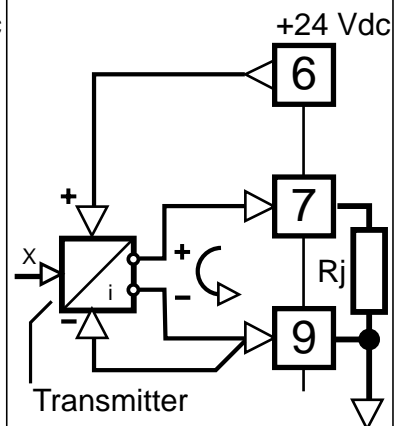

## 4 • ELECTRICAL WIRING

### 3 • Remote Set point input

$R_j = 30 \Omega$  per mA  
 $R_i = 330 K\Omega$  per V

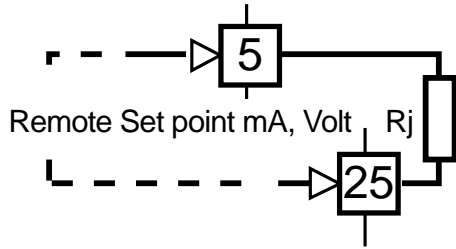

In current 4..20 mA  
 In voltage 0..10 Vdc

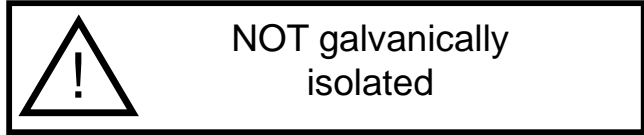

### 4 • Logic inputs

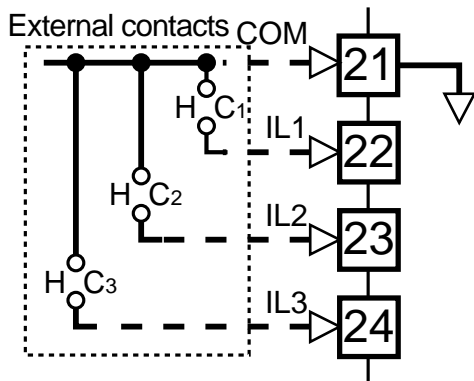

An impulsive (2 sec. at least) closing of contacts C1, C2, C3, permits the passage from AUTO/MAN, from Local/Remote Set point, recalling the 4 memorized Set points and launching of the programmed Set point. (see p. 16)

### 5 • Main output Y1

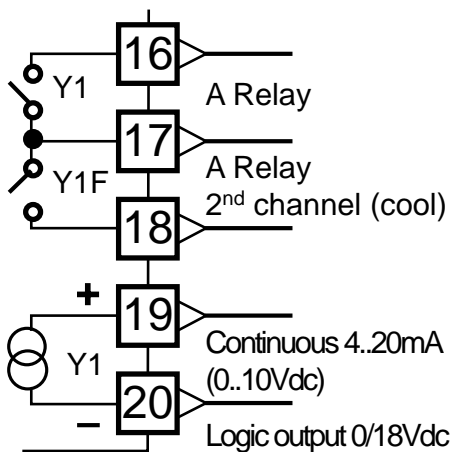

Universal and galvanically isolated. 2 relays are simultaneously present for discontinuous output with single or dual action (HEAT:COOL) and the signal for standard continuous output 4..20mA (or 0..10Vdc) which can also be Logic output 0/18Vdc).



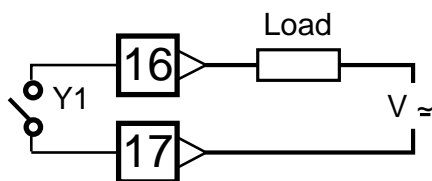

#### A • Single with Relay

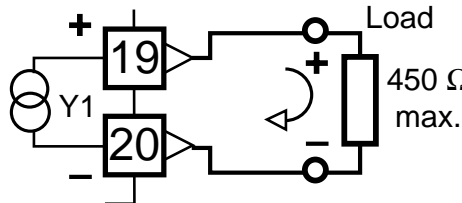
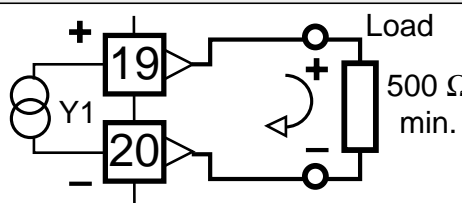

NA contact, capacity 5A/250Vac for resistive loads (transition  $2 \times 10$  (coeff.5) min. at 5A/250Vac)

# 4 • ELECTRICAL WIRING

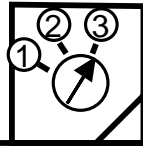
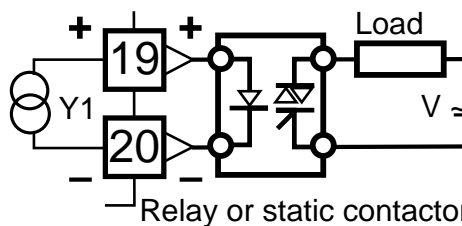
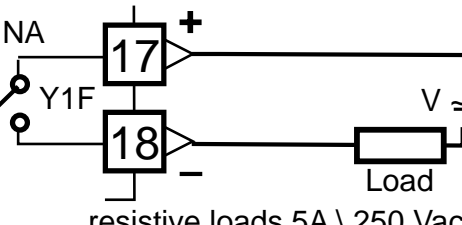
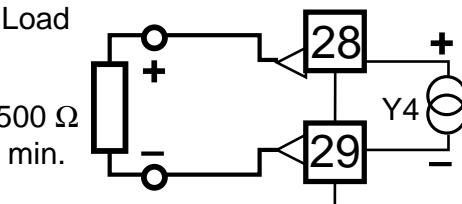
## 5 • Main output Y1 (continued)

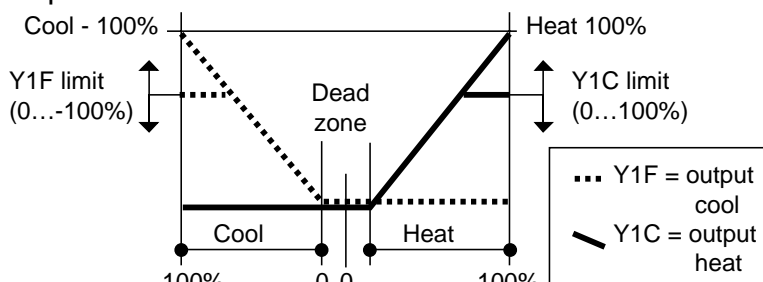
<p><b>B • single in current</b></p> 	<p>Continuous output 4..20mA galvanically isolated</p>																																					
<p><b>C • single in voltage</b></p> 	<p>Continuous output 0..10Vdc galvanically isolated</p>	<p style="text-align: center;"></p> <p>Position the switch set inside the controller too</p> 																																				
<p><b>D • single logic</b></p> 	<p>Output 0/18Vdc (20mA max.) galvanically isolated</p>	<p>① Continuous output 4...20mA Standard ② Continuous output 0...10Vdc ③ Logic output 0...18Vdc</p>																																				
<p><b>E • Dual action relay</b></p>  <p>resistive loads 5A \ 250 Vac</p>	<p>For controllers with dual action output Y1 (example: Heat-Cool), an extra output Y1F with Relay is available for the cooling action. If a continuous output is desired for cooling, use the retransmission output Y4 (option) configured for retransmission of the signal: Y1F (cool). Possible combinations for Y1 dual are:</p> <table border="1" data-bbox="662 1433 1428 1601"> <thead> <tr> <th>Terminals</th> <th colspan="2">16 - 17</th> <th colspan="2">19 - 20</th> <th colspan="2">16-17</th> <th colspan="2">19 - 20</th> </tr> </thead> <tbody> <tr> <td>Y1 ▲ (Heat)</td> <td>R</td> <td>R</td> <td>L</td> <td>L</td> <td>C</td> <td>C</td> <td>R</td> <td>C</td> </tr> <tr> <td>Y1 ▼ (Cool)</td> <td>R</td> <td>L*</td> <td>R</td> <td>L*</td> <td>L*</td> <td>R</td> <td>C</td> <td>C</td> </tr> <tr> <td>Terminals</td> <td colspan="4">17 - 18</td> <td colspan="4">28 - 29</td> </tr> </tbody> </table>		Terminals	16 - 17		19 - 20		16-17		19 - 20		Y1 ▲ (Heat)	R	R	L	L	C	C	R	C	Y1 ▼ (Cool)	R	L*	R	L*	L*	R	C	C	Terminals	17 - 18				28 - 29			
Terminals	16 - 17		19 - 20		16-17		19 - 20																															
Y1 ▲ (Heat)	R	R	L	L	C	C	R	C																														
Y1 ▼ (Cool)	R	L*	R	L*	L*	R	C	C																														
Terminals	17 - 18				28 - 29																																	
<p><b>F • Continuous dual action</b></p>  <p>Retransmission output Y1F (option) galvanically isolated 4...20mA, 10Vdc max. or 0...10Vdc, 20mA max.</p> <p style="text-align: center;"> See retransmission output Y4</p>	<p>where: R = Relay L = Logic C = continuous (mA or Volt) *version on request For Y1 cool, R is the extra relay of Y1, while C is the retransmission output Y4 configured to retransmit Y1 cool: 4...20mA or 0...10 Volt.</p> <p>Output feature of dual action controllers</p> 																																					

## 4 • ELECTRICAL WIRING

### 6 • Auxiliary outputs Y2 (see p. 13)

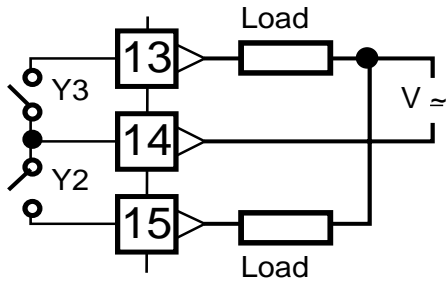

NA contacts, capacity 5A/250Vac for resistive loads (transitions 2x10 (coeff.5) min. at 5A/250Vac)

### 7 • Retransmission output Y4 (option)

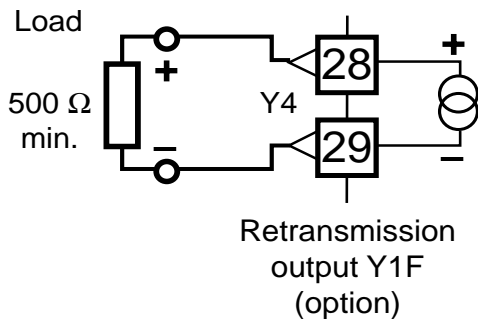

Retransmission:  
of measurement X  
of Set point W  
of output Y1F (Cool)

Galvanically isolated  
4..20mA, 10Vdc max. or  
0..10Vdc, 20mA max.

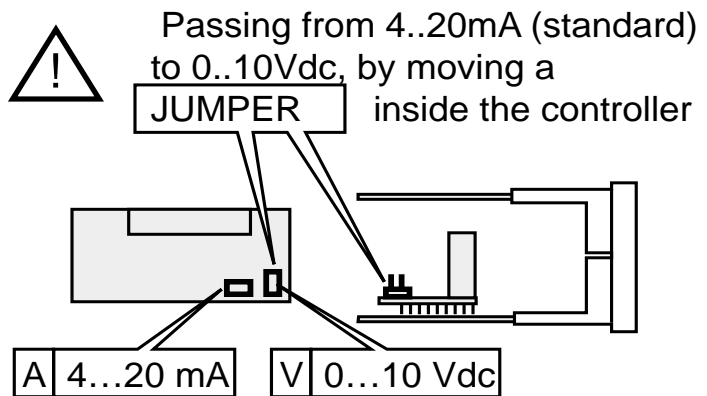

### 8 • Serial communication (option)

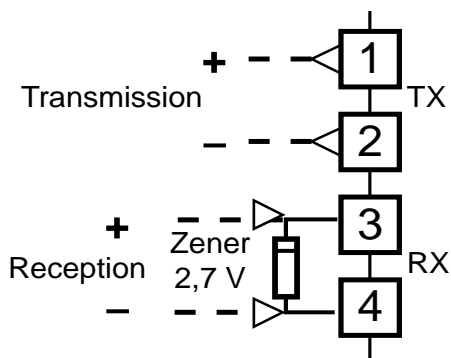

Note  
Zener 2,7 V Only for 20mA C.L.

Interface 20mA C.L. passive and galvanically isolated

**Consult Directions for use  
"SERIAL COMMUNICATION  
SUPPLEMENT" MIU-CS/E  
supplied separately.**

# 5 • Y2 - Y3 AUXILIARY OUTPUTS

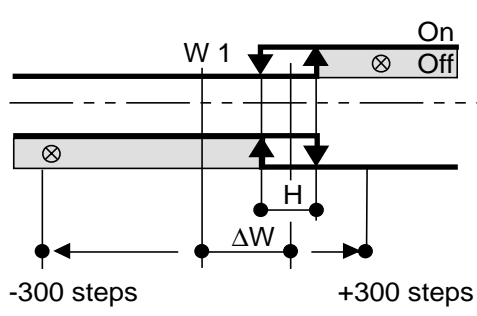
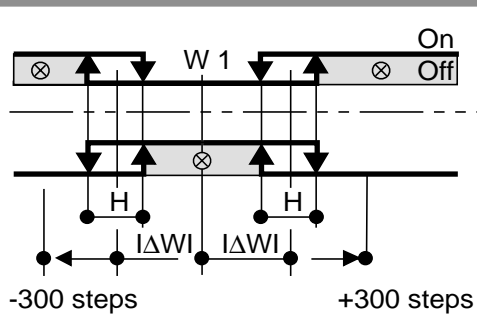
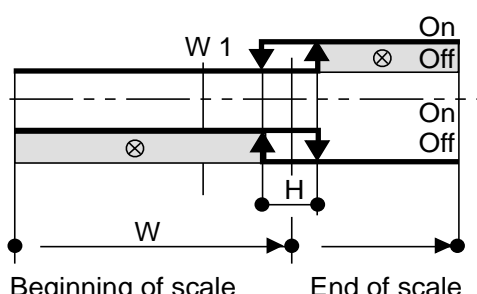
<p><b>Deviation</b></p> 	<p>Active high (above)</p> <hr/> <p>Active low (under)</p>	<p>Set point W (1) -300...+300 steps compared to W1</p>
<p><b>Band</b></p> 	<p>Active out (above)</p> <hr/> <p>Active in (under)</p>	<p>Set point I WI (1) -0...300 steps compared to W1</p>
<p><b>Independent</b></p> 	<p>Active high (above)</p> <hr/> <p>Active low (under)</p>	<p>Set point (1): from beginning to end of scale</p>

(1) - The Set point of Y2 and Y3 is not limited by the limits of the main Set point W1, but only by the scale span.

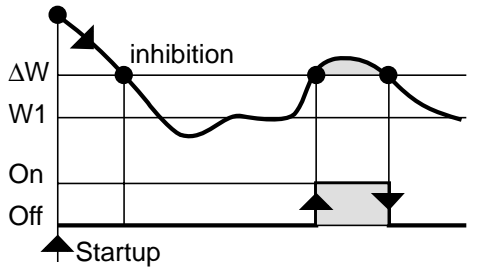
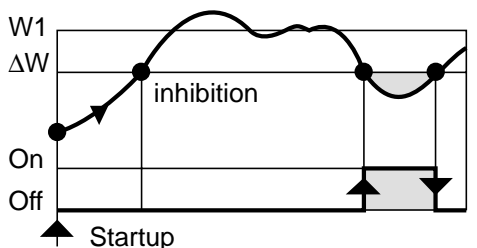
<p><b>Deviation with startup inhibition</b></p>		
	<p>Active high (above)</p>	<p>Set point W (1) -300...+300 steps compared to W1</p>
	<p>Active low (under)</p>	

## 5 • Y2 - Y3 AUXILIARY OUTPUTS

### “Loop-Break-Alarm” LBA (control loop defect/interruption)

Any interruption in the connections or any anomaly in the operation of one of the control loop components, will cause the output Y3 to be energized after a few minutes and front display X and W will be flashing.

The alarm state will stop when the anomaly causing it stops or

depressing any key for silencing it.

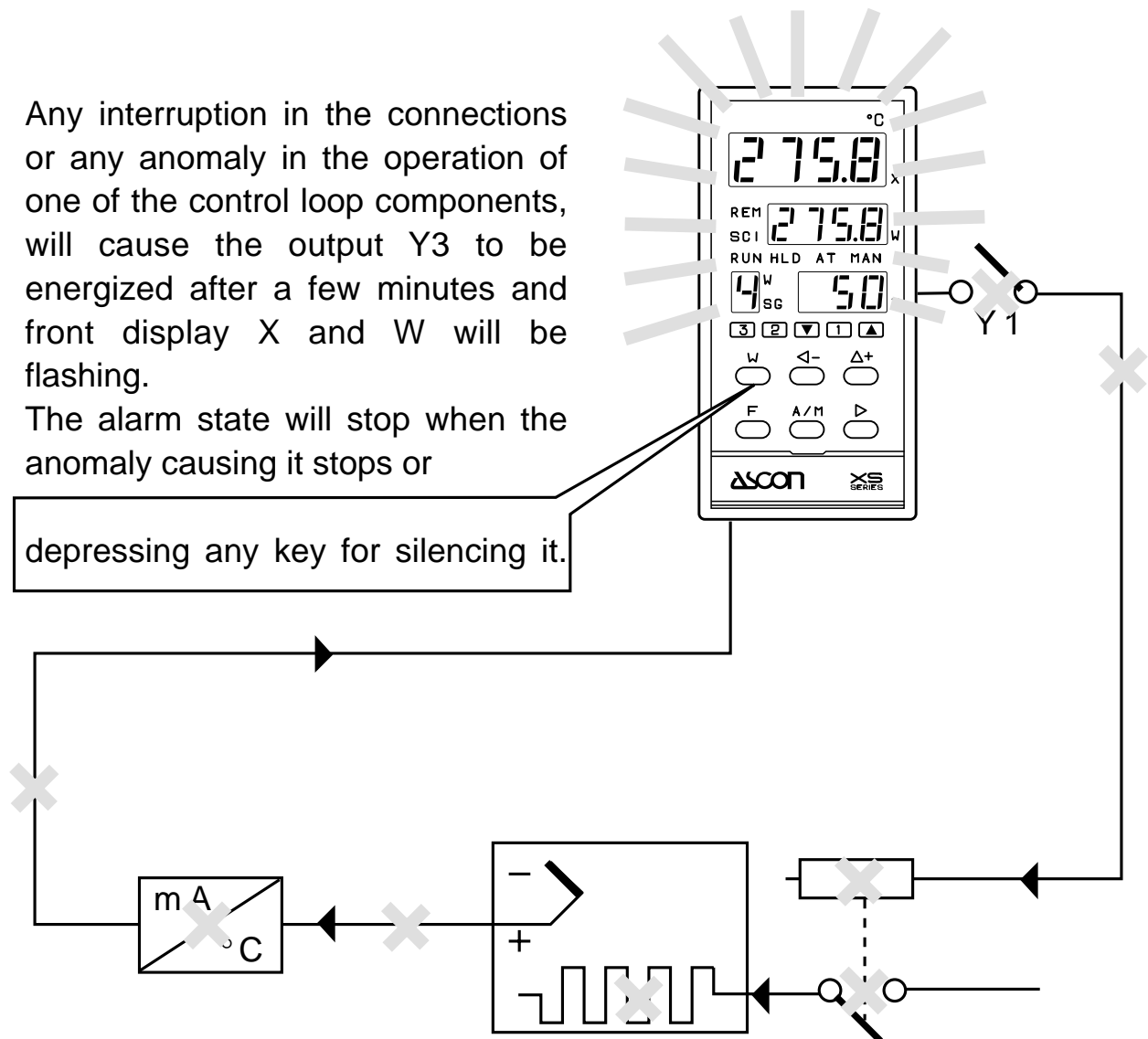

**With ON - OFF action "LBA" feature is not available**

### Time-programmable intervention

Only available with the Programmable Set point option.

The ON or OFF state of the auxiliary outputs Y2 and/or Y3 can be selected for every segment of the programme.

(See chapter 11)

## 6 • PASSWORD

In order to prevent tampering or inadvertent alterations of the configuration or of some important parameters at the programming stage, 2 passwords have to be entered.

### 6.1 Password of access to configuration 3333

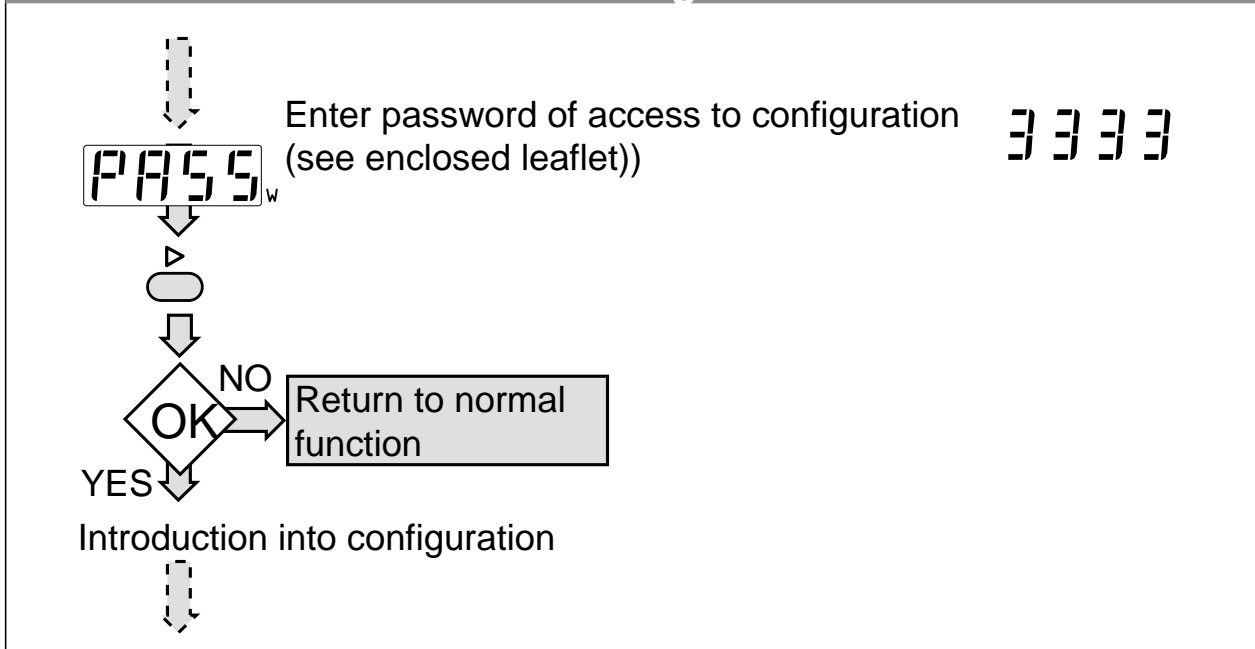

### 6.2 Password of access to the 5<sup>th</sup> parameter group 1111

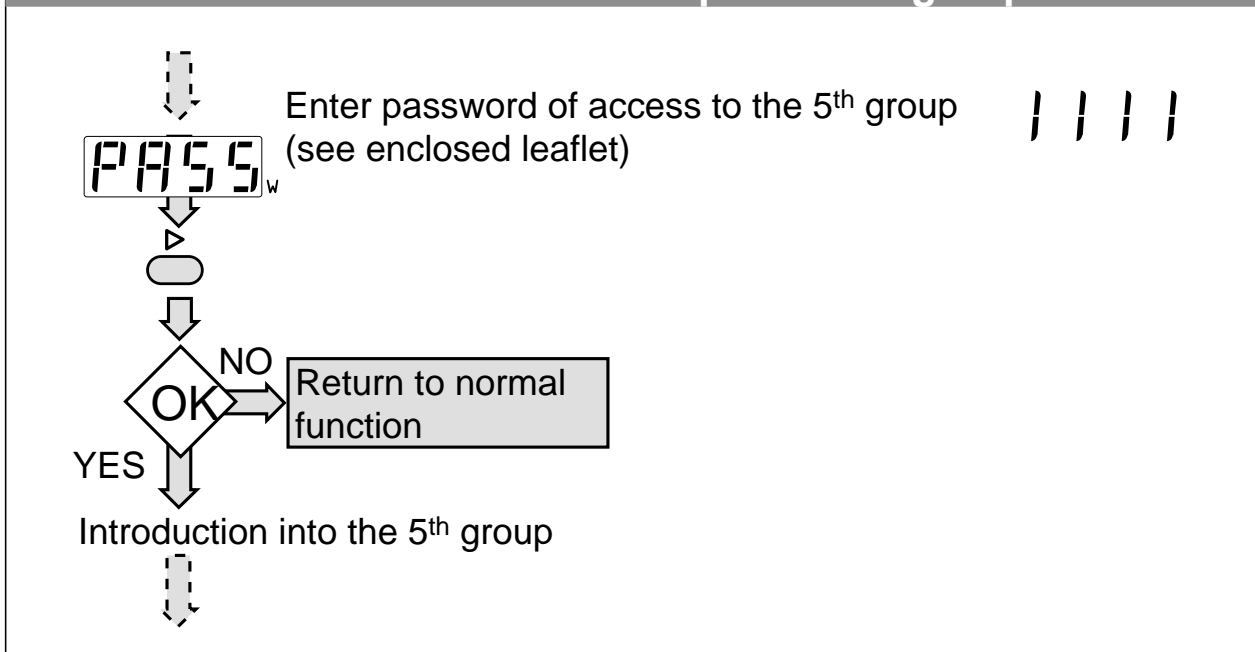

# 9 • MODIFYING THE OPERATING STATE

Modifications may be carried out through:

commands from keyboard

external contacts on logic inputs

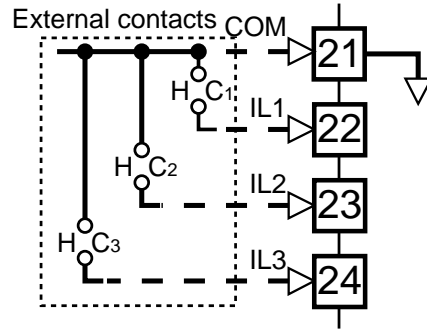
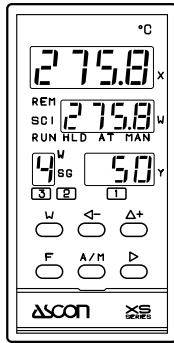

commands via serial

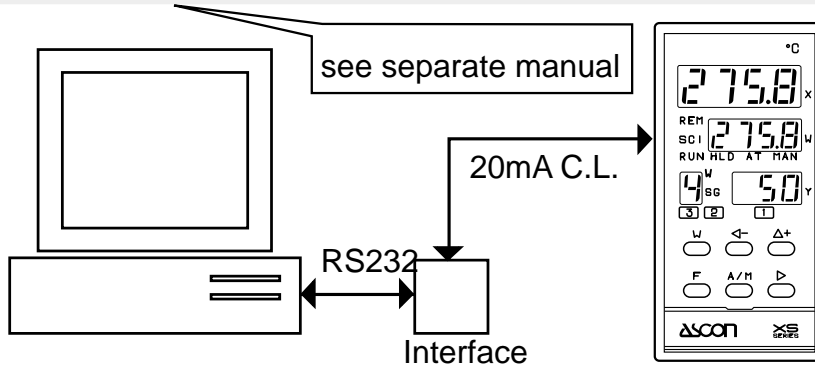

With external contacts on logic inputs IL1, IL2, IL3

Impulsives closing for at least 2 sec., of contacts C1, C2, C3, permits modification of state or of Set point.

IL1	IL2	IL3	Type of modification			
$\overline{C1}$	$\overline{C2}$	$\overline{C3}$	Version with standard Set point (note1) 1 Local + 4 Memorized	Version with standard Set point 1 Local + 1 Remote	Version with programmable Set point (option)	
			No action			
ON			Passage from REMOTE to LOCAL			
	ON		Passage from AUTOMATIC to MANUAL			
ON	ON		Passage from MANUAL to AUTOMATIC			
		ON	Local Sp. = Memorized Sp. 1	passage Local Sp. to Remote Sp.	Programme startup	RUN
ON		ON	Local Sp. = Memorized Sp. 2	—	Passage to successive segment (NEXT)	
	ON	ON	Local Sp. = Memorized Sp. 3	—	Temporary stop of programme	HLD
ON	ON	ON	Local Sp. = Memorized Sp. 4	—	Restart after stop of programme	

**Note 1:** Is possible to fix the selected Set point holding closed the relative contacts. While they are closed is possible to make changment from Auto/Man or Man/Auto but it is not possible to change Set point

## 12 • TECHNICAL DATA

<b>Accuracy</b> (a25°C amb.)	0.2% ± 1 digit (for input with RTD Pt100 and thermocouples)		
	0.1% ± 1 digit (for input in current and voltage)		
<b>Input "X"</b> (configurable)	RTD Pt100	Pt100Ω @ 0°C, (IEC 751)	With configurable scale field
	Thermocouples	J-K-S-R (IEC 584), L (DIN 43710)	
	Continuous current	4..20mA, 0..20mA, Ri 30Ω	
	Continuous voltage	0..1Vdc, 0..10Vdc, Ri 10KΩ	
<b>Auxiliary inputs</b>	3 of logic type (control of operating and Set point states)		
<b>Set point</b> (standard version)	1 Local + 4 storable		
	Distinct ascent and descent gradient slope	0.1...120.0% scale/min. or step gradient	
	Higher and lower limit	from beginning to end of scale	
programmable <b>Set point</b> (option)	from 3 to 11 segments (1 initial and 1 final)		
	Segment duration	from 0.1 to 540 min. (about 9 h.) 0...9999 min (on request)	
	Number of repetitions	1..9999	
Local/Remote <b>Set point</b>	In current	4..20mA, Ri30Ω	Not isolated accuracy: 0.1% at 25°C.
	In voltage	0..10Vdc, Ri 330kΩ	
<b>Control mode</b>	Algorithm	PID, PI, PD, P or On - Off	
	Proportional band (P)	0,5..999.9%	
	Integral action time (I)	0.1..100min., excludable	
	Derivative action time (D)	0.01..10min., excludable	
	Cycle time	1..200 sec. (for discontinuous control)	
	Hysteresis	0.1..10% (for on-off control)	
	Feed-Forward action	0..500% excludable scale span	
	Approach High and Low	0.01..twice the proportional band	
	Dead zone	±0.0...5% for dual action (heat-cool) control	
<b>Auto - Tune</b>	For automatic parameter adjustment (One shot)		
<b>Expert - Tune</b>	For continuous optimization of the parameters during normal operation.		
<b>Auto/Man Station</b>	With bumpless action, AUTO/MAN transfer via keyboard, logic input and serial communication.		

## 12 • TECHNICAL DATA

<b>Main output Y1</b> (configurable)	Single or dual, with direct or reverse action			
	Discontinuous	Relay with dual action 2 contacts NA, 5A/250Vac, 2x10 coeff.5 transitions		
		Logic	0.18 Vdc, 20mA max. (for static relays)	
	Continuous	Current	4..20mA(450Ω max., 10 Volts max.)	
		Voltage	0..10Vdc(450Ω min. 20 mA max.)	
Maximum output		10..100% (1 <sup>st</sup> channel $\triangle$ ) -10..-100% (2 <sup>nd</sup> channel $\nabla$ )		
<b>Auxiliary outputs Y2 - Y3</b> (configurable)	Relay	2 contacts NA, 5A/250Vac, 2x10(coeff.5) transitions		
	Action mode	active high (above the set point) active low (below the set point)		
	Hysteresis	0,1..10%		
	Type of Set point	deviation	$\pm$ 300 steps (with or without inhibited startup)	
		band	0..300 steps	
		independent	from beginning to end of scale	
Special functions	Loop-Break-Alarm (signal of control loop defect)			
	time-programmable (only for Set programmable option)			
<b>Retransmission output Y4</b> (option)	Current	4..20mA(450Ω max., 10Vdc max.)		
	Voltage	0..10Vdc(500Ω min., 20mA max.)		
		galvanically isolated		
<b>Serial communication</b> (option)	Interface 20mA C.L. passive and galvanically isolated For other data, see manual MIU, XS-CS/E			
<b>Protections</b>	Access to parameters	On three levels for: modification, indication only, no access		
	Immunity to disturbances	level IV, standard IEC 801-4		
	All significant data are stored in a non-volatile memory			
<b>Single power supply</b>	Standard model	100..240V, 48..63Hz, -15% + 10% 250 Vac max		
	Low voltage model	24V, 48..63Hz, -15% + 10% or 24Vdc $\pm$ 15%		
	Absorbed power	about 4VA		
<b>Auxiliary power supply</b>	24Vdc $\pm$ 10%, 20mA max. for 2-wire or 3 or 4-wire transmitter			
<b>General features</b>	Isolation group	C according to VDE 0110		
	Climatic group	KWF according to DIN 40040		
	Ambient temperature	0..50°C., humidity 35...85uR%		
	Protection	Front: IP54 standard (IP65 with Kit AXIP65- 1) Cover: IP30, terminal board IP20		
	Material	Self-extinguishing UL94V1		
	Weight	about 480 g.		
	Dimensions	48 x 96, depth 150mm, according to DIN 43700		

## GUARANTEE

The equipment is guaranteed free from manufacturing defects for 1 year after installation, for a maximum of 18 months after delivery.

Faults caused by use other than that described in these operating instructions are excluded from the guarantee.

### **ASCON spa**

20021 Bollate (Milano), Italy

Via Falzarego, 9/11 - Tel. (0039 - 2) 33337.1

Fax (0039 - 2) 3504243 - Telex 322451 ASCON I