

Configurable Multi-input, Multi-set point Controller for Servomotors

XP Series



INSTRUCTION MANUAL

MIU.XP-5/96.12/E

COD. J30 154 1AXP ING

ASCON spa

GENERAL INDEX

1	IDENTIFICATION OF MODEL	pag. 1
2	FUNCTION OF KEYS AND DISPLAYS	pag. 3
3	DIMENSIONS, INSTALLATION	pag. 6
4	ELECTRICAL WIRING	pag. 7
5	Y2 - Y3 AUXILIARY OUTPUTS	pag. 12
6	PASSWORDS	pag. 14
7	PROGRAMMING PROCEDURE (see enclosed leaflet) CONFIGURATION PARAMETERS	
8	OPERATING DIRECTIONS (see enclosed leaflet) SET POINT AUTO/MAN LOC/REM AUTO-TUNE	
9	MODIFYING THE OPERATING STATE	pag. 15
12	TECHNICAL DATA	pag. 16

SERIAL COMMUNICATIONS
(see the instruction manual "SERIAL COMMUNICATION
SUPPLEMENT" supplied separately)

1 • IDENTIFICATION OF MODEL

Thank you for choosing an ASCON controller

The instruments of the XP series belong to the last generation of microprocessor based controller, are universal, very powerful but simple to use.

They are fitted with AUTO-TUNE, as aid for system start-up, and serial communication for introduction into a distributed control network.

They are complete because all possible variables are always present. Configuration of the instrument permits determination of the operating mode according to the application required.

1.1 Identification of model

Model code

XP - **A B C D /**

Configuration code

Beginning and end of scale

OPTIONS	Power supply	A
	100 ...240 V 50/60 Hz	3
	16 ...28 V 50/60 Hz and 20...30 Vdc	5
	Serial communications	B
	None	0
	20mA C.L. Std Ascon protocol	1
	20mA C.L. Modbus/Jbus protocol	2
	Retransmission output Y4	C
	None	0
	Fitted (4...20 mA or 0...10 Vdc)	1
	Set point	D
	Standard (up to 4 mem. or Loc./Rem.)	0
	Time-programmable (11 segments)	1

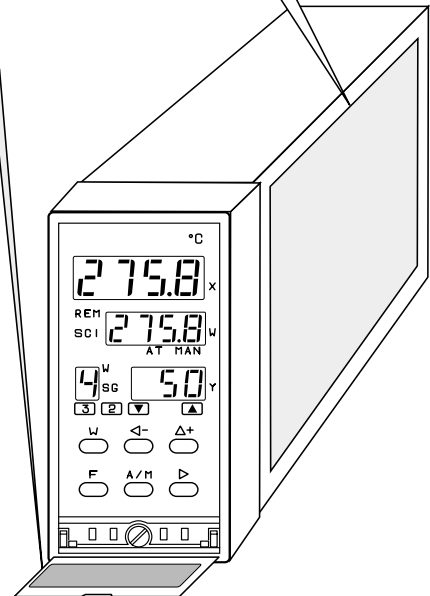

1 • IDENTIFICATION OF MODEL

1.2 Configuration code

Configuration code Beginning and end of scale

EF5H - ILMN / O P

Model code

1st part	Input X	E
	Main output Y1	F
2nd part	Auxiliary output Y2	5
	Auxiliary output Y3	H
	Retransmission output Y4	I
	Set point W	L
Beginning and end of scale (for configurable scales only))		M
		N
		O
		P

The controller is normally configured in the factory.

If this appears at the power-up



the controller **IS NOT CONFIGURED**

In order to configure the controller, follow the configuration procedure reported in the enclosed leaflet

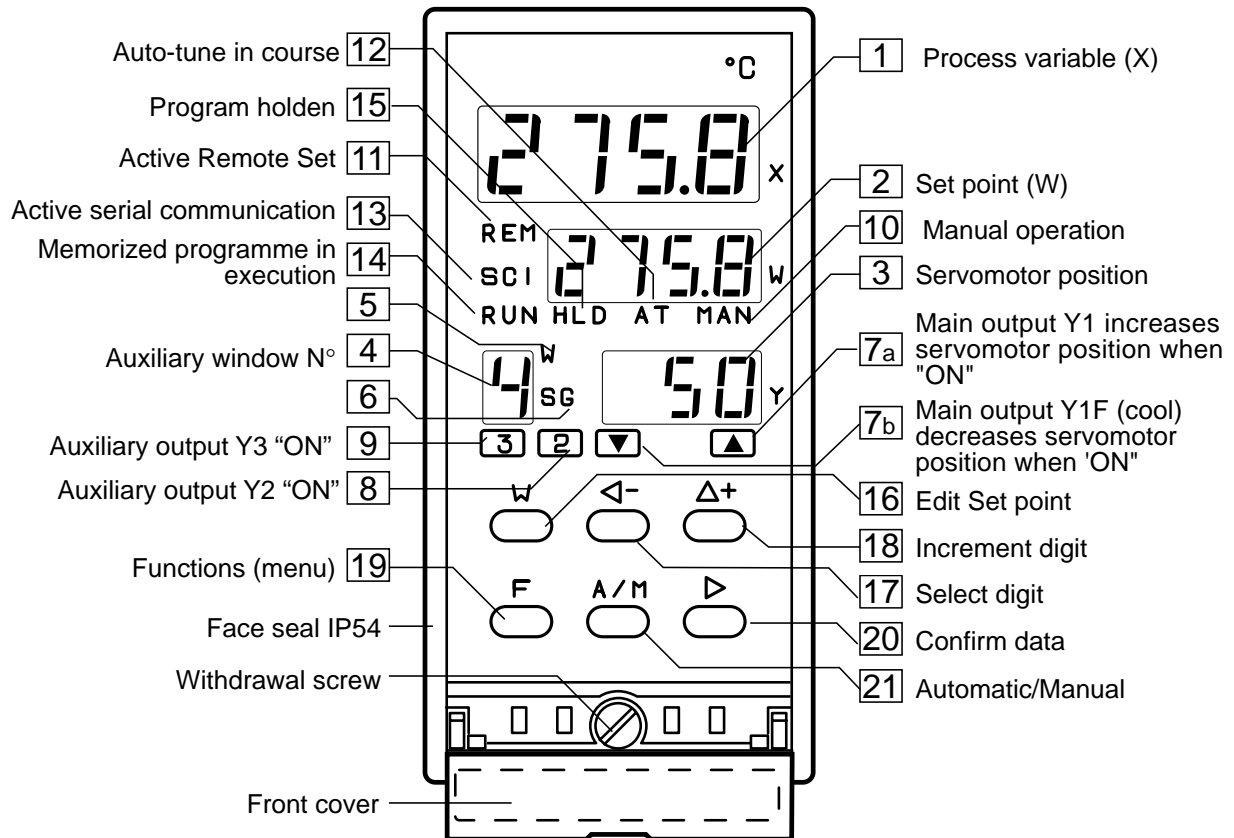
2 • FUNCTION OF KEYS AND DISPLAYS



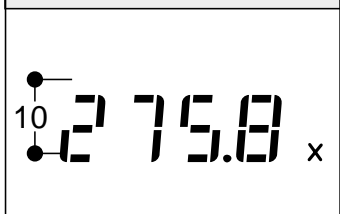

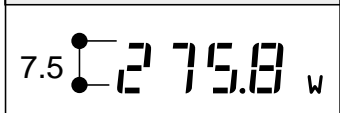
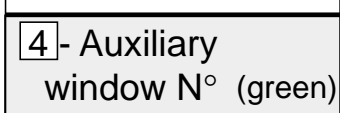
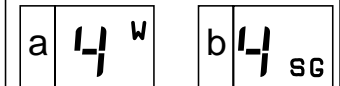

NUMERIC INDICATORS X, W, Y, N°

<p>1- Process variable (X) (green)</p>	<p>The value of measure X is expressed in engineering units.</p>
	<p>If above end of scale </p> <p>If below beginning of scale </p> <ul style="list-style-type: none"> - In programming: displays parameter values - In configuration: displays the values of the 1st part of the configuration code (see enclosed leaflet)
<p>2- Set point (W) (green)</p>	<p>Displays the operating Set point value (Local or Remote)</p>
	<ul style="list-style-type: none"> - In programming: displays the parameter codes - In configuration: displays the index values of the 2nd part of the configuration code (see enclosed leaflet)
<p>3- Output Y1 (green)</p>	<p>Displays the value of servomotor position from 0...100%</p> <ul style="list-style-type: none"> - In configuration: Displays the mnemonic code $\square \square$
	<p>Normally off, lights up to display</p> <ul style="list-style-type: none"> a - the selected N° of 1 of the 4 stored Set points , in which case led 5 "W" lights up too b - the N° of the segment in execution (option with programmable set, see chapter 11) in this case, led 6 "SG" lights up too
	

2 • FUNCTION OF KEYS AND DISPLAYS





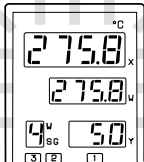

LEDS FOR OUTPUT STATE

7a - Output Y1 (increase)	Lit with output Y1 "ON" (increasing servomotor position)
	
7b - Output Y1 (decrease)	Lit with output Y1 "ON" (decreasing servomotor position)
	
8 - Output Y2 (red)	Lit with output Y2 "ON"
	
9 - Output Y3 (red)	Lit with output Y3 "ON"
	

LEDS FOR OPERATING STATE

10 - Manual (green)	Lit in Manual operation	
<i>MAN</i>		
11 - Remote (green)	Lit when the Remote Set point is operating (if off, the operating Set point is the Local one)	
<i>REM</i>		
12 - Auto-Tune (green)	Lit when Auto-Tune is in course	
<i>AT</i>		
13 - Serial comm. (green)	Permanently lit when the serial communication is enabled to write. Flashes with signal in transit	
<i>SCI</i>		
14 - In execution (green)	When lit indicates that the stored programme is in course	Only for instruments with time - programmable option
<i>RUN</i>		
15 - Program holden (green)	When lit indicates temporary suspension of the programme in course	
<i>HLD</i>		
Loop - Break - Alarm		With output Y3 active and configured as Loop Break Alarm, the front displays X and W are flashing (see p. 13)

2 • FUNCTION OF KEYS AND DISPLAYS

KEYS			
16 - Edit Set Point		<p>Standard configuration: (1 Local + 4 storable used for:</p> <ul style="list-style-type: none"> • modifying the Set point • recalling the 4 memorized Set points (see enclosed leaflet) <p>Remote Set configuration: (1 Local + 1 Remote) used for:</p> <ul style="list-style-type: none"> • passing from Local to Remote Set point and viceversa (see enclosed leaflet) <p>Programmed Set configuration: (see chapter 11)</p> <ul style="list-style-type: none"> • to recall the Local operating Set point • to start, stop, start again the execution of the memorized programme 	
17 - Digit selection		<p>Selects the digit to be modified (see enclosed leaflet) In Manual operation, decrements the value of main output Y1</p>	<p>Keys for modifying numeric values of any data</p>
18 - Increment digit		<p>Increments the value of the flashing digit, from 0 to 9 In manual operation increments the value of main output Y1</p>	
19 - Functions		<p>Permits access to menu of functions to be programmed</p>	<p>Keys for data programming and processing</p>
20 - Enter		<p>Enter or Scroll of values and modes of operation</p>	
21 - Auto/Man		<p>Passage from Automatic to Manual operation and viceversa</p>	

3 • DIMENSIONS - INSTALLATION

3.1 - Overall dimensions (in compliance with DIN 43700)

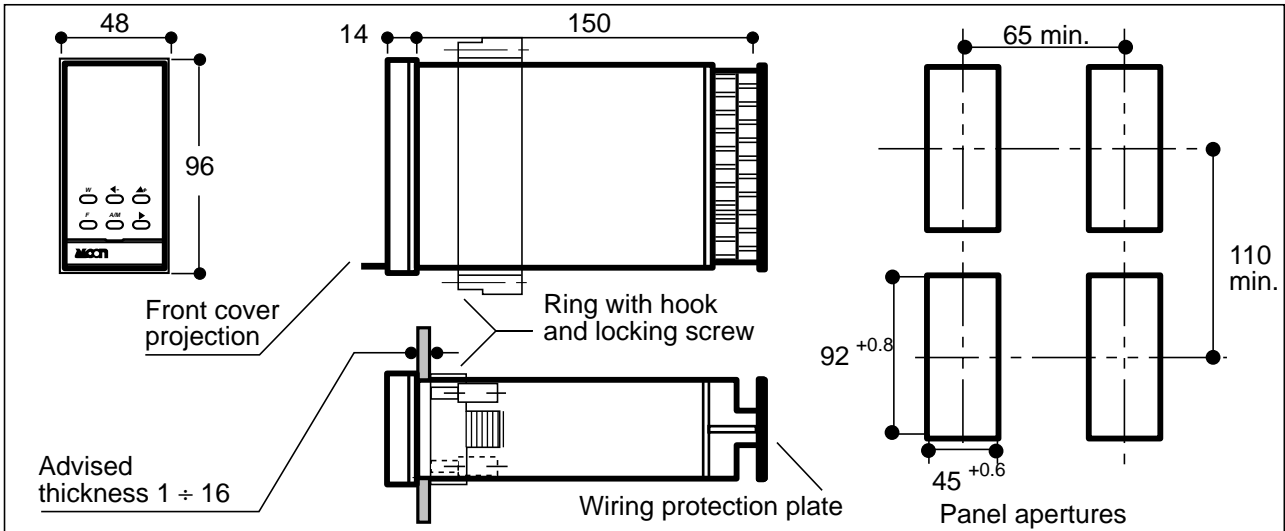

3.2 - Panel installation

A • Panel fitting

- Install away from:
- heat sources
 - corrosive gases
 - dusty environments

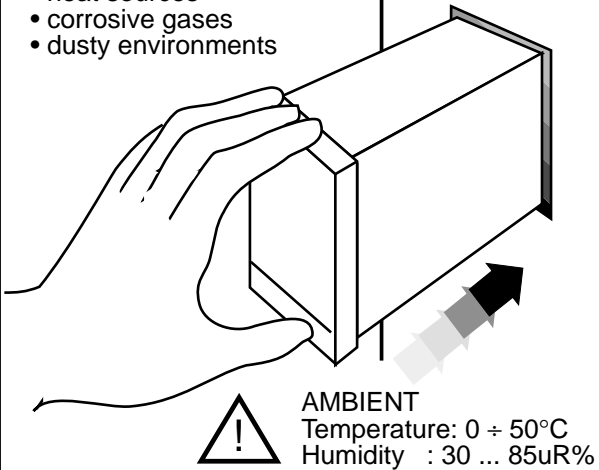

B • Fixing with ring

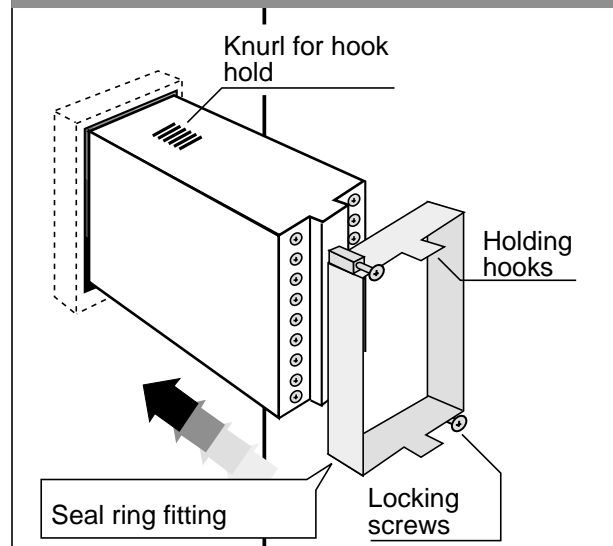

C • Screw locking

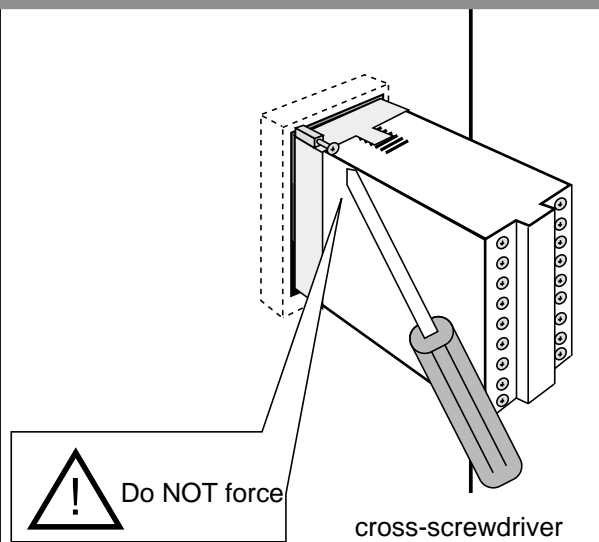

D • Plate for engineering units

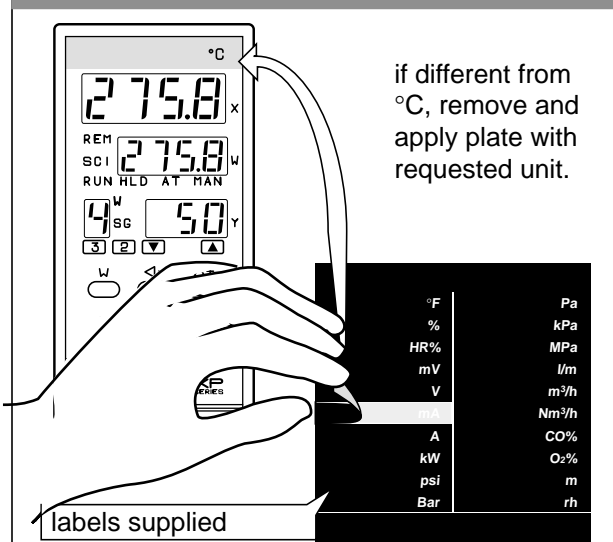

4 • ELECTRICAL WIRING

A • Terminal board

28 screw terminals M3.5

Plate pin

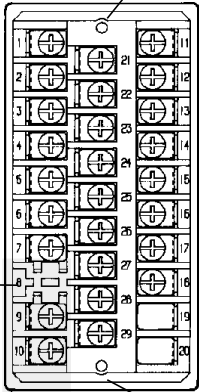

Wiring protection plate

Plate screw

Cold joint compensation thermometer

3 gilded terminals for input signals

B • Freeing the terminals

1 Lift the plate to free the pin

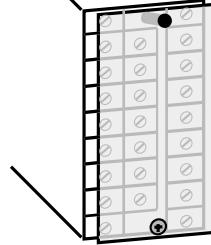

2 Rotate downwards

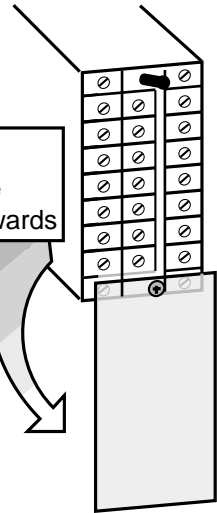

C • Effecting the connections

With eyelet terminals

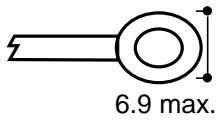

Cable section

wires N°

2

With fork terminals

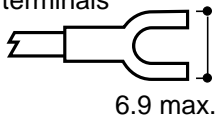

0.25 ÷ 2.5 AWG
22 ÷ 14

1

7

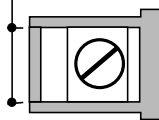

With tinned wire

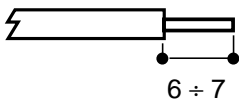

2

Preferential

D • Protecting the terminal board

1 Rotate upwards

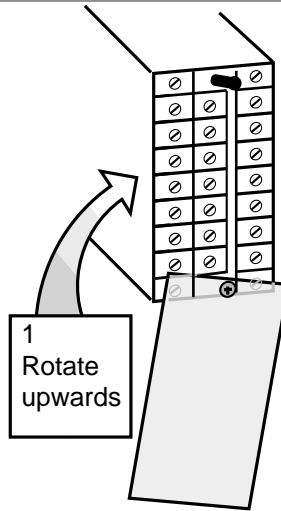

2 Depress the plate to engage the pin

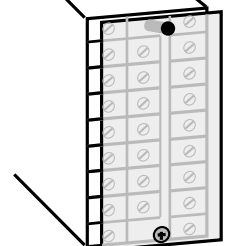

4 • ELECTRICAL WIRING

Although this controller is designed to resist the heaviest disturbances present in industrial environments (level IV of standard (IEC 801-4), it is advised to keep to the following precautions:

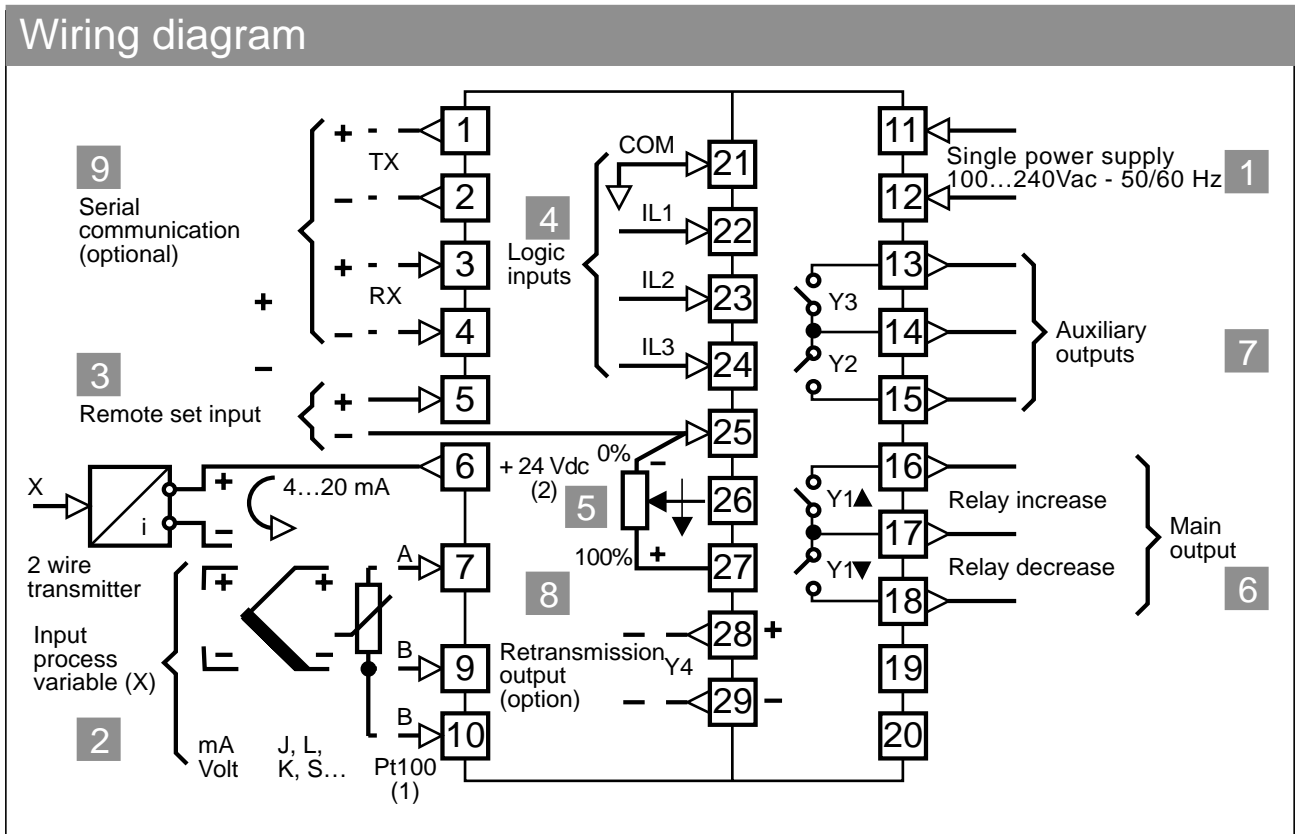
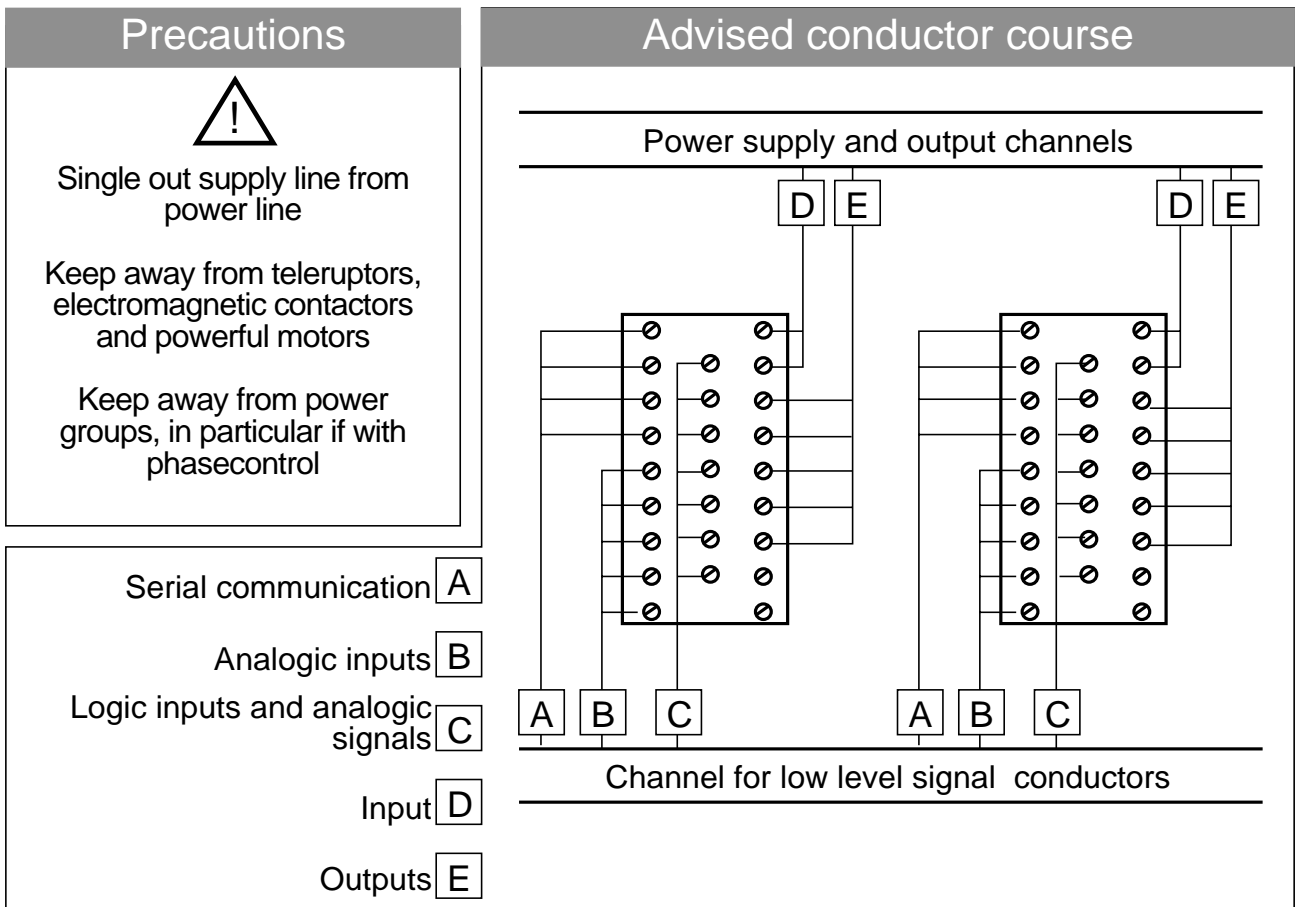

4 • ELECTRICAL WIRING

1 • Single power supply

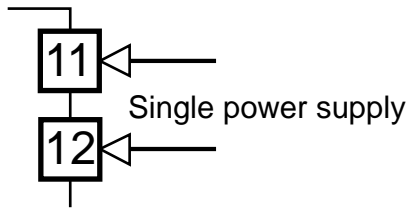

"Switching" type

- Standard: 100 to 240 Vac - 15% + 10%
- for low tension: 24 Vac -15% + 10%
- 24 Vdc \pm 15%

Absorbed power 4VA

2 • Process variable (X)

A - For thermocouples J-L-K-S-R

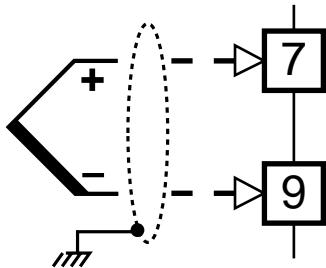

Line: max. 150 Ω

- Respect polarities
- For eventual extensions, use a compensated cable suitable for the type of thermocouple used
- The eventual shield must be well earthed at only one end

B - For RTD Pt100

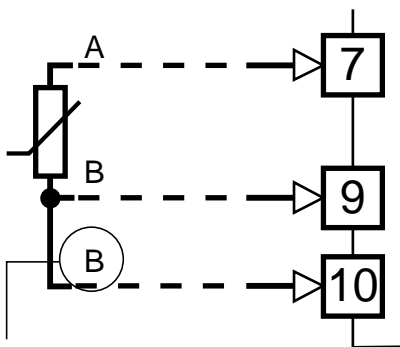

for 3-wire connection only
Line: max. 20 Ω per wire

- For 3-wire connection, use cables of same section (min. 1 sq.mm)
- For 2-wire connection, use cables of adequate section (min. 1.5 sq.mm.)

Note:

with a 15 mt. probe to controller distance and a 1.5 sq.mm. section cable, the error is about 1°C.

C • Continuous, mA, Volt

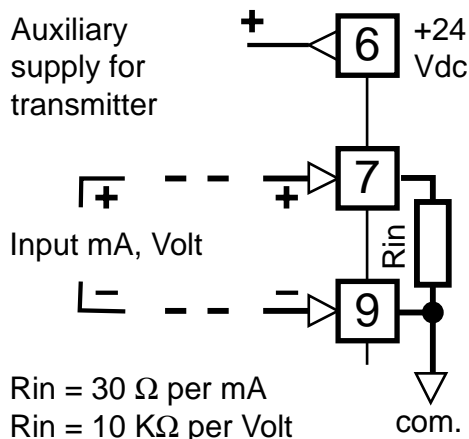

For 2-wire transmitter

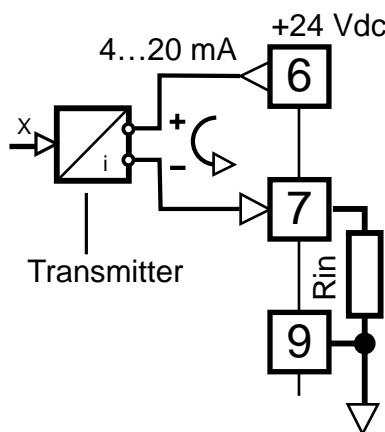

For 3 or 4-wire transmitter

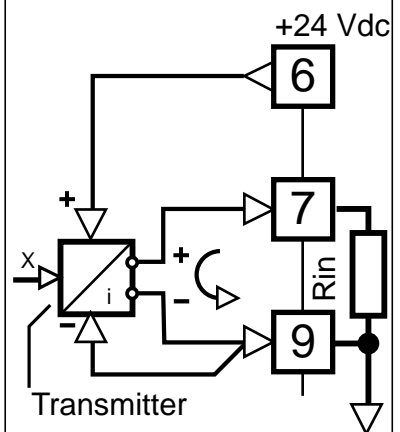

4 • ELECTRICAL WIRING

3 • Remote Set point input

Rin = 30 Ω per mA
Rin = 330 KΩ per V

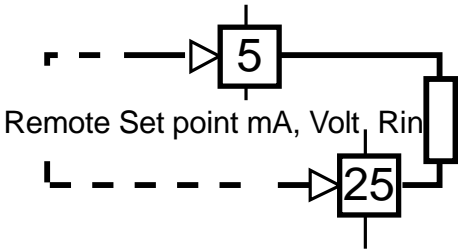

In current 4..20 mA

In voltage 0..10Vdc

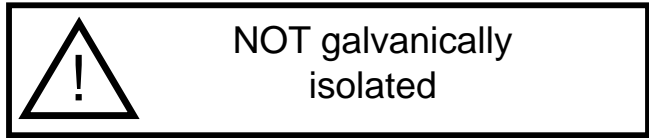

4 • Logic inputs

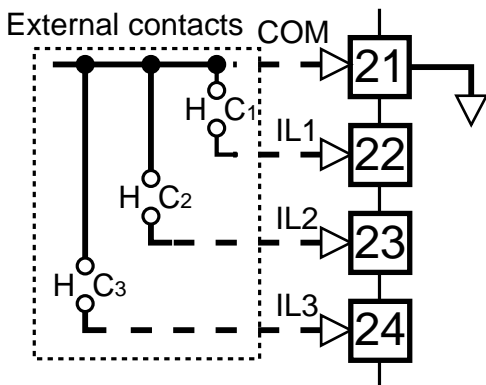

An impulsive (2 sec. at least) closing of contacts C1, C2, C3, permits the selection AUTO or MAN, Local or Remote Set point, recalling the 4 memorized Set points and launching of the programmed Set point. (see p. 14)

5 • Input potentiometer position

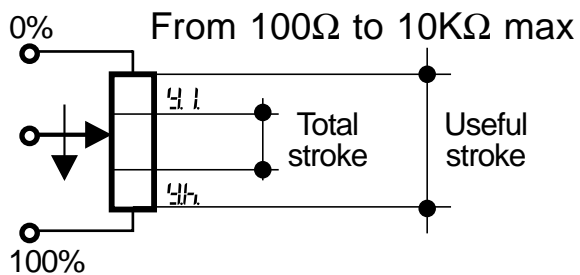
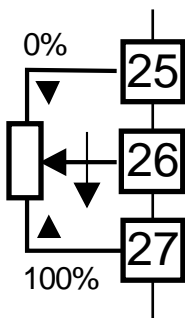

From 100Ω to 10KΩ max
See calibration procedure on the enclosed sheet

6 • Main output Y1

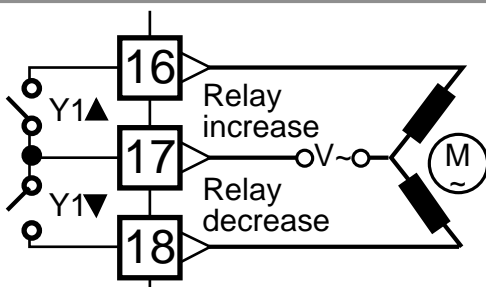

Three positions two interlocked NO contacts (Increase stop Decrease)
5A/250 Vac for resistive loads (transition 2 x 10⁵ min. at 5A/250 Vac)

4 • ELECTRICAL WIRING

7 • Auxiliary outputs Y2 - Y3 (see p. 12)

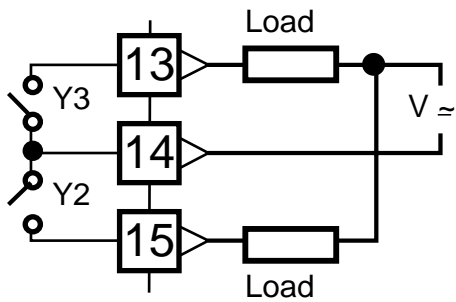

N0 contacts, capacity 5A/250Vac for resistive loads (transitions 2×10^5 min. at 5A/250Vac)

8 • Retransmission output Y4 (option)

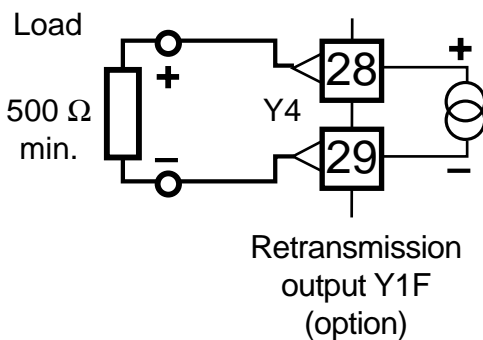

Retransmission:
of measurement X
of Set point W

Galvanically isolated
4..20mA, 10Vdc max. or
0..10Vdc, 20mA max.

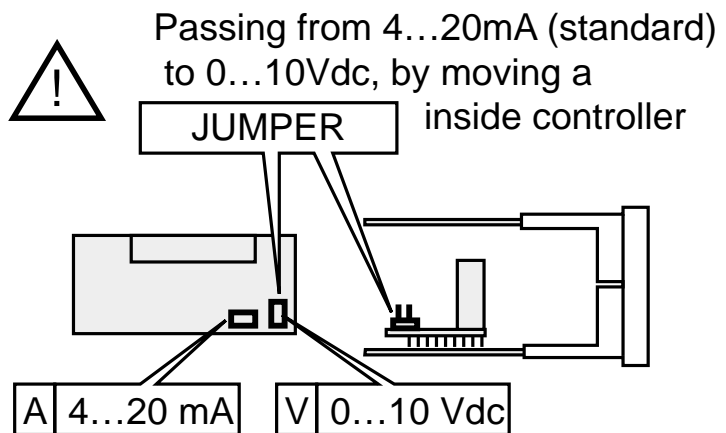

9 • Serial communication (option)

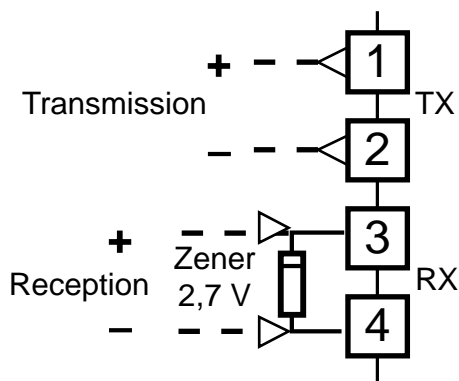

Interface 20mA C.L. passive and galvanically isolated

**Consult the instruction manual
"SERIAL COMMUNICATION
SUPPLEMENT"
supplied separately.**

5 • AUXILIARY OUTPUTS Y2 AND Y3

Deviation		
	Active high (above)	Set point ΔW (1) -300...+300 units compared to W1
	Active low (under)	
Band		
	Active Out	Set point I $\Delta W I$ (1) -0...300 units compared to W1
	Active In	
Independent		
	Active high (above)	Set point (1): from beginning to end of scale
	Active low (under)	

(1) The Set point of Y2 and Y3 is not limited by the limits of the main Set point W1, but only by the scale span.

Deviation with startup inhibition

	Active high (above)	Set point ΔW (1) -300...+300 units compared to W1
	Active low (below)	

5 • AUXILIARY OUTPUTS Y2 AND Y3

“Loop-Break-Alarm” LBA (control loop defect/interruption)

Any interruption in the connections or any anomaly in the operation of any of the control loop components, will cause the output Y3 to be energized after a few minutes and front display X and W will be flashing.

The alarm state will stop when the anomaly causing it stops or

depressing any key for silencing it.

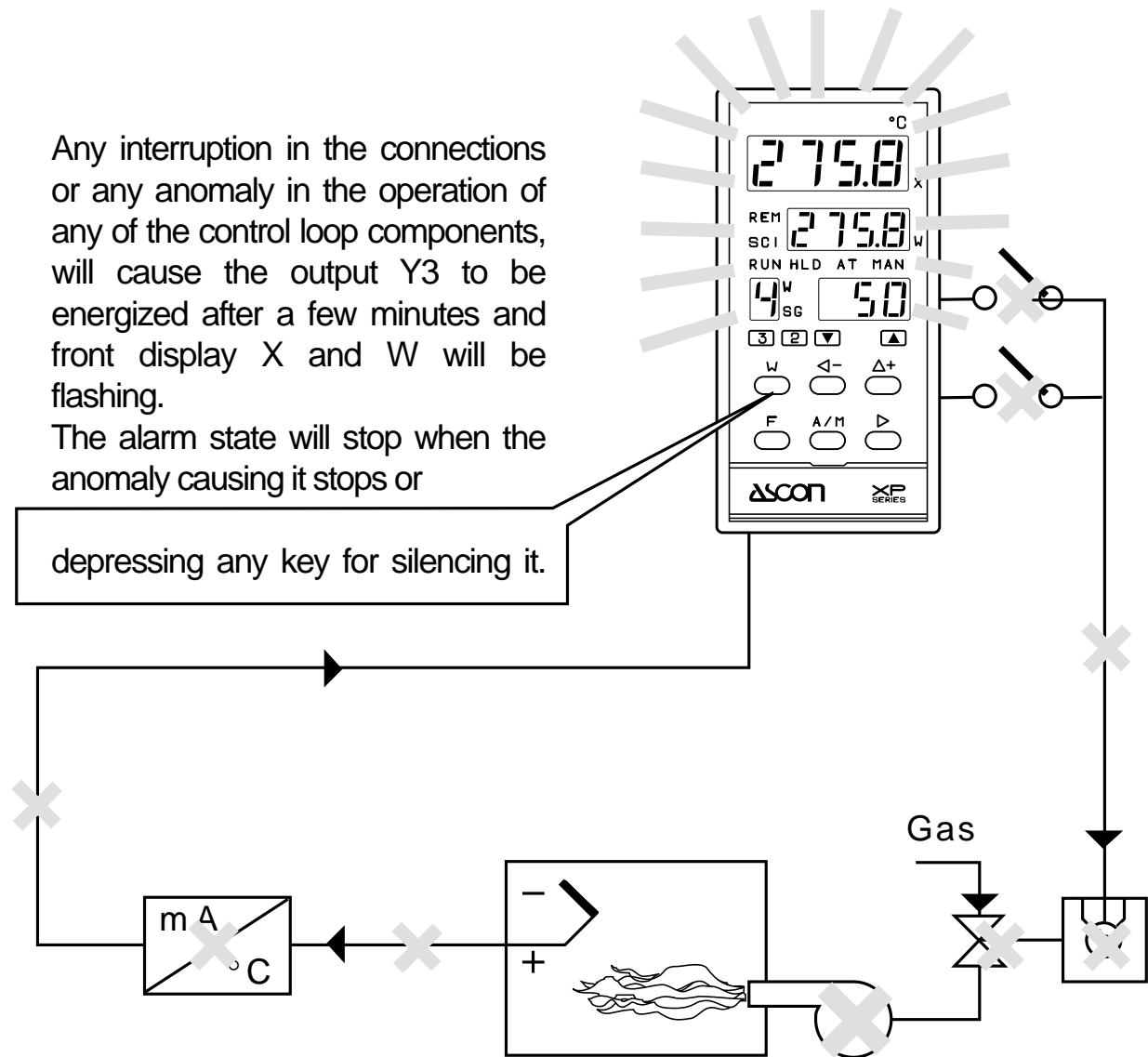

With ON - OFF action "LBA" feature is not available

Time-programmable intervention

Only available with the Programmable Set point option.

The ON or OFF state of the auxiliary outputs Y2 and/or Y3 can be selected for every segment of the programme.

(See chapter 11)

6 • PASSWORDS

In order to prevent tampering or inadvertent alterations of the configuration or of some important parameters at the programming stage, 2 passwords have to be entered.

6.1 Password of access to configuration 3333

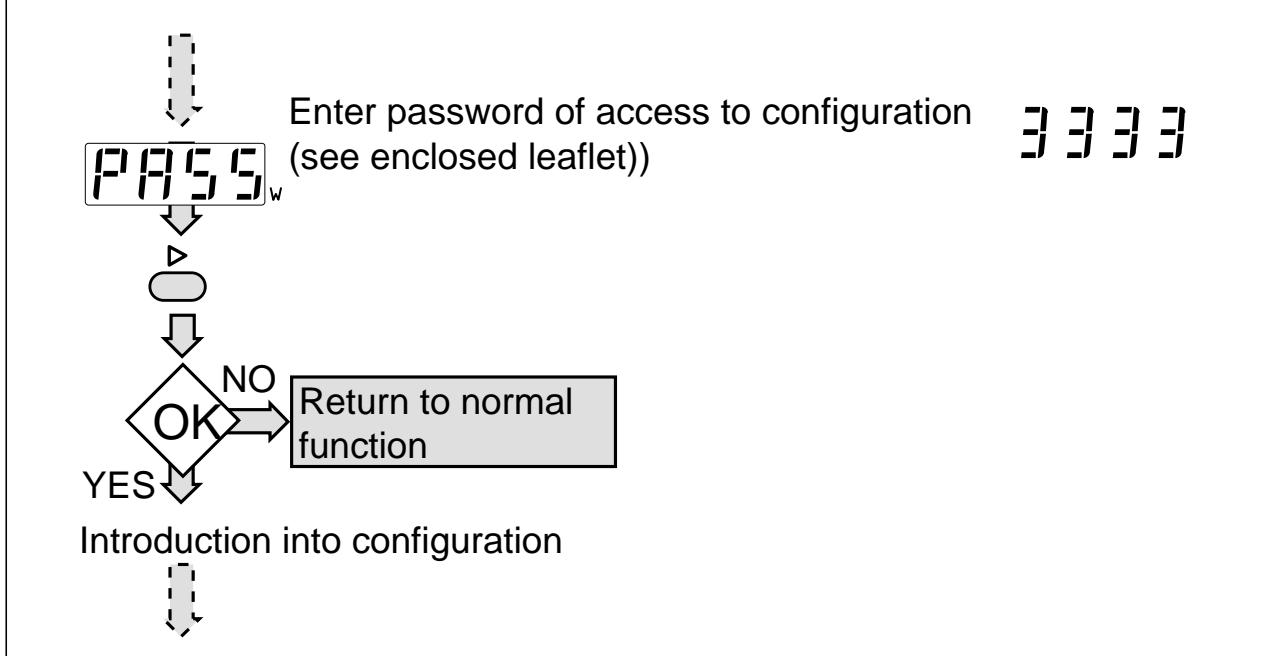

6.2 Password of access to the 5th parameter group 1111

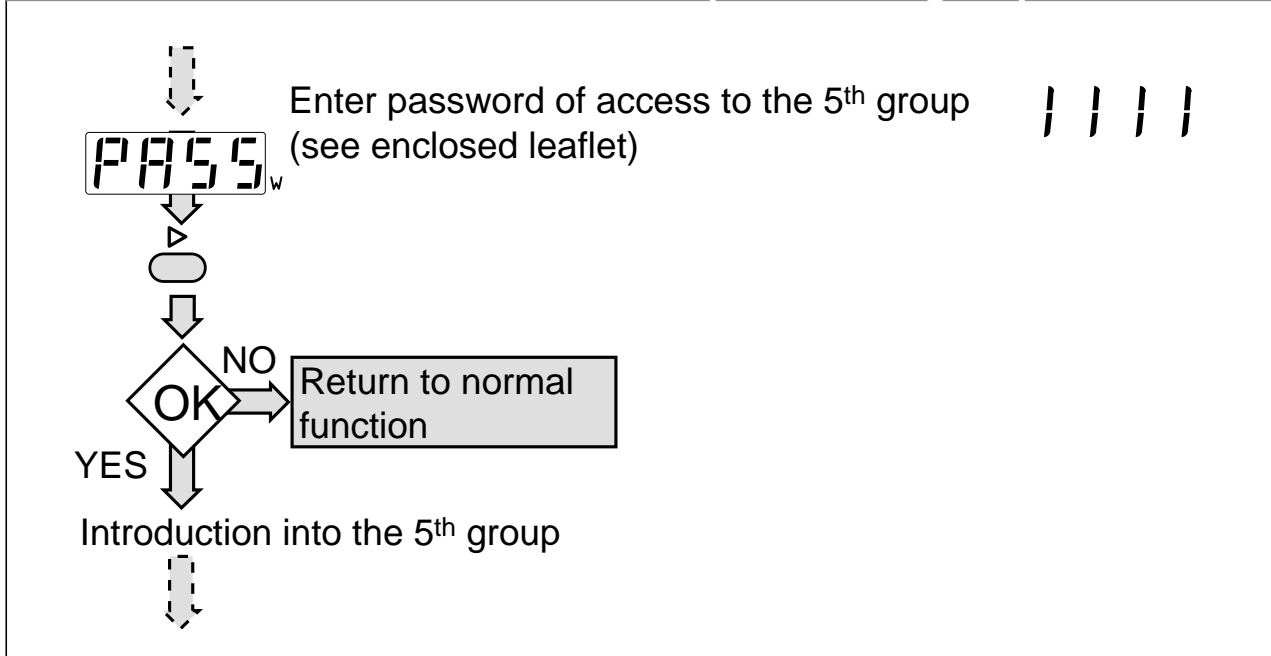

9 • MODIFYING THE OPERATING STATE

Modifications may be carried out through:

commands from keyboard

external contacts on logic inputs

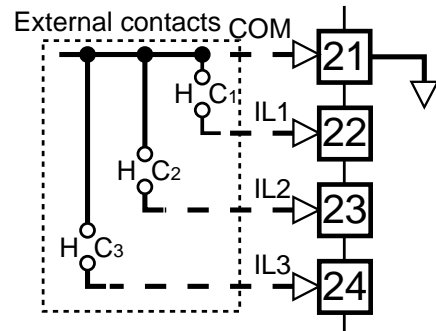
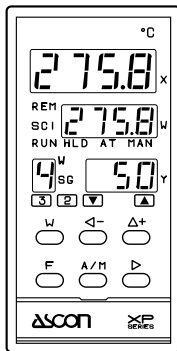

commands via serial

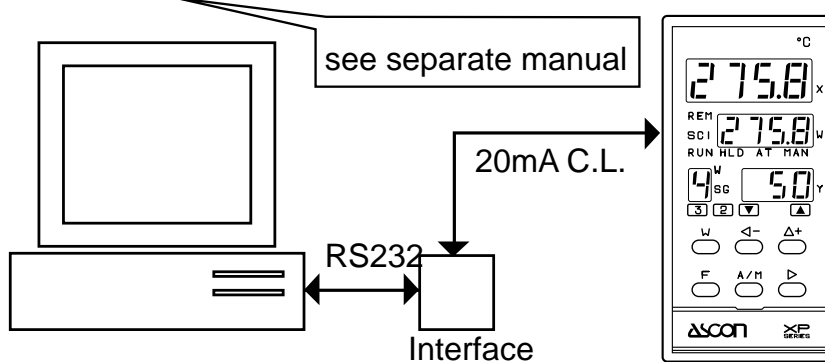

With external contacts on logic inputs IL1, IL2, IL3

Impulsives closing for at least 2 sec., of contacts C1, C2, C3, permits modification of state or of Set point.

IL1	IL2	IL3	Type of modification			
$\overline{C1}$	$\overline{C2}$	$\overline{C3}$	Version with standard Set point (note1) 1 Local + 4 Memorized	Version with standard Set point 1 Local + 1 Remote	Version with programmable Set point (option)	
			No action			
ON			Passage from REMOTE to LOCAL			
	ON		Passage from AUTOMATIC to MANUAL			
ON	ON		Passage from MANUAL to AUTOMATIC			
		ON	Local Sp. = Memorized Sp. 1	passage Local Sp. to Remote Sp.	Programme startup	RUN
ON		ON	Local Sp. = Memorized Sp. 2	—	Passage to successive segment (NEXT)	
	ON	ON	Local Sp. = Memorized Sp. 3	—	Temporary stop of programme	HLD
ON	ON	ON	Local Sp. = Memorized Sp. 4	—	Restart after stop of programme	

Note 1: Is possible to fix the selected Set point holding closed the relative contacts. While they are closed is possible to make changment from Auto/Man or Man/Auto but it is not possible to change Set point

12 • TECHNICAL DATA

Accuracy (25°C. amb.)	0.2% ± 1 digit (for input with RTD Pt100 and thermocouples)		
	0.1% ± 1 digit (for input in current and voltage)		
Process variable (configurable)	RTD Pt100	Pt100 (IEC 751)	With configurable scale field
	Thermocouples	J-K-S-R (IEC 584), L (DIN 43710)	
	Direct current	4..20mA, 0..20mA, Ri 30Ω	
	Direct voltage	0..1Vdc, 0..10Vdc, Ri 10KΩ	
Auxiliary inputs	3 of logic type (control of operating and Set point states)		
Set point (standard version)	1 Local + 4 storable		
	Distinct ascent and descent gradient slope	0.1...120.0% scale/min. or step gradient	
	Higher and lower limit	from beginning to end of scale	
Programmable Set point (option)	from 3 to 11 segments (1 initial and 1 final)		
	Segment duration	from 0.1 to 540 min. (about 9 h.) 0...9999 min (on request)	
	Number of repetitions	1..9999	
Local/Remote Set point	Current	4..20mA, Ri30Ω	Not isolated accuracy: 0,1% a 25°C
	Voltage	0..10Vdc, Ri 330kΩ	
Control mode	Algorithm	Floating positioning P.I.D.	
	Proportional band (P)	0,5..999,9%	
	Integral action time (I)	0,1..100min., excludable	
	Derivative action time (D)	0,01..10min., excludable	
	Feed Forward action	0..500% excludable scale span	
	Approach High and Low	0.01..twice the proportional band	
	Dead zone	Actuator positioning resolution 0.1...10,0%	
Auto - Tune	For automatic parameter adjustment (One shot)		
Auto/Man Station	With bumpless action, AUTO/MAN transfer via keyboard, logic input and serial communication.		

12 • TECHNICAL DATA

Main output Y1	Three states: Increase - stop - Decrease		
	Interlocked contacts "NO" 5A/250 Vac, 2x10 ⁵ operations		
	Direct or inverse action selectable		
Auxiliary outputs Y2 - Y3 (configurable)	Relay	2 contacts NO, 5A/250Vac, 2x10 ⁵ transitions	
	Action mode	active high (above the set point) active low (below the set point)	
	Hysteresis	0,1..10%	
	Type of Set point	deviation	± 300 steps (with or without inhibited startup)
		band	0...300 steps
		independent	from beginning to end of scale
Special functions	Loop-Break-Alarm (signal of control loop defect)		
	time-programmable (only for Set programmable option)		
Retransmission output Y4 (option)	Current	4..20mA (450Ω max, 10Vdc max)	galvanically isolated
	Voltage	0..10Vdc (500Ω min, 20mA max)	
Serial communication (option)	Interface 20mA C.L. passive and galvanically isolated For other data, see manual		
Protections	Access to parameters	On three levels for: modification, indication only, no access	
	Immunity to disturbances	level IV, standard IEC 801-4	
	All significant data are stored in a non-volatile memory		
Single power supply	Standard model	100..240V, 48..63Hz, -15% + 10% 250Vac max	
	Low voltage model	24V, 48..63Hz, -15% + 10% or 24Vdc ± 15%	
	Absorbed power	about 4VA	
Auxiliary power supply	24Vdc ± 10%, 20mA max. for 2-wire or 3 or 4-wire transmitter		
General features	Isolation group	C according to VDE 0110	
	Climatic group	KWF according to DIN 40040	
	Ambient	temperature 0...50°C., humidity 35...85uR%	
	Protection	Front:IP54 standard (IP65 with Kit AXIP65- 1) Cover: IP30, terminal board IP20	
	Material	Self-extinguishing 94V1	
	Weight	about 480 g.	
	Dimensions	48 x 96, depth 150mm, according to DIN 43700	

GUARANTEE

The equipment is guaranteed free from manufacturing defects for 1 year after installation, for a maximum of 18 months after delivery.

Faults caused by use other than that described in these operating instructions are excluded from the guarantee.

ASCON spa

20021 Bollate (Milano), Italy

Via Falzarego, 9/11 - Tel. (0039 - 2) 33337.1

Fax (0039 - 2) 3504243 - Telex 322451 ASCON I