

7 • PROGRAMMING INSTRUCTIONS • XF SERIES CONTROLLERS

FUNCTIONS MENU

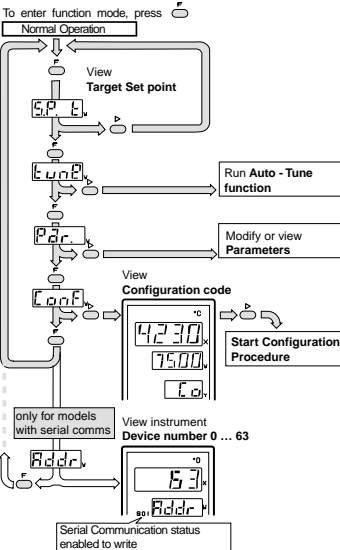
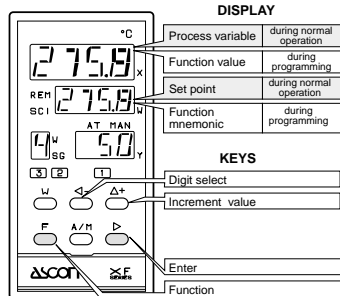

Note:
 1 If **F** or **B** is not pressed within 10 seconds the instrument will time-out back to the process variable.
 2 If **5L.u = 5L.d = 0**, will not appear.

CONFIGURATION

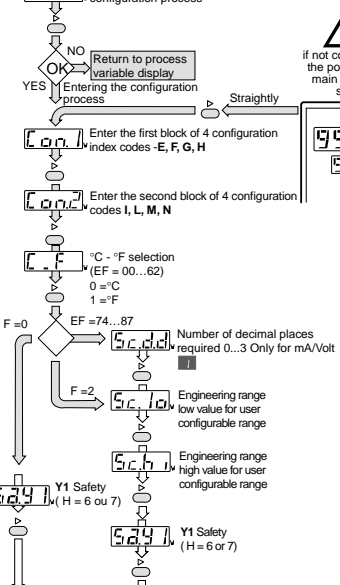

To the 3rd group parameters
 Exiting the configuration process you will access straightly the 3rd group of parameters to modify. If necessary, Set point limits, maximum power output etc...

GROUP 1

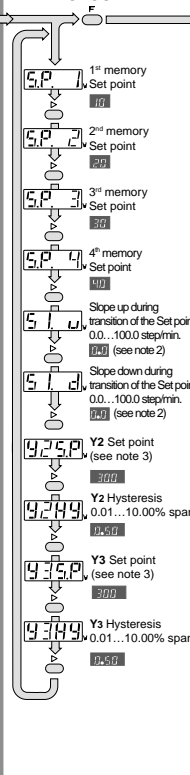

Note:
 1 The 4 memory set point will only be shown if configuration code N=3
 2 If slope gradient = 0 there will be a step change
 3 Allowable Set point values depend upon the type of alarm configuration
 • Deviation alarm : -300...+300
 • Band alarm : 0...300
 • Independent : on full scale
 4 Parameters Y2 and Y3 will not appear if in the configuration code (I = 0 and L = 0)

PARAMETERS

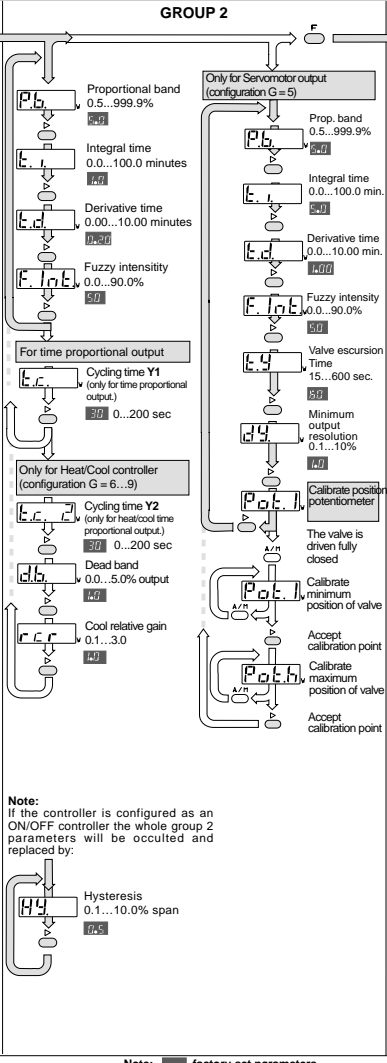

Note:
 If the controller is configured as an ON/OFF controller the whole group 2 parameters will be occulted and replaced by:

Hysteresis
 0.1...10.0% span
 0.5

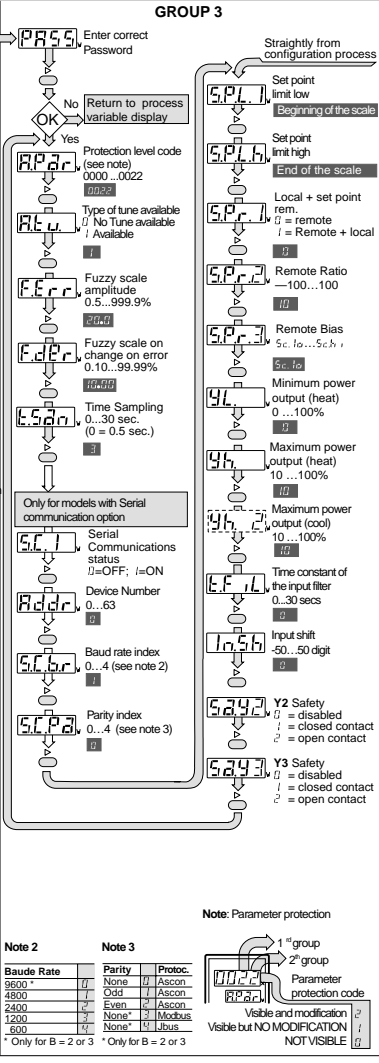

Note 2:

Baud Rate	Parity	Protoc.
9600	0	Ascon
4800	0	Ascon
2400	0	Ascon
1200	0	Modbus
600	0	Modbus

Note 3:

1 st group	2 nd group	Parameter protection code
0	0	Visible but NO MODIFICATION
1	1	NOT VISIBLE

Note: factory set parameters

CONFIGURATION CODE

Input type, scale range (1)	E	F	G	H	Type of action and safety Y1(3)	H
RTD Pt100 IEC 751	-200...600°C	1	1	1	Reverse Safety 0%	1
Thermocouple J Fe-Cu 45%Ni IEC 584	-99.9...300.0°C	1	1	1	Direct Safety 100% (Yh)	2
Thermocouple L Fe-Const DIN 43710	Conf. within 0...600°C	1	2	1	Reverse Safety -100% (Yh2) *	4
Thermocouple K Chromel-Alumel IEC 584	Conf. 0...600°C	2	1	1	Direct Safety -100% (Yh2) *	5
Thermocouple S Pt100%RhPt IEC 584	Conf. 0...1600°C	5	1	1	Reverse Safety Conf (4)	5
Thermocouple R Pt13%RhPt IEC 584	Conf. 0...1600°C	5	2	1	Direct Safety Conf (4)	7
4...20 mA	Conf. eng. units	7	4	1	Reverse Safety Off	8
0...20 mA	Conf. eng. units	7	5	1	Direct Safety Off	9
0...1 Vdc	Conf. eng. units	7	5	1		
0...10 Vdc	Conf. eng. units	7	7	1		
4...20 mA	Conf. eng. units with v	8	4	1		
0...20 mA	Conf. eng. units with v	8	5	1		
0...1 Vdc	Conf. eng. units with v	8	5	1		
0...10 Vdc	Conf. eng. units with v	8	7	1		

Type of Set point and control mode output Y2	I	L	M	N	Type of Set point	M
Disabled	0	0	0	0	1 Local	1
Deviation with startup inhibition	Active high	1	1	1	1 Local and Remote 4...20 mA	1
Band	Active low	2	2	2	1 Local and Remote 0...10 Vdc	2
Independent	Active outside	3	3	3	1 Local + 4 stored	3
Deviation	Active inside	4	4	4		
Independent	Active high	5	5	5		
Deviation	Active low	6	6	6		
Loop - Break - Alarm	Active high	7	7	7		
	Active low	8	8	8		
	Active low	9	9	9		

Retransmission output Y4	M
None (5)	0
Retransmission measurement	X
Retransmission Set point W	2
Retransmission Y1 Cool	3
Retransmission measurement	X
Retransmission Set point W	5
Retransmission Y1 Cool	6

PARAMETERS DESCRIPTION

Entering parameters

Once the configuration phase is completed, the controller will display all the parameters of functions that may be entered to their desired values. To simplify the exercise the parameters have been divided into two groups plus one. In the first group are listed all the parameters related to the set point of the instrument, in the second are inserted the PID control parameters and in the third group, which is protected by the password 1111, are inserted the access and/or operation indexes, the fuzzy control parameters, the parameters for the serial communication, all the limiting functions and safety states functions.

First group of parameters

SP.1 Stored set point 1 (N = 3)
SP.2 Stored set point 2 (N = 3)
SP.3 Stored set point 3 (N = 3)
SP.4 Stored set point 4 (N = 3)
 The memorised set points are the preset values for operation, recalled through logic inputs, serial transfer or the front keyboard. When one of these set values is recalled the small auxiliary display on the front of the instrument shows the set number recalled.

SL.1 Rate of variation in increase of the main set point SP.

Any new value of the main set point SP greater than that previously entered from the front keyboard, by linear transfer or recalled through logic or remote analogue inputs, will be associated with the rate established for that parameter. On switching on the controller put **W = X** and it will settle on the target set (the previously entered SP) at the established rate. The slope is expressed in digits/minute.

SL.2 Rate of variation in decrease of the main set point SP.

Any new value of the main set point SP greater than that previously entered from the front keyboard, by linear transfer or recalled through logic or remote analogue inputs, will be associated with the rate established for that parameter. On switching on the controller put **W = X** and it will settle on the target set (the previously entered SP) at the established rate. The slope is expressed in digits/minute.

SP.5P Set point of output Y2 (I = 1...8)

SP.5H Hysteresis of output Y2 (I = 1...8)

By hysteresis is meant a zone within which an output does not undergo changes and maintains the state previously assumed. In order to obtain a change in the state of variable X it is necessary to go outside this zone. The amplitude of this hysteresis zone is expressed as an amplitude % of the configured scale.

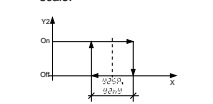

SP.5P Set point of output Y3 (L = 1...8)
 See **SP.5P**

SP.5H Hysteresis of output Y3 (L = 1...8)
 See **SP.5H**

Second group of parameters

HY Hysteresis of relay output Y1 (G = 0)

By hysteresis is meant a zone within which an output does not undergo go changes and maintains the state previously assumed. In order to obtain a change in the state of variable X it is necessary to go outside this zone. The amplitude of this hysteresis zone is expressed as an amplitude % of the configured scale. The output contacts are to be found between terminals 16 and 17.

Ph Proportional band (G = 1...9)
 The band within which commences the modulation of the output in direct proportion to the difference between the set point W and the variable X. It is calculated as a % of the scale amplitude and spread in a symmetrical mode with respect to the set point.

t.i Integral time (G = 1...9)
 This is the time used by a single integral action to repeat the contribution supplied by the proportional action. This action is expressed in minutes.

t.d Derivative time (G = 1...9)
 This is the time taken for a single proportional action to attain the same level as the P + D output. This action is expressed in minutes.

F.m Percentage intensity of fuzzy action (G = 1...9).
 The main control output is composed of the sum of two control algorithms, Fuzzy and PID. This parameter permits the balancing as a % of the proportion of the fuzzy algorithm in relation to that of the PID.

t.c Cycle time of the output Y1 (G = 1,2,6,7)
 This parameter is expressed in seconds and defines the total time of the On/Off states of the main output Y1 modulated in % of the PID + Fuzzy algorithm. e.g. if Y1 = 20% and t.c = 30", the On state = 6" and that of the Off = 24".

If G = 1 or 6, the output terminals 16 and 17.
 If G = 2 or 7, the logic output as a voltage is available between the terminals 19(a) and 20(c).

t.c.2 Cycle time for "cold output" Y1 (G = 6..9 and M = \leftrightarrow 3, \leftrightarrow 6).
 This parameter is expressed in seconds and defines the total time of the On/Off states of the cold output Y1 modulated in % of algorithm PID + Fuzzy. e.g. if Y = 20% and t.c2 = 30", the On state = 6" and that of the Off = 24".

The output relay contacts are between the terminals 17 and 18.

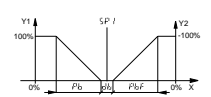

db The dead zone between the hot and cold outputs (G = 6..9)
 If the variable X coincides with the set point SP.1 and the output positions itself at 0% the

system will tend to pass continually between hot and cold and vice versa. The parameter involved defines that the command at the output of the controller, whether it is hot or cold, will only be forwarded if it is greater than that written in the same parameter.

c.c.r Relative gain of the "cold" output (G = 6..9).

This is a parameter that determines the amplitude of the proportional band of the cold with respect to that of the hot: $PbF = Pb \cdot c.c.r$
PbF = Proportional band output Y1 "cold"
Pb = Proportional band output Y1 "hot"

t.y Total rotation time for servomotor (G = 5)

This is the time used (expressed in seconds) for valve servomotors to travel from its lower run limit to its upper run limit. As a control algorithm of the "floating" type, this parameter is fundamental to a correct positioning of the valve servomotor.

d.y Resolution of positioning or dead zone (G = 5).

This parameter expressed in actuator run %, defines the minimum movement required for the servomotor. All the commands given by the control algorithm with lower amplitudes than the value written in the dy parameter, will not be executed.

P.a.t. Input procedure for calibration of servomotor position (G=5)

This parameter is added if the A/M button is pressed to enter into the calibration phase and the controller automatically locks on the servomotor. When on the X display the numbers stop it signifies that the servomotor has reached its lower run limit. Pressing the A/M button again, the controller stores the "0%" position and drives the servomotor to its maximum opening. When on the X display the numbers stop it signifies that the servomotor has reached its upper limit. Pressing the A/M button again, the controller stores the "100%" position. At this point the calibration operation is concluded and to terminate it is necessary to press the ">" enter button. During the calibration phase it is useful to time with a stopwatch the rotation for later insertion in the ty parameter.

Third group of parameters

RP.3: Access password to parameter groups

This function permits the concealment, viewing, but not modifying or rendering completely accessible groups of parameters. The first digit on the right of the display corresponds to the second group, the second digit from the right corresponds to the first group of parameters. The significance of the numbers to be inserted is as follows:

- 0 Group not visible
- 1 Group visible, without any facility to modify parameter

contents.
 - 2 Group visible, with facility to modify parameter contents.

RL.1 The purpose of this parameter is that of setting/tuning the automatic searching of PID and Fuzzy parameters. On entering "0" the tuning function is disabled and the "tune" parameter is no longer available in the main menu.

F.P.R. Span of fuzzy operational zone (G = 1..9)

The parameter in question permits the definition of the zone of operation for the fuzzy algorithm and is calculated in % of scale. The optimum value of this zone can be calculated using the following formula: $F.P.R. = 4 \times P.b$

F.d.P. Fuzzy derivative (G = 1..9).

This parameter permits "informing" the fuzzy algorithm of the speed of the process to be controlled. It is expressed as "% scale/minute" and its optimum value can be calculated with the formula: $F.d.P. = 4 \times P.b \cdot t.i$
Pb = Proportional band expressed as a percentage
t.i = Integral time expressed in minutes.

t.S.a.m Sampling time (G = 1..9)

This parameter determines the sampling time and is variable between 1 and 30 seconds max. The optimum sampling time is relative to the speed of the process to be controlled and is given by:

$t.S.a.m = t.i \times 60 / F.P.R.$

Pb = Proportional band expressed in % of scale

t.i = Integral time expressed in minutes.

SL.1 Fixing of parameter levels by linear transfer (B = 1)

Ad.d.r Recognition address of serial communication (B = 1)

SL.br Rate of serial communication (B = 1)

SL.P.3 Parity control of serial communication (B = 1)

These four parameters are related to serial communication, they only appear during the setting up phase of the instrument (B = 1) and do not relate to the configuration.

SP.L Limit of lower excursion of main set point SP1

SP.L.h Limit of upper excursion of main set point SP1

Example of entering set point limits

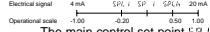

The main control set point SP.1 may only be freely entered between the two parameters **SP.L** and **SP.L.h**. Trying to input an "external" set point beyond the limit values, will be taken to be the entering of the relative limit.

SP.1 Sum of Local + Remote Set Points (N = 1,2)

This function permits the adding together of the remote analogue set point and the value of the local set point.

- 0 Set point target = remote set point

- 1 Set point target = remote set point + local set point

SP.R Gain control on remote analogue set point (N = 1,2)

This parameter determines the

excursion limits of the remote set point.

The inputable values are compressed between -100 and 100. Entering a value compressed between 1 and 100, if there is a direct action augments the analogue signal and augments the remote set point.

Entering a value compressed between -1 and -100, if there is an inverse action, augments the analogue signal and diminishes the remote set point. Entering "0" will not result in any variation of the remote set point and will coincide with the written value in parameter **SP.3**. In order to calculate the excursion amplitude of the remote set point the following formula may be used:

$SP.R = RL \times X \cdot SP.R.2 / 100$

SP.R.2 = Amplitude of remote set point

RL = Scale amplitude expressed in operational units

SP.R.2 = Number inserted in parameter

In order to better understand the functioning of these linearisation parameters refer to the two examples in the following drawings.

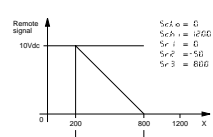
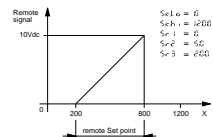

SP.R.3 Controlling zero on analogue remote set point (N = 1,2)

With this parameter it is possible to establish the starting point for the remote set point with the minimum remote input signal (0Vdc or 4mA). The inputable limit values correspond to the extreme values of the configured scale, **SL.L** and **SL.h**.

YL The minimum value that may be assumed at Y1 (G = 1..4)

Normally the control output is free to move between 0% and 100%. With this parameter in use it is possible to limit the required minimum value by which the control output will be free to move to that between the written value in the parameter YL and that written in the parameter YH. In the event of variable X going outside the scale limits, the value written in the parameter will not be respected and the output will assume the defined value of the safety state of Y1. (Configuration position H)

YL.2 The maximum value that may be assumed at Y1 (G = 1..9)

Normally the control output is free to move between 0% and 100%. With this parameter in use it is possible to limit the required maximum value by which the control output will be free to move between 0% and the value written in the parameter YH. In the event of variable X going outside the scale limits, the value written in the parameter will not be respected and the output will assume the defined value of the safety state of Y1. (Configuration position H)

YL.2 The maximum value that may be assumed at Y1 (G = 1..9)

Normally the control output is

free to move between 0% and 100%. With this parameter in use it is possible to limit the required maximum value by which the control output will be free to move between YL and the value written in the parameter YH. In the event of variable X going outside the scale limits, the value written in the parameter will not be respected and the output will assume the defined value of the safety state of Y1. (Configuration position H)

The maximum value that may be assumed at Y2 (G = 6..9). Normally the control output is free to move between 0% and 100%. With this parameter in use it is possible to limit the required maximum value by which the control output will be free to move between 0% and the value written in the parameter YH. In the event of variable X going outside the scale limits, the value written in the parameter will not be respected and the output will assume the defined value of the safety state of Y1. (Configuration position H)

t.F.t. Time constant of the agent digital filter on variable X.

This parameter defines the time constant of the digital filter positioned on the input variable X. Given an instantaneous variation between 0% and 100%, variable X will reach 63.2% in the time indicated in the parameter **t.F.t.**

The effect of the time constant t.F.t. on the input signal X

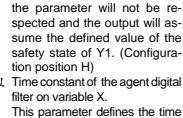

100%
63.2%
0
t.F.t.

X

0

t.F.t.

X

0

t.F.t.

X

0

t.F.t.

X

0

t.F.t.

X

0

t.F.t.

X

0

t.F.t.

X

0

t.F.t.

X

0

t.F.t.

X

0