

Temperature controllers series K
96 x 96 mm facia to DIN 43700
with 1, 2 or 3 intervention points
for connection to thermocouples
or resistance thermometers

Bulletin S 28-78/E

- Easy servicing plug-in chassis
- Dust and splashproof facia against hard working conditions
- 200 mm length ribbon scale for accurate temperature setting
- Indication: Surveillance type or Actual type indicator made up with a luminous bar moving behind the ribbon scale
- Adjustment of control parameters located under front panel door
- Control mode: On/Off, PD or PID with overshoot inhibition for straightline control
- Main output mode: Relay, Logic voltage, Zero-crossing or Phase angle pulses, DC voltage or current
- Optionals: High and low trip points

The wide variety of options and the good reliability and performances of these controllers provided by completely solid state construction and severe quality control meet the requirements of machines and small industrial plants.

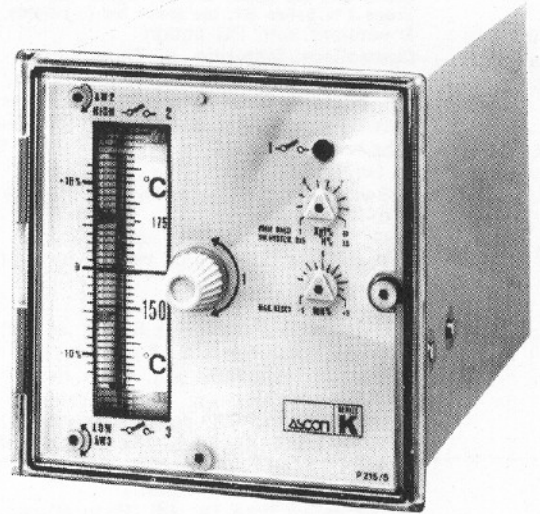

Models

Table n. 1

Options	Series	Input type	Intervention point number	Main control mode	Main output mode	Indication type	Scale Range (3)	Scale Code
Controller	K	TC TR	1 2L 2H 2P 3	P I	R L Z F C	S R	0... 250 °C Fe-Const 0... 400 °C Fe-Const 0... 600 °C Fe-Const 0... 800 °C NiCr-Ni 0...1200 °C NiCr-Ni 0...1500 °C Pt10% Rh-Pt	F1 F2 F3 K1 K2 S1
1 Main intervention point 1 Main + 1 « Low On/Off » limit trip 1 Main + 1 « High On/Off » limit trip 1 Main + 1 « High PD » limit trip 1 Main + 1 « Low On/Off » limit trip + 1 « High On/Off » limit trip								
PD action (1) PIDD action								
Relay Logic voltage (0/24 V dc) Zero crossing pulses Phase angle pulses D.C. (mA or Volt) (2)							-100... +50 °C Pt100 -50... +50 °C Pt100 10... 60 °C Pt100 0... 120 °C Pt100 0... 300 °C Pt100 0... 500 °C Pt100	P1 P2 P5 P6 P7 P8
Surveillance Actual value								

Notes: (1) Controllers, featuring a time-proportioning output (R, L, Z options), can be changed in On/Off controllers inserting a jumper between two terminals of the rear terminal board which eliminates the PD feedback.
 (2) See table 2.
 (3) Current (mA) and voltage (mV) inputs are available on request.

Example of order:

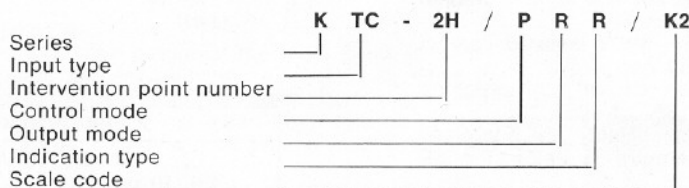

Series K controller, for thermocouple input, featuring 2 switching points (1 main intervention point + 1 High On/Off trip), with PD behaviour and relay output, with actual indicator, scale 0...1200 °C NiCr-Ni.

SPECIFICATIONS:

Inputs: **TC version:** for Thermocouples, J (I/C), K (C/A), S (Pt10% Rh/Pt) according to German Standard DIN 43710

Main Set-point W1: **TR version:** for Platinum Resistance thermometer 100 Ω @ 0°C according to German Standard DIN 43760
 - Accuracy: 1% of span
 - Ribbon scale length: 200 mm
 Note: Front set-knob withdrawable from seat in order to avoid undesired set point changes

Indication: **S version:** Surveillance type
 Surveilled band: ± 2% around SP
 If the temperature process rises by 2% above SP, the upper led (+) lights and if it drops 2% below SP, the lower led (-) lights.
P version: with PD action

Main point control action: **Controllers featuring a Time proportionating action can be changed in On/Off controllers by inserting a jumper between terminals 11 and 13 on the rear terminal board**

1. On/Off mode
 - Switching hysteresis **H₁**: adj. 0,15% to 1,5% of span
2. PD mode
 - Prop. band **Xp₁**: adj. 1% to 10% of span
 - Derivative time **Tv**: 35 sec.
 - Cycling time **Tc**: 25 ± 5 sec. at half power (only for R, L, Z outputs)
 - Manual reset **MR₁**: adj. -3% to +3% of span

- I version:** with PIDD action (see note 1)
- Prop. band **Xp₁**: adj. 1% to 10% of span
 - Integral time **Tn**: 4 min.
 - Derivative time **Tv**: adj. 10 to 40 sec. with internal trimmer
 - Cycling time **Tc**: 25 ± 5 sec. at half power (only for R, L, Z outputs)

Output mode of main point: **R version:** Relay type
 - SPDT isolated contact rated 5 A/250 V ac
 - protected by a plug-in fuse
L version: Logic voltage type (e.g. useful for driving a remote static relay or contactor). Output is not isolated from control circuit.
 - Logic signal: 24 dc ± 20%; 25 mA max.

Z version: Zero crossing pulses type
 Pulses suitable for switching inverse parallel pair thyristors in the supply synchronised zero voltage mode.
 - Pulses: 6 V, 0,5 A, 100 μsec, 2500 V ac isolation

F version: Phase angle pulses type
 Pulses suitable for switching inverse parallel pair thyristors in the phase angle mode.
 - Pulses: 6 V, 0,5 A, 100 μsec, 2500 V ac isolation

Note: Supply voltage of controller and of power load should be in phase.

C version: DC current or voltage type
 - Output range: see table 2
 - Action mode: reverse action (D.C. output decreases when temperature increases)

Limit trips (see note 2):

2L version: Low On/Off limit trip
 - Setting **ΔW2**: adj. 0% to 12% of span below the main SP
 - Output mode: SPDT isolated contact rated 5 A/250 V ac
 - Control mode: On/Off with switching hysteresis 0,5% of span
 - Action mode: Relay is energized when temperature is below the SP limit

2H version: High On/Off limit trip
 - Setting **ΔW2**: adj. 0% to 12% of span above the main SP
 - Output mode: SPDT isolated contact rated 5 A/250 V ac
 - Control mode: On/Off with switching hysteresis of 0,5% of span

- Action mode: Relay is energized when temperature is above the SP limit

2P version: High PD limit trip
 Useful for proportioning control of the cooling flow for heat-cool applications. Characteristics are same as for 2H version but with:

- Control mode: On/Off with PD behaviour
- Prop. band **Xp₂**: adj. 1% to 10% of span with internal trimmer

3 version: High and Low On/Off limit trip
 Characteristics like those of 2H and 2L but with:

- Output mode: 1 SPST contact for each trip

Main set-point drift: **TC version:** for Thermocouple
 ≤ 1°C/10°C ambient temp. variation for J and K couples
 ≤ 1°C/5°C ambient temp. variation for S couple
 ≤ 0,1%/10% supply voltage variation
 ≤ 1°C/40 Ω lead connection variation for J and K couples
 ≤ 1°C/10 Ω lead connection variation for S couple

TR version: for Resistance thermometer
 ≤ 0,1°C/10°C ambient temp. variation
 ≤ 0,1%/10% supply voltage variation
 ≤ 1°C/10 Ω lead resistance in the «3-wire» mode connection
 Not above 150 Ω for T/C and 10 Ω for R/T in the «3-wire» mode connection
 Upscale standard

Sensor lead resistance:

Thermocouple break:

Thermocouple cold junction:

Protection:

Isolation group:

Climatic group:

Ambient temp.:

Supply:

Weight:

Automatically compensated

According to DIN 40050

- case: IP30

- terminals: IP10

- facia: IP53

C to VDE 0110

KVF to DIN 40040

0°C to 55°C max.

110 V/220 V +10% -15%; 48...63 Hz; 4 VA max. 24 V on request

Approx. 0,8 kg

Note 1: The PIDD action. The PIDD control mode combines the advantages of both PD and PID actions and avoids their respective inconveniences. At start-up the PIDD controller behaves like the PD one (with contained overshoot or without overshoot), while during working conditions it behaves like the PID controller (permanent deviation from SP. is eliminated for any load condition). Moreover, the PIDD controller particularly suit the industrial thermic processes because there is no need, as for the PID controller, to optimize all the P, I and D parameters for obtaining accurate regulations, but only the P and sometimes the D parameters.

Note 2: Output modes and signalings.

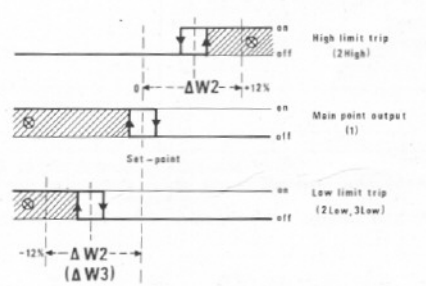

Ranges of DC voltage or current output

Output Range	Range Code
0... 5 mA DC 15 V max	C1
0...10 mA DC 15 V max	C2
0...20 mA DC 15 V max	C3
1... 5 mA DC 15 V max	C4
4...20 mA DC 15 V max	C5
0... 5 V DC 20 mA max	C8
0...10 V DC 20 mA max	C9

Table n. 2

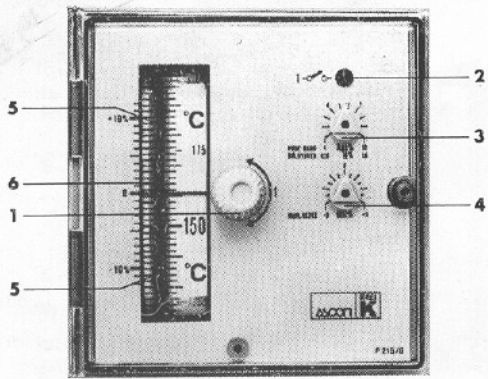

1 Main intervention point controller

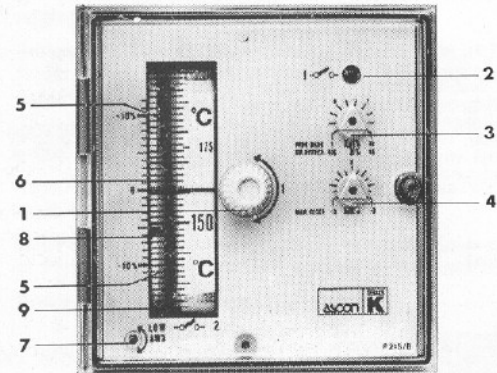
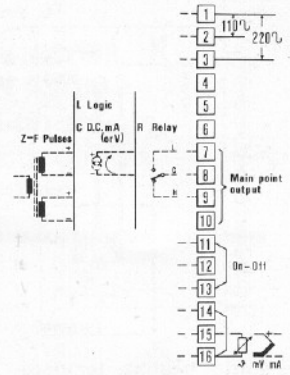

1 Main intervention point +
1 Low limit trip controller

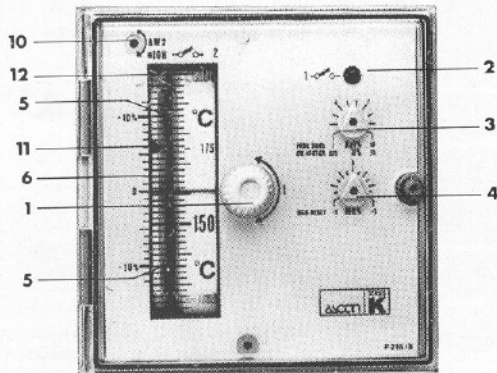
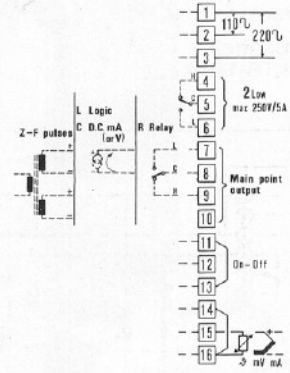

1 Main intervention point +
1 High limit trip controller

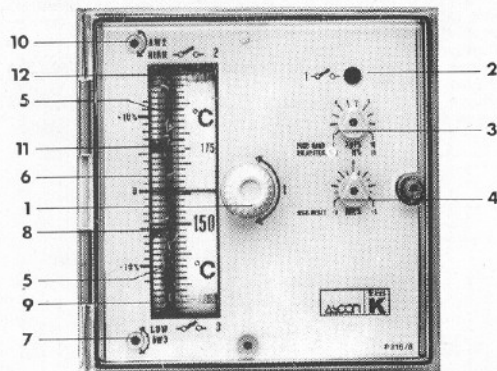
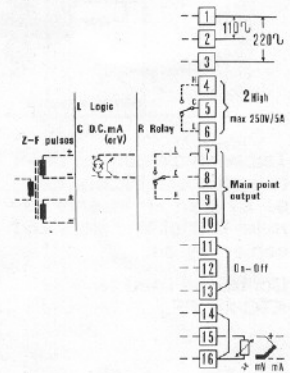

1 Main point +
1 Low limit trip +
1 High limit trip controller

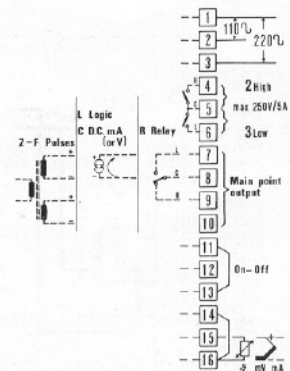

- 1 - Setting of the main set point W_1 .
- 2 - Red signal lamp: it lights when the output of the main point is « On ».
- 3 - Proportional band adjustment Xp_1 (or switching hysteresis H_1 when the On/Off without feedback output mode is selected).
- 4 - Manual Reset adjustment **MR** (it is missing for controllers with I control mode).
- 5 - Surveillance indicator made up with 2 red leds. They light when the controlled temperature is outside the surveilled band.
- 6 - Actual temperature indicator made up with 16 leds placed behind the ribbon scale.
- 7 - Setting of the Low limit trip.
- 8 - Red index indicating the set value of the Low limit trip.
- 9 - Red signal lamp: it lights when the relay of the Low limit trip is energized.
- 10 - Setting of the High limit trip.
- 11 - Red index indicating the set value of the High limit trip.
- 12 - Red signal lamp: it lights when the relay of the High limit trip is energized.

Note: All settings and adjustments can be carried out using the front set-knob after the transparent door has been opened.

Some Applications

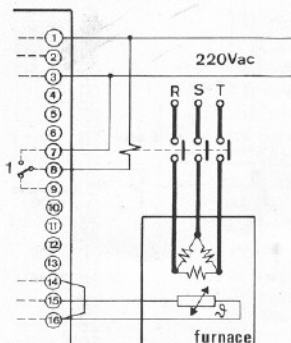

Electric heating temperature control with a contactor.

Controller used:
KTR-1/PR./..

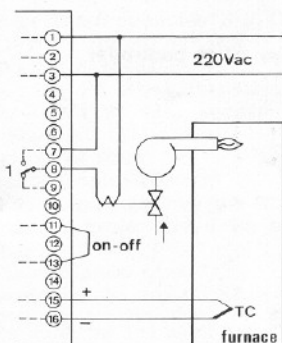

Temperature control with of a gas-fired burner.

Controller used:
KTC-1/PR./..

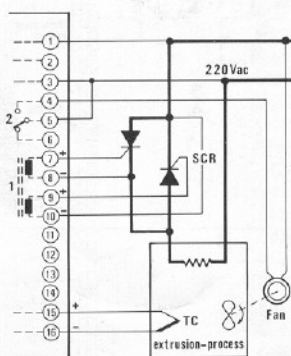

Temperature control of an extruder electrically heated by with an inverse parallel pair of thyristors and cooled by air.

Controller used:
KTC-2P/PF./..

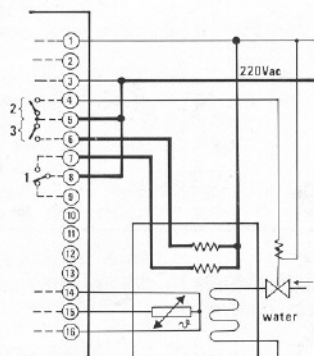

Temperature control of a process heated by 2 groups of electric resistances and cooled by water.

Note: the connection of the T/R is in the 3-wire mode.

Controller used:
KTR-3/PR./..

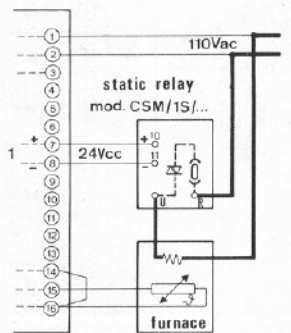

Electric heating temperature control with a static relay.

Controller used:
KTR-1/IL./..

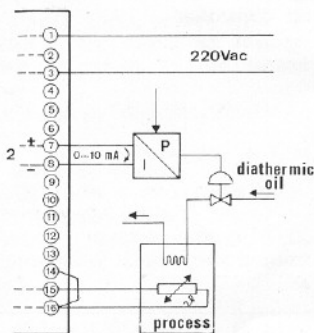

Temperature control of a diathermic oil heated process. A pneumatic valve driven by an electro-pneumatic converter modulates the heating flow.

Controller used:
KTR-1/IC2./..

Partially withdrawn plug-in chassis

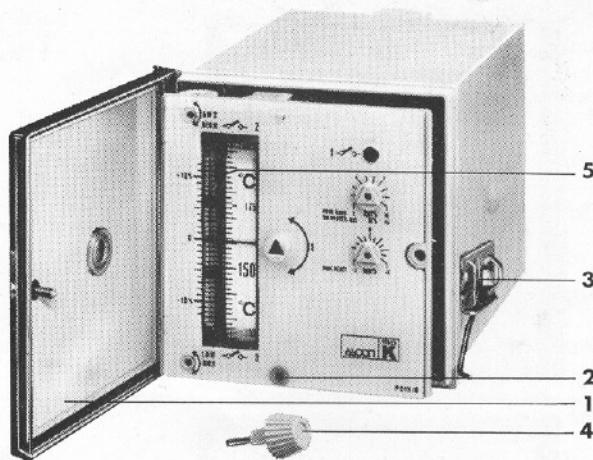

- 1) Transparent dust and splashproof door (IP53)
- 2) Screw for plugging chassis into the panel casing
- 3) Panel fixing clamp
- 4) Multiuse knob for temperature setting, door opening, plug-in chassis withdrawn, control parameter adjustments.
- 5) Luminous indicator

Terminal board

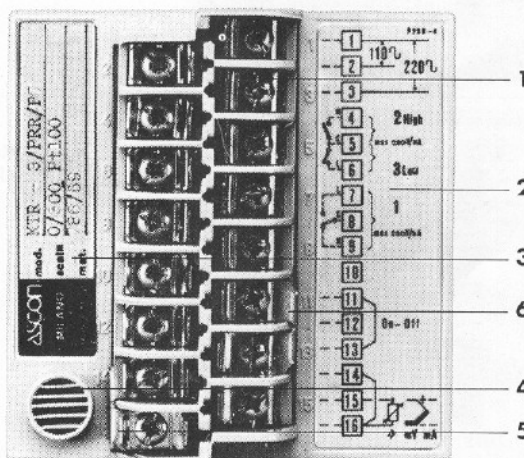

- 1) Terminal: For screw and/or 6,35 mm faston connection
- 2) Wiring scheme label
- 3) Identification model label
- 4) Place of compensator of cold thermocouple junction
- 5) Jumper: Remove for 3-wire mode connection of the Resistance thermometer (not used for T/C)
- 6) Jumper: Remove for time-proportioning mode of the main point output (not used for PIDD controller)

Dimensions

